

90% Remedial Design Basis of Design Report

Appendix E

Biological Assessment

Lower Duwamish Waterway Group

Port of Seattle / City of Seattle / King County / The Boeing Company

BIOLOGICAL ASSESSMENT FOR LOWER DUWAMISH WATERWAY UPPER REACH REMEDIAL DESIGN

For submittal to

U.S. Environmental Protection Agency

Seattle, WA

July 25, 2023

Prepared by:



1201 3rd Avenue • Suite 2600
Seattle, Washington • 98101

in association
with



200 West Mercer Street • Suite 401
Seattle, Washington • 981199

TABLE OF CONTENTS

1	Introduction	1
1.1	Background.....	1
1.2	Need for the Proposed Action.....	2
1.3	Federal Nexus.....	2
1.4	Organization of the Document.....	2
2	Description of the Proposed Action.....	4
2.1	Project Location.....	4
2.2	Project Elements and Construction Methods.....	4
2.2.1	Dredging.....	9
2.2.2	Transport, Transloading, and Disposal of Dredged Material	13
2.2.3	Engineered Capping.....	14
2.2.4	Placement of Backfill, RMC, Enhanced Natural Recovery, and Amended Cover Materials	16
2.2.5	Monitored Natural Recovery.....	19
2.2.6	In-Water Structure Modifications	20
2.2.7	Construction Access	21
2.2.8	Summary of Remedial Activities.....	22
2.3	Project Timing.....	25
2.4	Impact Avoidance, Minimization, and Conservation Measures	25
2.4.1	General	25
2.4.2	Dredging.....	26
2.4.3	Barge Loading and Dewatering	28
2.4.4	Transport and Transloading of Dredged Material.....	28
2.4.5	Placement of Engineered Cap, Backfill, RMC, ENR, and Amended Cover Materials	29
2.4.6	Pile Installation	31
2.4.7	Pile Removal	31
3	Action Area	33
3.1	Terrestrial Extent.....	33
3.2	Aquatic Extent.....	34
4	Environmental Baseline.....	36
4.1	Biological Habitat Conditions.....	37
4.1.1	Riparian Habitat and Large Woody Debris.....	37

4.1.2	In-Channel Habitat.....	39
4.2	Physical Conditions.....	41
4.2.1	Shoreline Armoring.....	41
4.2.2	Substrate and Slope	41
4.2.3	Overwater and In-Water Structures	42
4.3	Chemical Conditions	43
4.3.1	Water Quality	43
4.3.2	Sediment Quality	46
5	Species and Critical Habitats Potentially Present in Action Area	47
5.1	Chinook Salmon Puget Sound Evolutionarily Significant Unit	47
5.1.1	Critical Habitat Presence in the Action Area.....	48
5.1.2	Utilization of the Action Area	49
5.2	Steelhead Puget Sound Distinct Population Segment.....	50
5.2.1	Critical Habitat Presence in the Action Area.....	51
5.2.2	Utilization of the Action Area	52
5.3	Coastal-Puget Sound Bull Trout.....	52
5.3.1	Critical Habitat Presence in the Action Area.....	53
5.3.2	Utilization of the Action Area	54
5.4	Puget Sound/Georgia Basin Yelloweye Rockfish Distinct Population Segment.....	55
5.4.1	Critical Habitat Presence in the Action Area.....	55
5.4.2	Utilization of the Action Area	55
5.5	Puget Sound/Georgia Basin Bocaccio Distinct Population Segment.....	56
5.5.1	Critical Habitat Presence in the Action Area.....	56
5.5.2	Utilization of the Action Area	56
5.6	Southern Resident Killer Whale Distinct Population Segment.....	57
5.6.1	Critical Habitat Presence in the Action Area.....	58
5.6.2	Utilization of the Action Area	58
5.7	Sunflower Sea Star.....	58
5.7.1	Utilization of the Action Area	59
5.8	Marbled Murrelet.....	59
5.8.1	Utilization of the Action Area	60
5.9	Western Yellow-Billed Cuckoo	60
5.10	North American Wolverine.....	60
6	Analysis of Direct and Delayed Effects.....	61
6.1	Effects to Species.....	62

6.1.1	Underwater Noise Effects.....	62
6.1.2	Entrainment	63
6.1.3	Water Quality	64
6.1.4	Resuspension of Contaminants	69
6.1.5	Changes to Prey Species.....	75
6.1.6	Modification of Habitat.....	76
6.2	Effects to Designated Critical Habitat.....	80
6.2.1	Puget Sound Chinook Salmon Evolutionarily Significant Unit Critical Habitat	80
6.2.2	Puget Sound Steelhead Distinct Population Segment Critical Habitat	83
6.2.3	Coastal-Puget Sound Bull Trout Distinct Population Segment Critical Habitat.....	86
7	Effects Determinations	88
7.1	Chinook Salmon Puget Sound ESU.....	88
7.1.1	Species Effects Determination.....	88
7.1.2	Critical Habitat Effects Determination	90
7.2	Steelhead Puget Sound DPS.....	90
7.2.1	Species Effects Determination.....	90
7.2.2	Critical Habitat Effects Determination	92
7.3	Coastal-Puget Sound Bull Trout.....	92
7.3.1	Species Effects Determination.....	92
7.3.2	Critical Habitat Effects Determination	93
7.4	Puget Sound/Georgia Basin Yelloweye Rockfish Distinct Population Segment.....	94
7.5	Puget Sound/Georgia Basin Bocaccio Distinct Population Segment.....	95
7.6	Southern Resident Killer Whale Distinct Population Segment.....	95
7.7	Sunflower Sea Star	96
7.8	Marbled Murrelet.....	97
8	Essential Fish Habitat Assessment.....	98
8.1	Essential Fish Habitat Background	98
8.2	Potential Effects of the Proposed Action	98
8.2.1	Pacific Salmon EFH Effects Determination.....	99
8.2.2	Groundfish EFH Effects Determination	99
9	References	100

TABLES

Table E1-1	Intermediate (60%) RD Technology Assignments by RAA	5
Table E2-1	Summary of Area of Impact for Dredging and Material Placement Activities	23
Table E2-2	Summary of Permanent In-Water Structure Installation and Removal	24
Table E4-1	Baseline Water Chemistry Data for the LDW and Upstream Area (Windward 2020)	44
Table E5-1	Puget Sound Chinook Salmon ESU Critical Habitat PBFs Within the Lower Duwamish Waterway	49
Table E5-2	Puget Sound Steelhead DPS Critical Habitat PBFs within the Lower Duwamish Waterway	51
Table E5-3	Bull Trout Critical Habitat PBFs Within the Lower Duwamish Waterway	53
Table E6-1	Summary of Listed Species and Designated Critical Habitat in the Action Area and Effects Determinations.....	61
Table E6-2	Summary of Water Quality Monitoring Results for Recent LDW Dredge Projects.....	71
Table E6-3	Semi-Quantitative Habitat Evaluation Results.....	79
Table E6-4	PSNC Habitat Evaluation Results.....	80
Table E6-5	Potential Proposed Action Effect on Chinook Salmon PBFs.....	81
Table E6-6	Potential Proposed Action Effect on Steelhead PBFs.....	84
Table E6-7	Potential Proposed Action Effect on Bull Trout PBFs	87

FIGURES

Figure E1-1	LDW Superfund Site Vicinity Map and Identification of Upper Reach
Figure E2-1	Remedial Action Areas Within the Upper Reach
Figure E2-2a	Existing Habitat Conditions and Remedial Action Areas Within the Upper Reach
Figure E2-2b	Existing Habitat Conditions and Remedial Action Areas Within the Upper Reach
Figure E2-3a	Proposed Remedial Activities by Remedial Action Area
Figure E2-3b	Proposed Remedial Activities by Remedial Action Area
Figure E3-1	Action Area
Figure E4-1a	Existing Habitat Conditions Within the Remedial Action Areas
Figure E4-1b	Existing Habitat Conditions Within the Remedial Action Areas
Figure E4-2	Shoreline Armoring and Overwater and In-Water Structures
Figure E6-1a	Post-Construction Habitat Conditions Within the Remedial Action Areas
Figure E6-1b	Post-Construction Habitat Conditions Within the Remedial Action Areas

EXHIBITS

Exhibit E2-1	Different Mechanical Dredge Bucket Types.....	12
Exhibit E2-2	In-Water Placement of Clean Material Using Typical Marine Equipment	19

ATTACHMENTS

Attachment E.1	Remedial Action Area Photographs
Attachment E.2	Summary of Remediation Components Table
Attachment E.3	NMFS Underwater Noise Calculator
Attachment E.4	Water Quality Effects Evaluation, Appendix K of the Intermediate (60%) Remedial Design Basis of Design Report
Attachment E.5	Vegetation Observations, Appendix I to the Final Pre-Design Investigation Data Evaluation Report
Attachment E.6	Habitat Evaluation
Attachment E.7	Summary of Effects Table

ABBREVIATIONS

AOC	Administrative Order on Consent
AOC4	fourth amendment to the AOC
ARAR	Applicable or Relevant and Appropriate Requirements
BA	<i>Biological Assessment</i>
BERA	Baseline Ecological Risk Assessment
BMP	best management practice
BODR	<i>Basis of Design Report</i>
Boeing	The Boeing Company
CERCLA	Comprehensive Environmental Response, Compensation, and Liability Act
CFR	Code of Federal Regulations
cm	centimeter
COC	contaminant of concern
COPC	contaminant of potential concern
cPAH	carcinogenic polycyclic aromatic hydrocarbon
CWA	Clean Water Act
cy	cubic yard
dB	decibel
dBA	A-weighted decibel
dB RMS	decibels in root-mean-square pressure
DPS	distinct population segment
DO	dissolved oxygen
DSAY	discounted-service-acre-year
Ecology	Washington State Department of Ecology
EFH	Essential Fish Habitat
ENR	enhanced natural recovery
EPA	U.S. Environmental Protection Agency
ESA	Endangered Species Act
ESD	explanation of significant differences
ESU	evolutionarily significant unit
FR	Federal Register
FNC	federal navigation channel
FS	Feasibility Study
H:V	horizontal to vertical
HEA	Habitat Equivalency Analysis
K _{ow}	partitioning coefficient
LDW	Lower Duwamish Waterway

LDW Superfund Site	Lower Duwamish Waterway Superfund Site
LDWG	Lower Duwamish Waterway Group
LAA	likely to adversely affect
LWD	large woody debris
Magnuson-Stevens Act	Magnuson-Stevens Fishery Conservation and Management Act
mg/L	milligrams per liter
MHHW	mean higher high water
MLLW	mean lower low water
MNR	monitored natural recovery
N/A	not applicable
NLAA	not likely to adversely affect
NMFS	National Marine Fisheries Service
NOAA	National Oceanic and Atmospheric Administration
NPDES	National Pollutant Discharge Elimination System
NTU	nephelometric turbidity unit
OHHW	ordinary high water mark
PAH	polycyclic aromatic hydrocarbon
PBF	physical or biological feature
PCB	polychlorinated biphenyl
PDI	pre-design investigation
PNNL	Pacific Northwest National Library
propwash	propeller wash
PSNC	Puget Sound Nearshore Calculator
RAA	remedial action area
RAL	remedial action level
RAWP	Remedial Action Work Plan
RD	remedial design
RHV	relative habitat value
RI	Remedial Investigation
RM	river mile
RMC	residuals management cover
ROD	<i>Record of Decision</i>
SEL	sound exposure level
Services	National Marine Fisheries Service and U.S. Fish and Wildlife Service
SSWS	sea star wasting syndrome
TSS	total suspended solids

U&A	Usual and Accustomed
USACE	U.S. Army Corps of Engineers
WAC	Washington Administrative Code
WDFW	Washington Department of Fish and Wildlife
WQMP	<i>Water Quality Monitoring Plan</i>
WRIA	Water Resource Inventory Area
USFWS	U.S. Fish and Wildlife Service

1 Introduction

The Lower Duwamish Waterway Group (LDWG), in coordination with the U.S. Environmental Protection Agency (EPA) and Washington State Department of Ecology (Ecology), is implementing a cleanup remedy for the upper reach of the Lower Duwamish Waterway (LDW) Comprehensive Environmental Response, Compensation, and Liability Act (CERCLA, or Superfund) Site in King County, Washington (EPA Site No. WA00002329803). The City of Seattle, King County, the Port of Seattle, and The Boeing Company (Boeing), agreed to an Administrative Order on Consent (AOC) to conduct remedial design (RD) for the upper reach under the fourth amendment to the AOC (AOC4) for the LDW, with oversight by EPA and Ecology.

The LDW Superfund Site extends 5 miles upstream from the southern tip of Harbor Island to just upstream of the Turning Basin at river mile (RM) 5, a federally authorized and maintained navigation feature consisting of an area where ship traffic can turn around. The LDW Superfund Site has been divided into three reaches (lower, middle, and upper), which are undergoing separate RDs on staggered time frames. The upper reach comprises the furthest upstream two RMs: 3.0 to 5.0 (Figure E1-1).

The project is proposed to clean up sediments that are a result of over a century of urbanization and industrial activity on the LDW consistent with the EPA *Record of Decision* (ROD; EPA 2014), the carcinogenic polycyclic aromatic hydrocarbon (cPAH) *Explanation of Significant Differences* (ESD) (EPA 2021), and AOC4 (EPA 2018). The remedial technologies selected for cleanup include a combination of dredging, enhanced natural recovery (ENR), engineered capping, and monitored natural recovery (MNR).

This *Biological Assessment* (BA) is prepared based on the 60% RD for the upper reach and is intended to demonstrate substantive compliance for this federal cleanup action under the Endangered Species Act (ESA) and the Magnuson-Stevens Fishery Conservation and Management Act (Magnuson-Stevens Act). Separate BAs will be prepared for subsequent cleanup phases (middle and lower reaches).

1.1 Background

In the early 1900s, the lower 6 miles of the Duwamish River were straightened and channelized into a commercial corridor for ship traffic, officially designated as the LDW and the East and West Waterways (located along the east and west shorelines of Harbor Island). The LDW has served as the City of Seattle's major industrial corridor since the early 1900s. This has caused the LDW sediments to be contaminated through various inputs, including discharges of waste, stormwater, and historical and ongoing commercial and industrial use.

In September 2001, the EPA formally added the LDW to the National Priorities List as a Superfund Site, and in February 2002, Ecology listed the LDW as a cleanup site under the Washington Model Toxics

Control Act site. The EPA ROD was issued in 2014 (EPA 2014). The ROD, and subsequent amendments, provides the EPA-selected remedy for the in-water portion of the Lower Duwamish Waterway Superfund Site (LDW Superfund Site). EPA and Ecology have divided lead agency responsibility for addressing the site: EPA is responsible for administering the cleanup of the sediments in the waterway, and Ecology is responsible for controlling sources of pollution to the waterway. EPA issued a ROD for the LDW in 2014. The selected remedy issued by EPA is consistent with CERCLA. The State of Washington, through Ecology, has reviewed and concurs with the selected remedy.

The primary contaminants exceeding remedial action levels (RALs) in the upper reach are polychlorinated biphenyls (PCBs). Other contaminants that determine the RAL cleanup areas include metals, polycyclic aromatic hydrocarbons (PAHs), other semivolatile organic compounds, butyl benzyl phthalate, benzoic acid, 4-methylphenol, and phenol), and dioxins/furans, depending on the area (Anchor QEA and Windward 2022).

1.2 Need for the Proposed Action

The proposed action (i.e., the remedial action for upper reach) is needed to address contamination at the LDW Superfund Site consistent with the remedial action defined in the ROD (EPA 2014) and ESD (EPA 2021). The remedy will address unacceptable human health risks associated with consumption of resident fish and shellfish and with direct contact (skin contact and incidental ingestion) from net fishing, clamming, and recreational beach uses. The project also addresses ecological risks to bottom-dwelling organisms (benthic invertebrates), fish, and wildlife. The selected remedy includes active remediation and natural recovery to achieve remedial action objectives. There will be long-term monitoring to assess the success of the remedy in achieving cleanup levels. Remedial action in the upper reach is the focus of this BA.

1.3 Federal Nexus

The proposed action, which is described in Section 2, is being implemented under CERCLA with EPA as the lead federal agency. The proposed action must comply with Applicable or Relevant and Appropriate Requirements (ARARs), including the ESA and the Magnuson-Stevens Act. As the federal lead agency, EPA is responsible for consulting with the National Marine Fisheries Service (NMFS) and U.S. Fish and Wildlife Service (collectively called the Services) on potential impacts the proposed action may have on ESA-listed species and critical habitats.

1.4 Organization of the Document

The remainder of this document includes the following sections:

- **Section 2** provides a description of the proposed action, construction methods, project timing, and impact avoidance, minimization, and conservation measures.

- **Section 3** describes the action area, which is the geographical extent of the effects of the action on the environment.
- **Section 4** provides information on the environmental baseline conditions within the action area.
- **Section 5** describes the listed species and critical habitats potentially present in the action area.
- **Section 6** presents an evaluation of the potential effects of the proposed action to listed species and critical habitats.
- **Section 7** describes the effects determinations for each listed species and critical habitat that may occur in the action area.
- **Section 8** provides an assessment of Essential Fish Habitat (EFH).
- **Section 9** provides references cited in the document.

2 Description of the Proposed Action

2.1 Project Location

The upper reach of the LDW extends from Duwamish Waterway Park (RM 3.0) to the southern end of the LDW at RM 5.0 near the bridge on South 102nd Street (Figure E1-1). The average width of the upper reach is 540 feet wide.

2.2 Project Elements and Construction Methods

This section describes the proposed action, including methods for construction and impact avoidance, minimization, and conservation measures that will be taken to minimize impacts to listed species. The proposed action consists of the overall remedial action for the selected remedy for the upper reach of the LDW, as set forth in the ROD, fourth amendment to the AOC, and ESD (EPA 2014, 2018, 2021).

The Preliminary (30%) RD for the upper reach identified areas of sediment that exceeded ROD-defined RALs. The RAL exceedance areas were further developed into remedial action areas (RAAs) that have a larger footprint and encompass the RAL exceedance areas to account for engineering and constructability considerations, which provides a greater degree of confidence for removing sediment that exceeds the RALs. After the Preliminary (30%) RD submittal to EPA, Intermediate (60%) RD was completed and addressed comments received from EPA on the Preliminary (30%) RD. This BA uses the RAAs that were updated during Intermediate (60%) RD; the updated Intermediate (60%) RD *Basis of Design Report* (BODR) was submitted to EPA on February 20, 2023 (Anchor QEA and Windward 2023). Concurrent with Intermediate (60%) RD, additional Phase III pre-design investigation (PDI) data was collected in the upper reach and will be incorporated into the Pre-Final (90%) RD. Because the new Phase III PDI data may result in some revisions to RAA boundaries, the BA has included allowances (RAA surface area and volume contingencies in addition to the Intermediate [60%] RD) to assess the maximum anticipated impacted areas and volumes.

Remedial activities will be completed within the RAAs and include dredging; debris removal; engineered capping; clean material placement for backfill for habitat area restoration, residuals management cover (RMC), and ENR; and overwater/in-water structure modification. Dredged sediment and debris materials will also require in-water transport by barge to a transloading facility, barge offloading, upland transport by rail or trucks, and disposal of dredged material and debris at a permitted commercial landfill. Clean material used for placement will also require barge transport to the upper reach. MNR is included as part of the remedy and requires monitoring rather than active remediation.

Figure E2-1 shows the locations of the RAAs, and Figures E2-2a and E2-2b show the RAAs relative to existing habitat conditions. Attachment E.1 includes photographs of the intertidal area and/or bank area for the RAAs that are close to the shoreline. Table E1-1 outlines the remedial activities that will be completed within each RAA, which are shown in Figures E2-3a and E2-3b. The table in Attachment E.2 provides a summary of the proposed action elements, their locations, potential exposure details (stressor, timing, duration, frequency, species information, and potential responses to stressor), and avoidance and minimization measures. Additional details about the types of remedial and construction activities are included in the following subsections.

**Table E1-1
Intermediate (60%) RD Technology Assignments by RAA**

Remedial Action Area ¹	Area (acreage)	Intermediate 60% RD Technology Assignment ^{2,3}	Notes	Approximate Existing Elevation Range (feet MLLW)	Required Dredge Depth/Elevation Range ^{4,5}
1/2/3	2.42	Dredge and Backfill	Elevations shallower than -10 MLLW will be backfilled to grade.	-4 to -17	-20 to -22 feet MLLW
		Dredge	Elevations deeper than -10 MLLW will not be backfilled to grade, but RMC material will be placed.		
4/5	4.24	Dredge and Backfill	Elevations shallower than -10 MLLW and outside the FNC will be backfilled to grade.	-5 to -22	-18 to -22 feet MLLW; 2-foot thickness cut at south end (to -24-foot MLLW)
		Dredge	Areas within the FNC or elevations deeper than -10 MLLW will not be backfilled to grade, but RMC material will be placed.		
6	0.03	Dredge	Elevations deeper than -10 MLLW will not be backfilled to grade, but RMC material will be placed.	-9 to -15	2-foot cut (-11 to -17 feet MLLW)
7	0.03	ENR	ENR material to be placed on existing mudline.	-1 to -7	N/A
8	0.03	Dredge and Backfill	Elevations shallower than -10 MLLW will be backfilled to grade.	-1 to -5	1-foot cut (-2 to -6 feet MLLW)

Remedial Action Area ¹	Area (acreage)	Intermediate 60% RD Technology Assignment ^{2,3}	Notes	Approximate Existing Elevation Range (feet MLLW)	Required Dredge Depth/Elevation Range ^{4,5}
10	0.04	ENR	ENR material to be placed on existing mudline.	4 to -4	N/A
11	0.10	Dredge and Backfill	Elevations shallower than -10 MLLW and outside the FNC will be backfilled to grade.	-6 to -16	-17.5 feet MLLW
12	0.03	Dredge	Areas within the FNC or elevations deeper than -10 MLLW will not be backfilled to grade, but RMC material will be placed.	-9 to -15	1-foot cut (-10 to -16 feet MLLW)
13	0.07	Dredge	Areas within the South Park Marina will not be backfilled to grade, but RMC material will be placed.	-1 to -3	-9 feet MLLW
	0.09	ENR	ENR material will be placed over existing riprap slope.	10 to -2	N/A
14/15/16 ⁶	1.2	Dredge and Backfill	Elevations shallower than -10 MLLW will be backfilled to grade.	-2 to -16	-23 feet MLLW
		Partial Dredge and Engineered Cap	Areas within the FNC will be treated with an engineered cap.		
17	0.11	Dredge	Areas within the FNC or elevations deeper than -10 MLLW will not be backfilled to grade, but RMC material will be placed.	-11 to -14	1-foot cut (-12 to -15 feet MLLW)
18 (South)	0.54	Dredge and Backfill	Elevations shallower than -10 MLLW will be backfilled to grade.	5 to -11	2.5 to 3.5-foot cut (2 to -12 feet MLLW)
	0.02	Area-Specific Technology B: Amended Cover	Amended cover material will be placed on existing mudline in structural offset areas.	5 to 4	N/A
	0.009	Slag Pile Removal	Slag pile will be removed.	2 to 0	2-foot cut (0 to -2 feet MLLW)

Remedial Action Area ¹	Area (acreage)	Intermediate 60% RD Technology Assignment ^{2,3}	Notes	Approximate Existing Elevation Range (feet MLLW)	Required Dredge Depth/Elevation Range ^{4,5}
19/20	0.16	Dredge and Backfill	Elevations shallower than -10 MLLW will be backfilled to grade.	10 to -5	1.5 to 3.5-foot cut (-6 to 8 feet MLLW)
21	0.07	Dredge and Backfill	Elevations shallower than -10 MLLW will be backfilled to grade.	-3 to -12	2-foot cut (-5 to -14 feet MLLW)
22	0.62	Dredge and Backfill	Elevations shallower than -10 MLLW will be backfilled to grade.	8 to -12	2-foot cut (6 to -14 feet MLLW)
		Dredge	Elevations deeper than -10 MLLW will not be backfilled to grade, but RMC material will be placed.		
	0.41	Slag Pile Removal	Two large debris piles will be removed.	4 to 2	2-foot cut (2 to 0 feet MLLW)
23	0.06	ENR	ENR material will be placed on existing mudline.	6 to 1	N/A
24/25	0.20	Dredge and Backfill	Elevations shallower than -10 MLLW will be backfilled to grade.	4 to -2	3.5-foot cut (1 feet MLLW)
	0.03	Area-Specific Technology B: Amended Cover	Amended cover material will be placed in structural offset area.	6 to 4	N/A
	0.08	ENR	ENR material will be placed on existing mudline.	1 to 4	N/A
26	0.22	Dredge and Backfill	Elevations shallower than -10 MLLW will be backfilled to grade.	4 to -4	1-foot cut (3 to -5 feet MLLW)
	0.07	Area-Specific Technology B: Amended Cover	Amended cover material will be placed on existing riprap slope.	10 to 2	N/A
27	1.88	Dredge and Backfill	Elevations shallower than -10 MLLW will be backfilled to grade.	20 to -5	2.5- to 4.5-foot cut (15 to -8 feet MLLW)
	0.35	Partial Dredge and Engineered Cap	Engineered cap may be placed along the bank slope.	18 to 4	2- to 4-foot cut (14 to 2 feet MLLW)

Remedial Action Area ¹	Area (acreage)	Intermediate 60% RD Technology Assignment ^{2,3}	Notes	Approximate Existing Elevation Range (feet MLLW)	Required Dredge Depth/Elevation Range ^{4,5}
28	0.22	Dredge	Berth areas will not be backfilled to grade.	-4 to -8	2-foot cut (-6 to -10 feet MLLW)
29	0.15	Dredge and Backfill	Elevations shallower than -10 MLLW will be backfilled to grade.	10 to -5	1.5-foot cut (8 to -7 feet MLLW)
30	0.04	Dredge and Backfill	Elevations shallower than -10 MLLW will be backfilled to grade.	8 to 6	1.5-foot cut (6 to 4 feet MLLW)
31	0.05	Dredge and Backfill	Elevations shallower than -10 MLLW will be backfilled to grade.	3 to 2	2-foot cut (1 to 0 feet MLLW)
32	0.07	Dredge and Backfill	Elevations shallower than -10 MLLW will be backfilled to grade.	6 to -6	1-foot cut (5 to -5 feet MLLW)
33/34/35	0.05	ENR	ENR material will be placed on existing mudline.	8 to -6	N/A
	0.35	Dredge and Backfill	Elevations shallower than -10 MLLW will be backfilled to grade.	8 to -4	1-foot cut (7 to -5 feet MLLW)
ENR (cPAH-only) Areas ⁷	0.17	ENR	ENR material will be placed on existing mudline.	+6 to +8	N/A

Notes:

Backfill means backfill to restore approximate pre-construction elevations.

- RAA 9 is removed for 60% RD and 90% RD.
- From Intermediate (60%) RD BODR, Section 10.2.9: all dredge areas located outside of the FNC and above elevation -10 feet MLLW will be backfilled to grade using suitable habitat material consisting of a mix of sand and gravel (Anchor QEA and Windward 2023)
- From Intermediate (60%) RD BODR, Section 3.7.3, ENR is 12 inches of sand/gravel placed on existing mudline (Anchor QEA and Windward 2023).
- Dredge elevations do not include the 1-foot allowable overdredge depth.
- The elevation range shown in parentheses is approximate for the purposes of this BA.
- The one exception in this table to the remedial technology assignment from the 60% RD is for RAA 14/15/16. Preliminary Phase III PDI data indicate that this area will expand both horizontally and vertically. For BA evaluation purposes, the anticipated larger area footprint has been assumed for this area.
- See Appendix B of the 60% RD BODR for further discussion regarding the cPAH-only area. This area will be treated the same as the other ENR areas identified in this table.

BA: Biological Assessment

cPAH: carcinogenic polycyclic aromatic hydrocarbon

ENR: enhanced natural recovery

FNC: federal navigation channel

MLLW: mean lower low water

PDI: pre-design investigation

RAA: remedial action area

RD: remedial design

RMC: residuals management cover

2.2.1 Dredging

2.2.1.1 Overview

Where dredging and land-based excavation is the remedial technology used, sediment with chemical concentrations above the ROD-defined RALs will be removed. Dredging will occur in all the RAAs, except for RAAs 7, 10, and 23, which will undergo ENR. Land-based excavation is expected to only occur only in RAA 27. The anticipated dredging areas will cover approximately 13.2 acres. However, because the RAA boundaries are being revised during Pre-Final (90%) RD based on new Phase III PDI data, an additional 2.0 acres of dredging has been assumed as a conservative contingency for BA evaluation purposes to bring the total potential dredge area to 15.2 acres. Overall, 98,000 cubic yards (cy) of material is anticipated to be dredged, plus an additional contingency re-dredge volume of 10,100 cy within the same dredging footprint. Contingency re-dredging may be implemented if the post-dredge survey indicates there is missed inventory or high concentrations of dredging residuals. Therefore, the total anticipated dredging volume is 108,100 cy. An additional 21,600 cy of dredged material has been assumed for BA evaluation purposes in case RAA boundary adjustments expand the overall dredge area based on new data. This brings the total potential dredge volume to 129,700 cy. Dredging or excavation required elevations or thicknesses vary based on the RAA location and will range from elevations of +20 feet mean lower low water (MLLW) where excavation may occur at top of banks, down to -25 feet MLLW, not including a 1-foot allowable overdredge tolerance.

All dredge areas will also include either backfilling to grade, placement of an engineered cap, or placement of RMC within the dredge footprint such that the entire dredge prism will have a cover of clean material post-construction. In addition, RMC will be placed within a 20- to 40-foot perimeter from the dredge footprint. Engineered capping and material placement is described in detail in Sections 2.2.3 and 2.2.4, and Figures E2-3a and E2-3b show where dredging will occur and where, backfill, engineered cap, RMC, ENR, and amended cap material will be placed.

2.2.1.2 Construction Methods

Dredging can be accomplished using mechanical dredging methods (e.g., mechanical cranes and barge-mounted excavators), hydraulic dredging methods, and land-based excavation methods. It will ultimately be up to the selected contractor to determine the specific dredging method(s) to be used during construction.

Dredging methods are discussed in more detail in the following sections. As part of the construction activities, the work barges will be placing spuds and other anchors into the substrate to keep the barges stable while completing the work.

Mechanical Dredging

Mechanical dredging will be the primary dredging method. Although the contractor will ultimately select the appropriate equipment for dredging, it is anticipated that different sizes of dredge buckets (e.g., 5 to 10 cy) would be used for dredging in most locations. Mechanical dredges employ a bucket to retrieve sediment from the bed of the waterway, move the sediment up through the water column, and place the sediment into an adjacent haul vessel (such as a barge) for transport and disposal. Two major categories of mechanical dredges are differentiated based on the method of bucket deployment. The first category uses a wire attached to a crane or derrick to lower the bucket to the bed and retrieve sediment. The second category deploys the bucket at the end of the arm of an excavator or backhoe and is sometimes referred to as an articulated fixed-arm mechanical dredge. Mechanical dredges are sometimes referred to by the type of bucket used, such as conventional open clamshell buckets or environmental buckets (Exhibit E2-1). The Technical Guidelines for Environmental Dredging of Contaminated Sediments (USACE 2008) provides more details on environmental buckets as follows:

- **Environmental Bucket:** The environmental (also known as closed) bucket is a sealed bucket (when complete bucket closure is possible) that has minimized bucket openings that allow sediment to escape when closed, as compared to the conventional open bucket. Environmental buckets are not watertight but do significantly reduce water and sediment loss from the bucket during dredging. Recent designs (e.g., Cable Arm) also incorporate a level-cut capability as compared to a circular-shaped cut for conventional buckets. However, minimizing the loss of sediment out of the bucket does not necessarily mean reducing suspended solids or lowering turbidity. As discussed in Wang et al. (2003), environmental buckets have not been proven to reduce suspended sediments in all site conditions. For example, in site conditions with significant debris, environmental buckets may not be able to fully close and tend to lose most or all of the dredged sediment from the bucket as it is raised through the water column. A standard clamshell digging bucket will be more effective at removing debris or dense substrate and be able to close tighter to prevent loss of dredged sediment when removing debris. Environmental buckets are also typically lightweight in construction and not suitable for digging denser or consolidated sediments, requiring multiple passes to remove the material or being ineffective at achieving the required dredge elevations and grades. When used in unconsolidated sediments without significant debris, environmental buckets have been shown to be effective at reducing loss of sediment from the bucket.

The selection of dredge bucket and equipment is site-condition dependent- and contractor-specific and can vary depending on location-specific factors even for a single dredging project. The best equipment for one task may be unsuitable for another task. Dredging soft sediments in open water with minimal debris can be effectively accomplished with a conventional derrick crane and

environmental and closed buckets, although the more closed the bucket is, the more sediment is expelled out the sides of the bucket into the water column as it closes. Constrained dredging in limited access areas may be more appropriately accomplished using an articulated bucket. When using closed environmental buckets (either wire-supported or fixed arm), debris can limit the efficiency of sediment removal by preventing the bucket from fully closing, which will unavoidably increase dredging residuals and negate the benefits of the closed bucket. Although the contractor will ultimately select the appropriate equipment for dredging, the design specifications will require the contractor to use an environmental bucket to the extent practicable.

Hydraulic Dredging

Hydraulic dredging is not anticipated to be used by the contractor during the upper reach remedial construction, but the contractor may propose its use in specific circumstances where site access for mechanical dredging is not feasible (e.g., underpier or riprap slope areas) and the total amount of water generated would be small and controllable. As described in the Feasibility Study (FS; AECOM 2012), hydraulic dredges remove and transport dredged material as a pumped sediment-water slurry. Large debris is typically removed by mechanical dredging methods prior to hydraulic dredging. Then, sediment is dislodged by mechanical agitation, cutterheads, or augers. In very soft sediment, it may be possible to remove surface sediment by straight suction or by forcing the intake into the sediment without first mechanically dislodging the sediment. Most of the loosened slurry is then captured by suction from pumps into an intake pipe and transported through a dredge discharge pipeline to a handling and dewatering facility or a barge for dewatering. Hydraulic dredging impacts on sediment resuspension can be similar to mechanical dredging but typically is observed near the sediment bed.

Barge Dewatering

Dewatering of mechanically dredged materials will be initially performed on the haul barges. Initial dewatering will be accomplished by gravity separation of sediment solids from the water. As noted in the Intermediate (60%) RD, dredge return water from the barge will be filtered to remove suspended solids prior to discharging water from the haul barge. The Intermediate (60%) RD evaluated the potential water quality impacts during dredging and barge discharge operations (Appendix K of the Intermediate (60%) RD BODR [Anchor QEA and Windward 2023], included as Attachment E.4 of this BA) and concluded that the dredging and barge discharge activities are not predicted to exceed Washington State water quality criteria when remedial activities are complying with the turbidity criteria for LDW. Water separated from sediment on the barges may be contained for transport to the transload facility or filtered and returned to the LDW, contingent upon meeting water quality criteria (see Section 2.4.3 for more details on the dewatering requirements).

Exhibit E2-1
Different Mechanical Dredge Bucket Types



Conventional clamshell bucket



Environmental bucket



Articulated environmental bucket (horizontal profile grab)

Debris Pile Removal

Debris piles are located within the dredging footprint of RAAs 18 and 22 covering 0.42 acre. There are three large piles (one in RAA 18 and two in RAA 22) that are presumed to be waste materials from former industrial activities that are identified for removal. Removal of the debris will require temporary shoring of the adjacent bulkhead walls and is expected to occur before dredging of the adjacent sediments within the RAA. The debris will be removed to the mudline plus 2 additional feet below the mudline. Temporary shoring of the adjacent bulkhead walls in these locations will be needed to counteract any loss of passive pressure associated with removal of the debris piles (permanent shoring is discussed in Section 2.2.6.1.2). Suitable habitat material consisting of sand and gravel will be placed to backfill to grade after debris removal.

Land-Based Excavation

Land-based (i.e., “in the dry”) excavation may also be used in intertidal and bank areas but would be limited because of access limitations and duration of low tidal periods. It is expected to be used only in RAA 27 using a derrick crane, a backhoe excavator, or a long-reach stick excavator and conventional land-based earth-moving equipment (e.g., excavators, backhoes, dozers, front-end loaders, and trucks). Excavation in these areas may be coordinated “in the dry” during periods of low tidal elevations; however, depending on weather, tides, scheduling, and contractor production, it will be necessary to conduct some intertidal excavation under water.

It is anticipated that materials removed from the intertidal and bank areas when using land-based equipment may need to be placed into a temporary upland stockpile area or directly into trucks, depending on site access agreements and available upland space. Thus, any land-based work will require upland site access, staging areas, loading operations, and ground transportation. For RAA 27, staging and loading areas would occur in the adjacent upland area, likely west of the existing interior fence. Above the top of bank currently consists mainly of paved areas (Figure E2-1).

2.2.2 *Transport, Transloading, and Disposal of Dredged Material*

2.2.2.1 Overview

Sediment and debris removed from the upper reach will be loaded onto haul barges, or directly into trucks during upland excavation activities, and transported to a transload facility where the material will be offloaded from barges and loaded onto trucks and/or railcars for transportation to a permitted disposal facility. The transload facility is anticipated to be located at a commercial transload facility either in the middle reach of the LDW or another facility located outside of the LDW Superfund Site. Specific transload facility and location will be determined by the selected contractor. The best management practices (BMPs) described in Section 2.4.4 would avoid or minimize release of contaminated material or effluent associated with the transloading and transport of dredged

material. Specifically, the following measures will be required to avoid impacts associated with the transport of material to the transload facility:

- The barges would be required to be watertight during transport (i.e., there would be no discharge of barge water during barge transport).
- The contractor is required to use a permitted facility to offload dredged materials (i.e., permitted for use as a waterfront facility that can offload bulk materials).
- Specifications require the contractor to implement BMPs to prevent spillage of sediment or barge water during offloading (e.g., install spill plates and impermeable liner to catch spillage from transfer operations over the water) and BMPs to control release of water and sediment from land stockpiles back into receiving waters (i.e., to comply with site's National Pollutant Discharge Elimination System [NPDES] or other permits, provide impermeable liner and perimeter barriers around upland stockpiles, and capture all stormwater and stockpile effluent).

Once offloaded to land at the transload facility, additional dewatering (including by gravity and/or amendment) will be performed if determined necessary by the transloading and disposal facilities. Any dredge return water generated by dewatering at the transload facility will be managed (contained and, if necessary, treated) and disposed of in accordance with the facility's permits (i.e., NPDES or other permits) and standards for wastewater disposal.

2.2.2.2 Construction Methods

Dredged material will be transported in water to the transloading facility via haul barges, where it would be offloaded from the barge typically using a crane-mounted bucket and placed into a hopper/conveyor assembly or stockpile area and prepared for upland transportation. Material will then be transported on land using rail or trucks to the permitted disposal facility. Rail transportation includes the transport of dewatered dredged material via railroad tracks using gondolas or containers. Rail transport is desirable when sediment is shipped over long distances, for example, to out-of-state disposal facilities. Truck transportation includes the transport of dewatered dredged material over public roadways using dump trucks, roll-off boxes, or trailers. The contractor will prepare its Remedial Action Work Plan (RAWP) that will describe construction methods and BMPs to comply with the plans and specifications; the contractor's RAWP will be reviewed and approved by EPA.

2.2.3 Engineered Capping

2.2.3.1 Overview

In the Intermediate (60%) RD, one area in the upper reach, RAA 27, has been identified for potential placement of a engineered cap. In this area, existing debris, riprap (armor), and rubble is expected to be removed from the bank as well as the top several feet of armor material and sediment/soils (see photographs in Attachment E.1 for existing shoreline conditions), and the underlying sediment/soils

are expected to be capped over an area of approximately 0.40 acre in the upper intertidal area for no net change in elevation or slope. There is no opportunity in this location to construct a flatter slope due to the location of a slurry cutoff wall that was constructed to support upland remediation requirements (around the inner fence line) that needs to be protected. The Intermediate (60%) RD for RAA 27 bank area may result in removal of all contaminated materials, but verification sampling in the bank area post-removal will be conducted to determine whether there are contaminated sediment/soils that underly the planned removal thickness. The RAA 27 upper intertidal bank area has been designed as an engineered cap to be conservative.

Additionally, based on new Phase III PDI data, the Pre-Final (90%) RD will include an engineered cap in RAA 14/15/16 over an area of 1.0 acre. In this area, a portion of the federal navigation channel (FNC) is expected to require dredging (included in the anticipated overall dredging volume of up to 129,700 cy) and then placement of an engineered cap. The top of the engineered cap surface will be below -19 feet MLLW (deep subtidal) as required by the ROD.

Overall, engineered caps are expected to cover up to 1.4 acres with a potential added area of 0.22 acre as contingency to account for additional engineered cap areas that could be identified in Pre-Final (90%) RD based on new Phase III PDI data.

Engineered capping consists of the physical isolation or immobilization of contaminated sediments, which limits the potential exposure to and mobility of contamination. Sediment caps are designed to reduce potentially unacceptable risks by physical isolation of the contaminated sediment or soil to prevent exposure from direct contact, reduce the ability of burrowing organisms to move contaminants to the surface, provide erosion protection to prevent resuspension of the capped sediment, and/or chemical isolation of contaminated media to reduce exposure from contaminants.

An engineered cap typically consists of an erosion protection layer (e.g., gravel or large rock) overlying a filter material (coarse sand or gravel) overlying a chemical isolation layer (fine to medium sand). In addition, the ROD (EPA 2014) requires the top of the cap to contain suitable habitat material for caps that are at elevation -10 feet MLLW or shallower and 45 centimeters (cm; 1.5 feet) of suitable habitat material in intertidal clamming areas. Below the upper intertidal area of RAA 27 is an intertidal clamming area; however, the upper intertidal area of RAA 27 is an existing steep and armored slope (2 horizontal to 1 vertical [2H:1V]) that is not suitable as a clamming area. An engineered cap is expected to be placed in RAA 27 to replace the existing steep armored slope only in the steep upper intertidal area that is not suitable for clamming; therefore, it is assumed that suitable habitat material is not appropriate to place on top of the steep armored slope, and the steep armored slope portion of RAA 27 will have the same surface condition (riprap) post-construction. The toe elevation of the existing armored slope and the proposed engineered cap would be approximately at elevation +4 feet MLLW. The surface of the RAA 27 engineered cap below mean higher high water (MHHW) will likely be covered by naturally deposited sediment in the long term

(i.e., 2 to 5 years). The deep subtidal engineered cap in RAA 14/15/16 is expected to be covered by naturally deposited sediment based on the depositional environment in the navigation channel. For both of these areas, the habitat surface is expected to return to conditions reflecting what is naturally deposited from upstream.

2.2.3.2 Construction Methods

The engineered capping material and all import materials are expected to be transported either by land from the borrow quarry to the upper reach with dump trucks or by water on barges. The engineered cap material will then be placed over the impacted soil and sediment as follows:

- **Chemical Isolation Layer:** Minimum thickness of 12 inches up to 18 inches of medium- to coarse-grained sand
- **Filter Layer:** Minimum thickness of 6 inches up to 12 inches of angular gravel material
- **Erosion Protection Layer:** 12- to 18-inch layer of armor material (i.e., angular rock armor [quarry spalls to light, loose riprap size])

For placement of imported materials (i.e., engineered cap, backfill, RMC, ENR, and amended cover materials), the specifications will identify performance criteria that the contractor must meet and provide flexibility for the contractor to choose the optimal means and methods that take advantage of their experience and equipment. The contractor will be required to place all materials in a manner that reduces resuspending potentially contaminated bed sediment. Additionally, material will be placed using methods that limit mixing of the placed materials with the bedded sediment as described in Section 2.4.5.

2.2.4 Placement of Backfill, RMC, Enhanced Natural Recovery, and Amended Cover Materials

2.2.4.1 Overview

Clean, imported material, including backfill, RMC, ENR material, and amended cover materials, will be placed in the RAAs as shown in Figures E2-3a and E2-3b. Material placed in areas of existing elevations of -10 feet MLLW or shallower will consist of suitable habitat material (e.g., fish mix/habitat mix) but will need to balance constructability and availability needs. For example, clean, imported material will primarily be sands and gravels. Obtaining and constructing stable slopes using clean silts, clays, and other fine materials is not practical. The surface of the placed materials will eventually be covered by naturally deposited sediment specific to each area placed, so in the long term (i.e., 1 to 5 years) the habitat surface will return to conditions reflecting what is naturally deposited from upstream.

Backfill Material

As described in Section 2.2.1, backfill material will be suitable habitat material consisting of a mix of sand and gravel. Backfill will be placed in dredge areas that are currently at elevation -10 feet MLLW and shallower to return those areas back to their pre-construction elevations and grades to maintain shallow water habitat. Backfill material is expected to be placed over 6.6 acres in the upper reach. However, due to the potential that the RAA boundaries may be revised during Pre-Final (90%) RD based on new Phase III PDI data, an additional 1.1 acres of backfill placement have been assumed for BA evaluation purposes to bring the total potential backfill placement area to be 7.7 acres.

RMC and Enhanced Natural Recovery Material

Medium to coarse sand material will be placed in and around dredged areas as RMC and in ENR areas. A 6- to 12-inch layer of RMC will be placed after dredging is complete within each dredge area and around the perimeter of each dredge area out to 20 feet (or 30 feet in the downstream direction only) from the dredge area (inner dredge perimeter) and may be placed up to 40 feet (or 60 feet in the downstream direction only) from the dredge area (outer dredge perimeter) depending on post-dredge confirmation sampling. RMC thickness on side slopes will consist of a thicker 2-foot layer. RMC will address the thin layer of residuals generated during the dredging operations and provide a new surface substrate of clean sediments.

Residuals refer to the thin layer of disturbed contaminated sediment that remains on the post-dredge surface due to material loss during dredging or due to the inability of the dredge to fully remove the material disturbed during the excavation process. This material generally exhibits very high water content and very low shear strength. Additional dredge passes are typically ineffective at capturing generated residuals. The purpose of residuals management is to provide a clean post-remedial action surface condition with concentrations that are all below surface RALs. Residual contamination can remain within the dredge prism and be resuspended to settle out close to the dredge areas in adjacent sediments. Placing RMC is an effective and standard approach to manage generated residuals. Where sufficiently thin and low-concentration residuals are present, short- and long-term mixing of the clean RMC material into underlying residuals will support attainment of the cleanup criteria. The placement of a clean cover layer accelerates the natural recovery process in the biologically active zone.

RMC is expected to be placed over 12.6 acres (5.2 acres within the dredge footprint and 7.4 acres in the inner and outer dredge perimeter) in the upper reach. This assumes 25% of the outer dredge perimeter would receive RMC based on post-dredge confirmation sampling. An additional 0.7 acre of RMC is assumed as a contingency within the dredge footprint, and 4.7 acres of RMC in the inner and outer dredge perimeter is assumed as a contingency for evaluation purposes in the BA. This

assumes 100% of the outer dredge perimeter would receive RMC based on post-dredge confirmation sampling. The overall total potential RMC placement area is 18 acres.

ENR includes placing a thin layer (i.e., 6 to 12 inches) of clean sand or sand and gravel material over the existing mudline to accelerate natural recovery processes. The proposed action will implement ENR in areas that meet the necessary criteria based on contaminant of concern (COC) concentrations that are above the ROD-defined RALs but below a maximum threshold to use ENR per the ROD. ENR provides a new surface substrate of clean sediments that reduces concentrations in the biologically active zone below the RALs. This cleaner surface material will generally mix with the underlying material through mechanisms such as bioturbation (the disturbance of sediments by organisms). ENR reduces contaminant concentrations in surface sediments more quickly than would happen by natural sedimentation processes alone.

ENR material is expected to be placed over 0.41 acre in the upper reach. An additional 0.21 acre of ENR material placement is assumed as a contingency for evaluation purposes in the BA, for a total potential ENR placement area of 0.62 acre.

Amended Cover Material

Amended cover material will be placed in portions of RAAs 18, 24, and 26 that are adjacent to existing structures or armored slopes and where dredging offsets are required (i.e., dredging is not possible due to structural or stability concerns). A 6- to 12-inch layer of cover material consisting of sand and gravel assumed to be amended with 1.5% of granulated activated carbon (by weight) will be placed to reduce the bioavailability of PCBs at the surface of the cover over a 100-year period. Amended cover material is expected to be placed over 0.12 acre. An additional 0.06 acre of amended cover placement is assumed as a contingency for evaluation purposes in the BA, for a total potential amended cover area of 0.18 acre.

2.2.4.2 Construction Methods

For placement of backfill, RMC, ENR, and amended cover materials, the specifications will identify performance criteria that the contractor must meet and provide flexibility for the contractor to choose the optimal means and methods that take advantage of their experience and equipment. The contractor will be required to place all materials in a manner that reduces resuspending potentially contaminated bed sediment. Additionally, material will be placed using methods that limit mixing of the placed materials with the bedded sediment. These include using a barge-mounted, crane-operated clamshell or spreader box ("skip box"), or variable-speed telebelt, as detailed in Section 2.4.5. Exhibit E2-2 depicts in-water placement of clean material using typical marine equipment. The material will be placed with sufficient control to meet the design thicknesses and required backfill elevations for each type of material.

Exhibit E2-2

In-Water Placement of Clean Material Using Typical Marine Equipment



Controlled bucket placement



Variable-speed telebelt placement

2.2.5 *Monitored Natural Recovery*

MNR relies on natural processes, such as burial of low to moderately contaminated sediments by cleaner sediments from upriver of the cleanup site. Per the ROD, MNR relies on natural processes to reduce ecological and human health risks to acceptable levels while monitoring recovery of sediments over time to determine remedy success. Within the LDW, natural burial of contaminants through sedimentation from upstream is the primary natural recovery mechanism. MNR will be used in all areas of the upper reach below ROD-defined RALs (i.e., that are not remediated through engineered capping, dredging, or ENR). For all areas where MNR is used, long-term monitoring of surface sediments (top 10 cm) will be implemented to evaluate whether cleanup levels are being achieved.

No construction activities are associated with the MNR technology.

2.2.6 *In-Water Structure Modifications*

2.2.6.1 Overview

2.2.6.1.1 *Pile Removal and Replacement*

Piles are anticipated to be removed and replaced with a vibratory hammer to facilitate access for dredging at some locations. Any piles that are removed that support Tribal net fishing will also be replaced and designed to resist forces imposed by the nets, which will be evaluated in coordination with Tribal fishers. The need for vertically loaded replacement piles has not been identified within the upper reach. Piles are assumed to be replaced to provide “in kind” functions to piles that are removed; however, because timber piles require chemical treatment to limit decay, timber piles will be replaced with steel piles during replacement. There may also be a need for isolated removal for derelict piles that do not have any identified current or future use but may be inhibiting access for nearby remediation. The following pile removal and/or replacement activities are anticipated to occur:

- Between RAAs 24/25 and 26, two 10-inch diameter timber piles will be removed, and one will be replaced with a 14-inch steel pile. These activities will occur in the intertidal zone.
- In RAA 27, one timber dolphin consisting of three 10-inch timber piles will be removed and not replaced. One single 10-inch timber pile will be replaced with a 14-inch steel pipe pile for Tribal fishing use. These activities will occur in the intertidal zone.
- In RAAs 30 and 31, nine 10-inch creosote-treated timber piles will be removed from the LDW and not replaced. These activities will occur in the intertidal zone.
- In RAA 32, two 10-inch timber piles will be removed and not replaced in the intertidal zone.
- In RAA 33/34/35, at least thirteen 10-inch timber piles will be removed and not replaced in the intertidal zone.

For conservative evaluation purposes in this BA, we have assumed that approximately ten 36-inch steel pipe piles could be installed temporarily during construction for contractor’s vessel moorage in deep subtidal areas outside of the FNC. These may be installed by the contractor and used to tie equipment up to when not in use.

2.2.6.1.2 *Reinforcement of a Bulkhead Wall*

Shoring will be needed to reinforce an existing bulkhead wall in RAA 22 (see discussion of need for reinforcement in Section 2.2.1.2 “Debris Pile Removal” subsection). Three options are being considered for shoring of the existing bulkhead wall:

- **Tieback Anchors:** The anchors would be installed above water level and would not result in a loss of habitat.

- **Bracing Piles:** Eight to sixteen piles of 8- to 10-inch diameter would be installed along the existing bulkhead wall.
- **Shoring Sheetpile Wall:** If tieback anchors or bracing piles are not feasible or sufficient to be used as shoring along RAA 22, a shoring sheetpile wall would be driven along a 160-foot section of shoreline approximately 1.5 feet waterward of the existing bulkhead. The area between the existing and replacement wall will be filled in with import material.

Shoring is needed to keep the existing bulkhead wall stable during removal of the debris pile. For the purposes of the BA, we assume that a shoring sheetpile will be used to reinforce the existing bulkhead wall because this option would represent the greatest loss of intertidal habitat.

2.2.6.1.3 *Outfall Bank Protection*

Existing outfall discharge locations may need to be armored or supported on splash pads/aprons or other flow energy dissipator systems to protect the bank from erosion due to the outfall flow discharge. For BA evaluation purposes, we have assumed that bank protection material will cover an area of 540 square feet and is anticipated to be used on one outfall each in RAAs 13, 18, 26, and 33/34/35, for a total of 2,160 square feet (0.05 acre).

2.2.6.2 **Construction Methods**

Piles will be removed using vibratory extraction methods, direct-pull methods or will be cut at or below the mudline. Piling removal is expected to be conducted with a crane mounted on a barge. If a pile is unable to be completely removed using the vibratory or pulling methods, the pile will most likely be cut approximately 2 feet below the mudline. Temporary piles will be removed using vibratory methods.

Piles will be installed using vibratory methods, which is suitable for the substrate conditions within the LDW. An impact hammer will not be required to drive piles to design depths and will not be used to proof any piles.

The bracing piles or sheetpile wall that may be used to reinforce the existing bulkhead wall in RAA 22 will be installed using vibratory methods. If tieback anchors were used to reinforce the existing bulkhead wall in RAA 22, the construction would be completed with drilling equipment above the waterline.

Outfall bank protection materials will be placed using typical earthwork equipment (excavator) at low tide in the dry.

2.2.7 *Construction Access*

Construction access is expected to occur from the waterside for most of the proposed remedial activities. However, RAA 13 and RAA 27 are anticipated to require construction access from the

upland. Upland access to RAA 13 (if used) is expected to be through the South Park Marina. For RAA 27, existing vegetation that may be disturbed for access to implement remedial activities includes 1,800 square feet of trees that line the parking lot. Currently, non-native shrubs, such as Himalayan blackberry (*Rubus armeniacus*) and butterfly bush (*Buddleia davidii*), are set back from the channel at the top of the riprap along RAA 27. In addition, there are similar non-native shrubs at the top of the existing bulkhead wall at RAA 22 that may be disturbed during reinforcement of the bulkhead wall. Any shoreline vegetation disturbed from implementation of remedial actions from the landside will be replaced with native vegetation species to the extent feasible based on site access agreements. Photographs of the shoreline in RAA 13, RAA 27, and RAA 22 are shown in Attachment E.1.

2.2.8 Summary of Remedial Activities

Overall, approximately 28.1 acres of the approximately 132-acre upper reach could be impacted by remedial activities, including dredging, engineered capping, and placement of backfill, RMC, ENR, and amended cover materials, as summarized in Table E2-1. Additionally, up to thirty 10-inch timber piles are expected to be removed, and up to two 14-inch steel pipe piles are expected to be installed as replacements (Table E2-2). Fifteen of the 10-inch timber piles that are expected to be removed are assumed to be creosote-treated). This results in a net gain of 14.22 square feet of intertidal habitat from the permanent decrease in pile areal coverage. Approximately 10 temporary piles may be installed during construction for moorage in deep subtidal areas outside of the FNC. For the purposes of this BA, reinforcement of an existing bulkhead wall is assumed to use a new sheetpile wall and result in a loss of 240 square feet of intertidal habitat (see discussion of three options for reinforcing the existing bulkhead wall in Section 2.2.6.1.2). Finally, 0.05 acre (2,160 square feet) of bank protection are expected to be permanently placed at outfalls to protect the remediated bank from erosion. These areas will be within areas of dredging and/or material placement, so they will not be new areas of construction impact. Overall, 2,386 square feet (net) will be impacted by in-water structure modifications.

**Table E2-1
Summary of Area of Impact for Dredging and Material Placement Activities**

Habitat Type	Area of Impact – Dredging or Excavation and Material Placement ¹ (acres)	Contingency ² Area of Impact – Dredging or Excavation and Material Placement (acres)	Area of Impact – Partial Dredging and Engineered Cap (acres)	Contingency ² Area of Impact – Partial Dredging and Engineered Cap (acres)	Area of Impact – Material Placement ³ (acres)	Contingency ² Area of Impact – Material Placement (acres)	Total Area of Impact (including contingency) (acres)
Riparian (higher than +11.3 feet MLLW)	0.004	0.001	0.3	0	0.2	0.1	0.6
Intertidal (-4 to +11.3 feet MLLW)	4.2	0.6	0.1	0	2.9	1.9	9.7
Shallow Subtidal (-10 to -4 feet MLLW)	1.3	0	0	0.22	1.8	1.1	4.4
Deep Subtidal (deeper than -10 feet MLLW)	6.3	1.2	1.0	0	3.0	1.9	13.4
Total	11.8	1.8	1.4	0.22	7.9	5.0	28.1

Notes:

- Each dredging and material placement area will be covered with either RMC (5.2 acres [0.7 acre of contingency]) or backfill material (6.6 acres [1.1 acres of contingency]) after dredging is complete; therefore, dredging and material placement is combined in these areas to avoid double counting area of impact. Partial dredging and engineered cap areas may receive an engineered cap after dredging. The total dredging area is equal to the dredging and material placement area plus the partial dredging and engineered cap area (13.2 acres [2.0 acres of contingency]).
- Contingency areas are estimated to account for the potential that the RAA boundaries may be revised during Pre-Final (90%) RD based on new Phase III PDI data.
- Material placement includes placement of ENR material over 0.41 acre, placement of amended cover over 0.12 acre, and 7.4 acres of RMC outside of the dredge area in the inner dredge perimeter that automatically receives RMC and the outer dredge perimeter that may receive RMC depending on the results of post-dredge confirmation sampling. For area of impact, it is assumed that 25% of the outer perimeter will require RMC. Contingency material placement includes placement of ENR material over 0.21 acre, placement of amended cover over 0.06 acre, and 4.7 acres of RMC outside of the dredge area in the inner dredge perimeter that automatically receives RMC and the outer dredge perimeter that may receive RMC depending on the results of post-dredge confirmation sampling. For contingency area of impact, it is assumed that 100% of the outer dredge perimeter will require RMC.

ENR: enhanced natural recovery
MLLW: mean lower low water
PDI: pre-design investigation

RAA: remedial action area
RD: remedial design
RMC: residuals management cover

Table E2-2
Summary of Permanent In-Water Structure Installation and Removal

RAA	Habitat Type	Piles to Be Removed			Piles to Be Installed			Outfall Bank Protection on Splash Pad Aprons ¹	Existing Structure Reinforcement				Net Aquatic Area Impacted (sq ft)
		Number and Size	Type	Aquatic Area ² Opened Up (sq ft)	Number and Size	Type	Aquatic Area Impacted (sq ft)		Aquatic Area Impacted (sq ft)	Length to be Removed (feet)	Length to Be Installed (feet)	Offset ³ (feet)	
22	Intertidal	0	0	0	0	N/A	0	0	0	160	1.5	240	240
24/25, 26	Intertidal	2-10 inches	timber ⁴	1.09	1-14 inches	steel pipe	1.07	0	0	0	0	0	-0.02
27	Intertidal	3-10 inches	timber ⁴	1.63	0	N/A	0	0	0	0	0	0	-1.63
27	Intertidal	1-10 inches	timber ⁴	0.55	1-14 inches	steel pipe	1.07	0	0	0	0	0	0.52
30/31	Intertidal	9-10 inches	timber ⁴	4.91	0	N/A	0	0	0	0	0	0	-4.91
32	Intertidal	2-10 inches	timber ⁴	1.09	0	N/A	0	0	0	0	0	0	-1.09
33/34/35	Intertidal	13-10 inches	timber ⁴	7.09	0	N/A	0	0	0	0	0	0	-7.09
13, 18, 26, 33/34/35	Intertidal	N/A	N/A	N/A	N/A	N/A	N/A	2,160	0	0	0	0	2,160
Total	N/A	30	N/A	16.36	2	N/A	2.14	2,160	0	160	1.5	240	2,386

Notes:

- Up to four outfall bank protection splash pad aprons are expected to be installed, each consisting of an area of 540 sq ft.
- Area of a circle = $\pi * r^2$.
- Waterward offset from existing bulkhead. The installation of a shoring sheetpile wall represents the greatest loss of habitat of the three options presented in Section 2.2.6.1.2.
- Timber piles in RAAs 24/25, 26, 27, and 30/31 are assumed to be creosote-treated. Timber piles in RAAs 32 and 33/34/35 are not creosote treated.

N/A: not applicable

RAA: remedial action area

sq ft: square foot

2.3 Project Timing

Project construction for the upper reach remedial action is expected to begin in fall 2024 and require three construction seasons (2024 to 2025, 2025 to 2026, and 2026 to 2027) to complete. In-water construction activities will occur during in-water work window designated for the LDW (to be determined by EPA in consultation with the Services but anticipated to be from approximately October 1 to February 15, or an approved extension) that are set to protect migrating juvenile salmonid species and Washington Department of Fish and Wildlife (WDFW) priority species.

Construction start dates each season will be coordinated with applicable Tribes to minimize interruption of Tribal netfishing in their Usual and Accustomed (U&A) area. Mobilization would take place prior to the start of the in-water work season, and demobilization will occur after the end of each in-water work season. Construction activities will generally move from upriver to downriver, but the selected contractor will be allowed to move between areas as necessary to complete the remedial construction efficiently.

2.4 Impact Avoidance, Minimization, and Conservation Measures

Impact avoidance and minimization measures apply to remedial technologies implemented as part of the proposed action, including dredging; barge loading and dewatering; transport and transloading of dredged material; engineered capping; placement of backfill, RMC, ENR, and amended cover materials; piling removal/installation; and any associated in-water work. The avoidance and minimization measures described in this section are measures taken to first avoid impacts to the aquatic environment, but where impacts may be unavoidable, measures to minimize the impacts are proposed.

2.4.1 General

The following impact avoidance and minimization measures will apply to all in-water construction activities, including dredging; engineered capping; placement of backfill, RMC, ENR, and amended cover materials; and in-water structure removal and installation:

- All in-water work will be conducted during a regulatory in-water work window when juvenile salmonids and WDFW priority species are expected to either not be present or present only in low numbers. The in-water work window designated for the LDW is anticipated to be from approximately October 1 to February 15. The work window requirement is expected to apply to activities occurring in the water that have the potential to impact listed species. Coordination with federal and state resource agencies and co-managers will occur to ensure any deviations in the timing of fish runs are accounted for in work start and end dates to aid in balancing the overall impact of the work to be performed (e.g., a small extension of the window to avoid an entire additional field season of work for a particular area may be of an

overall lesser impact and preferred). Work that is expected to result in limited impacts will not be completed during the in-water work window. This type of work includes transport and transloading of dredged material, removal and replacement of structures (except for pile removal and/or installation), and activities occurring in the dry or over the water with proper measures in place to prevent construction materials from entering the water.

- Water quality in the action area will be monitored and compared against applicable water quality standards (Washington Administrative Code [WAC] 173-201A-210). This includes required limits measured in the water column for turbidity, dissolved oxygen (DO), pH, and temperature, and for select COC criteria (e.g., PCBs) pursuant to the Clean Water Act (CWA) Section 404 ARAR Memorandum that will be issued by EPA prior to implementation and the *Water Quality Monitoring Plan (WQMP)* completed as part of the Pre-Final (90%) RD (Volume II, Part I, Appendix A) and Final (100%) RD.
- Operational controls will be used for control of turbidity and resuspended sediment. For example, construction activities can be progressively slowed to minimize sediment suspension until turbidity exceedances are no longer detected outside of the compliance boundary, or dredging cycle times can be increased to decrease turbidity plumes until the suspended sediment settles.
- A spill containment and control plan will be kept on site during construction activities and will contain notification procedures, specific cleanup and placement instructions for different products, quick response containment and cleanup measures that will be available, proposed methods for placement of spilled materials, and employee training for spill containment.

2.4.2 Dredging

- Removal of large debris, if practicable, will be required prior to dredging in identified debris areas. Debris caught in dredging equipment can cause additional resuspension and release of contaminated sediments. Note, this operational control is not appropriate for buried debris below the mudline; debris removal itself generates turbidity. Practicability of debris removal will depend on field conditions.
- Multiple bites by the dredge bucket on the sediment bed before the bucket is raised will be prohibited so that bed disturbance by the bucket is reduced.
- "Sweeping" (i.e., dragging a bucket or beam), or leveling of the sediment bed by pushing bottom sediments around with the dredge bucket to knock down high spots to achieve required dredge elevations, will be prohibited. Instead of leveling to remove high spots, the contractor may be required to make an additional dredging pass to remove any high spots that are identified during progress surveys.
- Interim underwater stockpiling of dredge material will be prohibited (i.e., taking small dredge cuts and temporarily stockpiling material at the mudline in a mound to allow the dredge

operator to grab a fuller bucket). Such action could create a pile of loose sediment that can easily be resuspended.

- Overfilling of conventional clamshell and environmental buckets will be prohibited. When the dredge bucket penetrates soft sediment, there is the potential for the bucket to penetrate beyond the designed digging depth of the bucket. If the bucket is overfilled, a portion of the dredged material cannot be contained within the bucket and may be lost and resuspended in the water column as the bucket is raised. If bucket overloading is observed, measures will be taken to reduce this potential (e.g., decrease the maximum cut depth).
- The contractor will be required to use an environmental bucket as the primary method for dredging. However, the contractor may propose to use a standard clamshell digging bucket when site conditions are not appropriate for the environmental bucket (i.e., buried debris or dense sediment conditions).
- Specific dredging procedures (e.g., shallow top-to-bottom cuts) will be specified to prevent the potential for slope failures and slope movement that would cause excessive sediment resuspension.
- Additional BMPs to reduce sediment resuspension that may be employed as needed to manage water quality and meet turbidity criteria include the following:
 - The rate of dredge bucket descent and ascent will be slowed down; however, this BMP needs to be carefully implemented based on the physical characteristics of the sediments being removed (e.g., soft sediments versus hard digging, presence of debris, or water depths) because limiting the velocity of the descending bucket in dredge operations may reduce the volume of sediment that is picked up by the bucket, thus requiring multiple bites to remove the project sediment and increasing the overall project duration and associated duration of short-term water quality impacts.
 - After dredged sediment is placed into the haul barge, the opened bucket will be held open for a short period of time above the barge to allow residual materials from the bucket to fall into the barge.
 - Use of low power for tug operations in the shallow subtidal and intertidal zones will be recommended during barge relocation, movement for maritime traffic, and dredge/material barge replacements to reduce sediment resuspension.
- If hydraulic dredging methods are used, the following measures will be implemented to reduce the probability of entrainment:
 - The dredge will not be operated when the cutter or suction head is off the river bottom.
 - The cutter or suction head will be placed on the bottom of the water column or a maximum of 3 feet from the bottom when necessary.
 - The pumps will only be turned on when necessary.

2.4.3 *Barge Loading and Dewatering*

Measures that will be required to reduce the potential for spillage of dredged material during haul barge filling and dewatering include the following:

- Uneven filling or overfilling of barges will be prohibited to prevent spillage of sediment and unfiltered dredge return water from barges.
- Haul barges will be loaded evenly to maintain barge stability.
- Once the barge is loaded and stabilized, it will be inspected for sediment adhered to the outside of the barge that could fall off the barge during transport. Contractor personnel will conduct a visual inspection around the entire barge deck area to remove such sediment before moving the barge out of the dredging site.
- For dredged sediment dewatering occurring on haul barges, the dredge return water will be discharged back into the LDW within the active dredging work zone. The contractor will be required to equip the barges with appropriate BMPs (e.g., filtering all water prior to discharge to remove suspended solids from the dredge return water) to maintain compliance with water quality criteria.

2.4.4 *Transport and Transloading of Dredged Material*

Measures will be required to reduce the potential loss of dredged material during transport, transloading of dredged materials off the barge (at the transload facility) or from a temporary upland stockpile area (if intertidal sediment and shoreline bank soil excavation occurs). Measures will also be required during transport of dredged/excavated material from the transload facility to the approved disposal facility. Such measures include the following:

- All barges transporting dredged materials will be certified as seaworthy by a marine inspector prior to barge use, and no unfiltered dredge return water will be allowed to discharge into the LDW in transit to the transload facility.
- Any effluent generated by dewatering at the transload facility, or via hydraulic or land-based dredging, will be managed (contained and, if necessary, treated) and disposed of in accordance with facility permits or authorizations for wastewater disposal.
- To prevent dredged material spillage when transloading materials between the haul barge and transload facility, spill aprons will be set up and used to direct bucket spillage back into the barges or onto the uplands and not into the adjacent water.
- Inside the transload facility, material captured by spill aprons will land on secondary containment areas outside the area typically traveled by trucks or railcars to avoid tracking material on tires or wheels.
- The bucket swing path from the haul barge to the upland transload facility will not be allowed to occur over open water. The contractor will need to swing the offloading bucket over either

the derrick barge or a “spanning” barge that will capture any spillage from the offloading bucket.

- Visual monitoring will be performed by the contractor to determine if the transport of dry dredged/excavated materials creates a dust concern, and if so, dust suppression controls will be employed (e.g., covering the haul trucks or containers).
- When wet materials are transported over land, haul trucks or railcar containers will be lined or sealed to reduce the chance of sediment or water release during transport.
- For dredge material transfer from a temporary upland stockpile area, truck loading will occur within the transfer area, and the trucks will be decontaminated and inspected within a designated contained footprint before they leave the transfer area.
- Trucks or railcars will not be overloaded to prevent loss due to spilling.
- Truck loading areas will be swept frequently to reduce the probability of truck tires tracking contaminated materials outside of the loading areas.
- The trucks, truck loading area, and access route will be visually inspected to confirm there is no loss of material from the trucks prior to releasing the truck from the transload facility to public roads.
- Tires and truck or railcar bodies will be cleaned to remove sediment, if necessary, before leaving the site (e.g., dry brushing and tire/wheel washing).
- Containment areas will be designed so that fluids from the transloading operations can be collected.
- The effluent collected from transloading operations will be disposed of with the other waste generated from the site (included with the sediment for disposal) or sampled, treated, and discharged in accordance with approved permits of the transload facility or disposed at a permitted commercial facility.

2.4.5 *Placement of Engineered Cap, Backfill, RMC, ENR, and Amended Cover Materials*

Impact avoidance and minimization measures and conservation measures that may be applied to this work include the following:

- A sand and gravel habitat layer (e.g., fish/habitat mix) will be placed on top of the cap armor layer in areas at elevation -10 feet MLLW or shallower (except in RAA 27; see Section 2.2.3.1) to enhance substrate for benthic invertebrates, which are prey for juvenile salmonids.
- The specifications for the imported material will include a requirement for the materials to consist of clean, granular material free of roots, organic material, contaminants, and all other deleterious material. This requirement will minimize the amount of fines being placed and reduce the potential for elevated turbidity during placement.

- Place engineered cap, backfill, or RMC material as soon as possible after dredging to minimize recontamination risk from dredge residuals.
- To ensure proper material placement, import materials will be placed in a controlled and accurate manner.
- The following methods are typical placement methods for engineered caps, or combination of methods, that the contractor may use to limit disturbance of the bottom sediments during engineered cap material placement operations:
 - Placing individual engineered cap layers by lowering the cap material close to the sediment bed surface and slowly opening the bucket to provide more accurate placement of each discrete cap layer
 - Placing larger armoring layer material from near the sediment bed instead of from the surface of the water column
 - On slopes, placing materials from the bottom of the slope and working up the slope to reduce the potential for slope sloughing
 - Placing materials using land-based earthwork equipment from the shoreline if site access is feasible
 - In intertidal areas, working at low tides in the dry when possible to limit potential water quality impacts and better control placement accuracy
- The following methods are typical backfill, RMC, ENR, and amended cover placement methods, or combination of methods, that the contractor may use to limit disturbance of the bottom sediments during material placement operations:
 - Placing materials with a barge-mounted, crane-operated clamshell or a spreader box ("skip box")
 - The clamshell placement method involves slightly opening the bucket and slowly releasing the sand from the bucket slightly below or above the water surface as the operator moves the bucket in a sweeping motion from side to side, allowing sands to fall through the water column, which helps spread out the placed materials and help reduce the energy of the placed material hitting the bed.
 - Placing materials from a barge with a variable-speed telebelt, which would project material over the placement area at a controlled speed to reduce the energy of the placed material hitting the bed
- Bathymetric surveying may be used in deeper water depth areas to verify adequate placement coverage during and following material placement.
- Engineered cap, backfill, ENR, RMC, and amended cover materials must be approved before use; therefore, testing of the borrow source material will be required of the contractor to demonstrate that the source material meets specifications (i.e., chemical and physical criteria).

2.4.6 Pile Installation

The following measures will be implemented during pile installation activities, to the extent practicable:

- Piles will be installed using vibratory methods that are suitable for the substrate conditions within the LDW. Vibratory methods are typically preferred because they reduce impacts to salmon, steelhead, and bull trout.
- An impact hammer will not be required to drive piles to design depths and will not be used to proof any piles.
- Hydraulic jetting devices will not be used to install pilings.

2.4.7 Pile Removal

The following measures will be implemented during pile removal activities, to the extent practicable:

- All pile removal work will be confined to within a floating containment boom.
- When possible, removal of treated wood piles will occur in the dry or during low water conditions. Doing so increases the chances that the piles will not be broken (greater visibility by the operator) and increases the chances of retrieval if piles are broken.
- The crane operator will remove piles slowly. This will minimize turbidity in the water column and sediment disturbance.
- The operator will minimize overall damage to treated wood piles during removal. In particular, treated wood piles must not be broken off intentionally by twisting, bending, or other deformation. This will help reduce the release of wood-treating compounds (e.g., creosote) and wood debris to the water column and sediments.
- Upon removal from the substrate and water column, piles will be moved into the containment area for processing and disposal at an approved off-site upland facility.
- Piles will not be shaken, hosed off, stripped, scraped off, left hanging to drip, or any other action intended to clean or remove adhering material from the piles.
- The operator will make multiple attempts to remove a pile before resorting to cutting.
- Vibratory extraction will be used because it is the preferred method of pile removal; it causes the least disturbance to the riverbed and typically results in the complete removal of the pile from the aquatic environment.
- The operator will “wake up” the pile by vibrating it to break the skin friction/suction bond between the pile and sediment. This bond-breaking avoids pulling out a large block of sediment and possibly breaking off the pile in the process.
- Excavation of sediment from around the base of a pile may be required to gain access to portions of the pile that are sound and to allow for extraction using direct-pull methods. Excavation may be performed in the dry at low tide or in the water using divers. Hydraulic

jetting devices will not be used to move sediment away from piles to minimize turbidity and releases to the water column and surrounding sediments.

- If necessary, piles will be cut at or below mudline, with consideration given to the mudline elevation, slope, and stability of the site. Hand excavation of sediment (with divers in subtidal areas) is needed to gain access for cutting equipment. To minimize turbidity and releases to the water column and surrounding sediments, hydraulic jetting devices will not be used to move sediment away from the pile.

3 Action Area

The action area is defined as the area to be affected directly or indirectly by the federal action (50 Code of Federal Regulations [CFR] 402.02). This area is the geographic extent of the physical, chemical, and biological effects resulting from the proposed action. The action area boundary is thus set as the limits of the proposed action effects, as discussed in the following sections. The terrestrial extent represents the distance at which in-air noise from construction activities would attenuate to background sound levels. The impact expected to have the largest aquatic extent is underwater noise and the resuspension of sediments during dredging. Therefore, the aquatic extent of the action area is derived based on the loudest potential project source noise, a vibratory pile driver, and it extends to aquatic areas where noise will be elevated above background levels. The aquatic extent of the action area is also derived based on the potential downstream extent that resuspended sediments may travel during dredging. The terrestrial and aquatic extents are described in more detail in the following sections.

3.1 Terrestrial Extent

Average measured in-air noise levels for common construction equipment to be used for this project (e.g., typical land-based equipment including excavators, loaders, derrick crane, dump trucks) range from 79 to 81 A-weighted decibels (dBA) measured at 50 feet (WSDOT 2021). The average measured in-air noise level for vibratory pile driving is approximately 105 dBA measured at 50 feet, representing the loudest potential noise-generating activity of the project.

The project setting is characterized by intensive urban land uses near the project site, including the King County International Airport. There are many sources of ambient terrestrial noise within the action area. Regular marine and upland commercial traffic in and around the LDW are ongoing sources of noise that affect the in-air extent of the action area. Daytime ambient noise levels in the area have not been measured as part of this project, but the Washington State Department of Transportation (WSDOT 2021) indicates that high-density urban areas have typical ambient sound levels of approximately 78 dBA. This is likely conservative given the highly industrial nature of the project area.

Noise attenuates to ambient, or background, levels as the distance from the source of the noise increases. In areas of soft ground cover, the standard reduction for point-source noise is 7.5 dBA for each doubling distance from the source. In areas of hard ground cover, the standard reduction for point-source noise is 6 dBA for each doubling distance from the source. The project area is primarily surrounded by urban areas and water, which are considered a mix of soft and hard ground cover, so calculations using hard ground cover are used here to be conservative. Using a 6-dBA reduction for each doubling of distance (WSDOT 2021), in-air noise conditions were calculated for the distances at

which they were expected to attenuate to ambient conditions using a spreading loss model, as follows:

*Distance of attenuation = Distance of measurement * (10^{Point-source noise – ambient noise}/Spreading loss coefficient)*

*1,119.4 feet = 50 feet * (10^{105 dBA - 78 dBA}/20)*

Where the spreading loss coefficient of 20 is equivalent to a 6 dBA reduction for each doubling of distance

Sound levels from the loudest anticipated construction activity generally attenuate to background levels within approximately 1,119 feet from the project site. Therefore, 1,119 feet is used as the in-air extent (Figure E3-1). For the purposes of defining the action area, it is assumed temporary piles could be placed in any RAA, so the extent of in-air noise is delineated from the outermost boundary of where work will be occurring.

3.2 Aquatic Extent

The farthest-reaching effects of the proposed action are expected to be noise and the extent of resuspended sediments from dredging; thus, the in-water portion of the action area is defined by these limits.

Pile driving is expected to generate underwater noise that exceeds background conditions. Pile driving is expected to occur as described in Section 2.2.6.1.1. Pile driving will occur intermittently over the course of construction during the approved in-water work window. The potential area where sound generated from the project could propagate above ambient levels was calculated using tools available from the National Oceanic and Atmospheric Administration (NOAA) (Attachment E.3). The waterway is very active, and human factors that may contribute to background noise levels include public, private, and commercial ship traffic. Natural actions that contribute to ambient noise include waves, wind, rainfall, current fluctuations, chemical composition, and biological sound sources (Carr et al. 2006). Background noise levels are compared to the NOAA threshold levels to determine thresholds of harassment and injury for aquatic species. Due to a lack of site-specific background sound level data, a standard value of 120 decibels in root-mean-square pressure (dB RMS) is used. The practical spreading loss model (4.5-decibel [dB] noise reduction per doubling distance) was used to estimate the extent of underwater sound from the project (WSDOT 2021). Both timber and steel piles will be removed and steel piles will be installed as part of this project. Vibratory installation of steel piles is expected to cause the greatest sound of these activities; therefore, sound estimates for driving 36-inch steel pipe piles are used in calculations. Because no site-specific data are available for estimating the source sounds of 36-inch steel piles, analyses were conducted using source sound estimates from *Technical Guidance for Assessment and Mitigation of the Hydroacoustic*

Effects of Pile Driving on Fish (Caltrans 2015). Installation of 36-inch steel piles is expected to generate underwater sounds of approximately 190 dB RMS measured at 33 feet. Using the practical spreading loss model described in the previous section, and a transmission loss coefficient of 15 (consistent with a 4.5-dB reduction per doubling distance), underwater noise would attenuate at a distance of 1,522 feet in open water. However, underwater noise also attenuates when it reaches land masses; therefore, underwater noise exceeding background levels will reach to parts of the LDW that are within line-of-site of in-water construction activities. This extends to RM 1.5 downstream and RM 5.2 upstream, as shown in Figure E3-1. For the purposes of defining the action area, it is assumed temporary piles could be placed in any RAA, so the extent of underwater noise is delineated from the outermost boundary of where work will be occurring. In addition, during dredging of the RAAs, sediments containing chemical concentrations above the RALs could be resuspended and travel outside of the immediate area of dredging. The larger sized particles (e.g., sand) are expected to settle close to the location of dredging. However, the smaller-sized particles (e.g., silt and clay) could remain suspended in the water column and travel downstream. Water quality modeling (Attachment E.4) indicates that water quality criteria will be met within 150 feet from the point of dredging. It is very unlikely that suspended contaminants can migrate downstream and be detectable at Elliott Bay, which is located more than 4 miles downstream from the downstream boundary of the upper reach.¹ Nonetheless, EPA is extending the action area out of deference to the Services to conservatively address concerns related to potential impacts to Southern Resident killer whales, rockfish (yelloweye and bocaccio), and sunflower sea star (Figure E3-1).

¹ LDW Superfund Site RM 0.0 starts at the upstream end of Harbor Island; both the East and West Waterways are downstream of RM 0.0 and are longer than 1 mile.

4 Environmental Baseline

The “environmental baseline” includes the past and present impacts of all federal, state, or private actions and other human activities in the action area, the anticipated impacts of all proposed federal projects in the action area that have already undergone formal or early ESA Section 7 consultation, and the impact of state or private actions that are contemporaneous with the consultation in process (50 CFR 402.02). Any proposed action must be evaluated in the context of the existing environmental baseline to determine whether the proposed action, when added to the “present and future human and natural contexts,” will jeopardize listed species. Where baseline conditions imperil a species, a new action can be taken as long as it does not “cause some new jeopardy,” “deepen the jeopardy by causing additional harm,” or cause “some deterioration in the species’ pre-action condition” (*National Wildlife Federation v. NMFS* 2008).

Throughout the 1900s, the watershed area and flow volumes to the Duwamish River were reduced by approximately 70% as a result of the diversion of the river’s tributaries (Kerwin and Nelson 2000). In 1906, the White River was diverted to the Puyallup River to help control flooding (Harper-Owes 1983). In 1916, the Black River, which was fed by the Cedar River and Lake Washington, was reduced to a minor stream when the level of Lake Washington was lowered through the construction of the Lake Washington Ship Canal, and the Cedar River was subsequently diverted to Lake Washington (Harper-Owes 1983). Today, the Green River is the primary source of water for the Duwamish River. The Duwamish River originates at the confluence of the Green and Black rivers near Tukwila, Washington, and flows northwest for approximately 12 miles prior to discharging into Elliott Bay in Puget Sound. The project is located within the Duwamish estuary, where aquatic conditions consist of marine waters from Elliott Bay transitioning with freshwater from the Green-Duwamish River.

The LDW is used as an industrial and commercial corridor, consistent with the land use, zoning, and land ownership in the LDW. The LDW is also part of Tribal U&A fishing areas. The Muckleshoot Indian Tribe currently conducts seasonal netfishing operations in the LDW for commercial, ceremonial, and subsistence purposes. The Suquamish Tribe actively manages resources north (downstream) of the Spokane Street Bridge, located just north of the LDW (EPA 2014). The Duwamish Tribe uses Herring’s House Park and other parks along the Duwamish for cultural gatherings.

As described in Section 3 and depicted in Figure E3-1, the action area lies between the boundary of Elliott Bay and RM 5.2 of the LDW, which is largely an industrial/commercial area and also includes the South Park residential neighborhood. The action area and much of the neighboring properties were constructed primarily on fill from dredged material when the LDW was straightened during the early 1900s. Most of the significant adverse effects of the proposed action are expected to occur within the RAAs, which are contaminated areas within the upper reach (i.e., between RMs 3 and 5) where active remediation will occur. As such, the following subsections provide detailed

environmental baseline information for the upper reach of the LDW. Existing conditions within the upper reach range from highly modified to natural habitat conditions, as shown in Figures E2-2a and E2-2b. Habitat conditions within the RAAs only are shown in Figures E4-1a and E4-1b, and photographs of the RAAs that overlap with intertidal areas are shown in Attachment E.1. These conditions are described in more detail in the following subsections.

4.1 Biological Habitat Conditions

Although highly modified, the upper reach of the LDW provides some habitat for salmon and other fish, birds, mammals, and other wildlife. As part of the Water Resource Inventory Area (WRIA) 9 strategy to improve salmonid habitat throughout the watershed, several restoration projects have been completed within the upper reach to restore shallow water habitat, shoreline bank, and riparian buffer (WRIA 9 2015). Existing habitat restoration projects that have been completed include the following:

- The King County shoreline habitat restoration project between RMs 3.3W and 3.4W, which includes restoration of 300 linear feet of upland and intertidal habitat
- The Boeing Plant 2 South Site habitat project between RMs 3.3E and 3.6E, which includes 1.2 acres of restored marsh habitat, 0.95 acre of restored riparian habitat, and 0.69 acre of restored intertidal habitat
- The Duwamish River People's Park and Shoreline Habitat project between RMs 3.5W and 3.9W (formerly Terminal 117 [T-117]), which restored 14 acres of native riparian buffer, intertidal marsh, intertidal shoreline, and subtidal habitat
- The Hamm Creek habitat area located at RM 4.3W, where 1 acre of emergent salt marsh, 2 acres of freshwater wetlands, and nearly 2,000 feet of the Hamm Creek streambed have been restored
- The Muckleshoot Tribe habitat area at Kenco Marine, which is located near the Turning Basin at RM 4.6W, where 0.43 acre of emergent marsh and intertidal habitat and 0.23 acre of riparian habitat have been restored
- Multiple restoration projects within the Turning Basin (RM 4.7W) that have included derelict vessel removal, fill removal, creosote-treated piling and derelict structure removal, fill and large woody debris placement, and riparian and emergent plantings, resulting in 5 acres of restored intertidal habitat from 1996 through 2007 (Seaport Planning Group 2009)

Existing biological habitat conditions related to riparian habitat and large woody debris and in-channel habitat within the upper reach are described in the following sections.

4.1.1 Riparian Habitat and Large Woody Debris

A visual inspection of shoreline vegetation along the upper reach of the LDW was conducted by boat as part of the PDI Phases I and II in 2020 and 2021. As part of this data collection effort, vegetation

conditions along the riverbank in the entire upper reach were documented via visual inspection. Vegetation was documented along riverbank stations, including vegetation type, percent cover, and plant communities. Conditions were documented for top of bank (above MHHW in the riparian zone), mid-bank (below MHHW in the intertidal zone), and toe of slope (area below bank observed during the low-tide inspections in the intertidal zone). Appendix I of the *Final Pre-Design Investigation Data Evaluation Report for the Lower Duwamish Waterway Upper Reach* (Anchor QEA and Windward 2022) is provided as Attachment E.5 of this BA and includes the results of the visual inspection of shoreline vegetation that document a range of vegetation conditions.

Overall, the bank vegetation within the upper reach consists of a mix of native trees, landscaping trees, native shrubs, and non-native shrubs in limited layers. The Phase I and II shoreline vegetation information was mapped using polygons and classified as “vegetated buffer – native species,” “vegetated buffer – non-native species,” and “degraded vegetated buffer.” Degraded vegetated buffer includes vegetation that occurs adjacent to a bulkhead or within or adjacent to an armored slope. These vegetation conditions are shown in Figures E2-2a and E2-2b. Vegetation along the shoreline consists of three major plant communities: trees, shrubs, and grasses/ferns/herbaceous. The trees are dominated by native species such as red alder (*Alnus rubra*), madrone (*Arbutus menziesii*), and black cottonwood (*Populus balsamifera* ssp. *trichocarpa*). Shrubs and herbaceous plants are dominated by non-native species such as butterfly bush, Himalayan blackberry, Scotch broom (*Cytisus scoparius*), yellow-flag iris (*Iris pseudacorus*), English ivy (*Hedera helix*), and field bindweed (*Convolvulus arvensis*). From RMs 3.3 to 3.6 (Boeing Plant 2 South Site habitat project) on the east bank and RMs 3.3 to 3.4 (King County shoreline habitat restoration project), RMs 3.5 to 3.9 (Duwamish River People’s Park and Shoreline Habitat project), RM 4.3 to 4.4 (Hamm Creek), and RMs 4.6 to 4.7 (Turning Basin restoration projects) on the west bank, mitigation and landscape plantings can be found, including more native species such as Douglas fir (*Pseudotsuga menziesii*), oceanspray (*Holodiscus discolor*), Nootka rose (*Rosa nutkana*), and red elderberry (*Sambucus racemosa*).

Large woody debris was identified along the Boeing shoreline between RMs 3.3 and 3.6 and along the habitat restoration project areas between RMs 3.5 to 3.9 (Duwamish River People’s Park and Shoreline Habitat project), and RMs 4.3 to 4.4 (Hamm Creek). This large wood was placed as part of a habitat restoration project and did not naturally accumulate in these areas. These observations on large woody debris from the visual survey are consistent, with a survey conducted in 2013 by the WRIA 9 Coordination Team. The habitat survey included a reach of the Duwamish River that extended from the mouth to RM 5.5 and identified 91 pieces of large woody debris, of which 63% were placed as part of restoration projects (R2 2014). Of the three observed debris jams, two were in conjunction with the revetment along Portland Street at RM 2.8, downstream of the project area (R2 2014). Large woody debris along riverine and estuarine shorelines contributes to juvenile salmon growth and survival by increasing habitat complexity, creating refuge habitat, and providing a substrate for primary producers (Bisson et al. 1987; Sedell et al. 1988). In the upper reach portion of

the action area, large woody debris is mostly absent due to the lack of woody debris sources except in the areas noted previously.

Intact riparian habitat has well-developed vegetation, usually with multiple canopy layers, and each layer consists of unique habitats that support a diversity of species (Knutson and Naef 1997). Although most of the riparian habitat within the upper reach is degraded, there are areas with higher functioning riparian habitat, including the Boeing habitat restoration areas that include off-channel habitat, riparian vegetation, and large woody debris between RMs 2.9 and 3.0 and RMs 3.3 and 3.6; an area near Hamm Creek at RM 4.3; and an area in the Turning Basin near RAA 30 near RM 4.7. Riparian habitat performs many functions important for salmon, steelhead, and bull trout survival and productivity. Vegetation in riparian areas provides shade and cool temperatures needed by most fish. Plant roots stabilize streambanks and control erosion and sedimentation, and vegetation creates overhanging cover for fish. Riparian habitat contributes leaves, twigs, and insects to adjacent rivers, providing food and nutrients that support fish and aquatic wildlife. Large trees in riparian areas fall into streams and create a variety of habitat types that are necessary for fish to use as cover, spawning, rearing, and protection from predators (Knutson and Naef 1997). Riparian vegetation, litter layers, and soils filter incoming sediments and pollutants, thereby assisting in the maintenance of high water quality needed for healthy fish populations. Riparian habitat moderates stream volumes by reducing peak flows during flooding periods and by storing and slowly releasing water into streams during low flows. Due to the degraded condition of a majority of the riparian areas in the upper reach, these riparian functions are not fully provided.

4.1.2 *In-Channel Habitat*

In-channel habitat for aquatic species and aquatic-dependent species exists in the LDW and extends from the waterward edge of the riparian zone above the elevation of MHHW (+11.3 feet MLLW) down to the deep subtidal areas of the LDW. These areas are all considered habitat and are divided into the following habitat types based on elevation (NOAA 2002, 2013; EPA 2014):

- **Deep Subtidal:** Deeper than -10 feet MLLW
- **Shallow Subtidal:** -10 feet MLLW to -4 feet MLLW
- **Lower Intertidal:** -4 feet MLLW to +4 feet MLLW
- **Upper Intertidal:** +4 feet MLLW to +11.3 feet MLLW

These existing habitat types and conditions are shown in Figures E2-2a and E2-2b. Degraded habitat types are defined as areas that contain an overwater structure, riprap/debris, and/or are adjacent to a bulkhead wall.

Remedial Investigation (RI) Section 2.8 and FS Section 2.1.5 (Windward 2010; AECOM 2012) summarize the habitat types in the entire LDW. The habitat types in the LDW include intertidal marshes, intertidal mudflats, sloped and armored intertidal areas, and subtidal areas. Intermittent,

shallow benches exist in the intertidal and shallow subtidal zones of the LDW, outside the navigation channel. These benches are of various dimensions and elevations, with minimum elevations of less than 3 feet MLLW. Intertidal marshes contain marsh soils (generally fine-textured and nutrient-rich), supporting grasses, sedges, rushes, and various other plants. For example, the Hamm Creek and Turning Basin restoration areas contain intertidal marshes within the upper reach.

Intertidal mudflats are generally defined as the gently sloping areas from MLLW up to the edge of intertidal marsh vegetation (Blomberg et al. 1988). They are unvegetated with sand or silt substrate and represent most of the intertidal area within the upper reach. With the highly altered condition of the LDW, intertidal mudflats between -4 and +12 feet MLLW were identified as the habitat feature most needed to support salmonid life-history stages in the LDW below RM 5.5 (Ostergaard et al. 2014).

Shallow water habitats having gentle intertidal gradients and lower velocities tended to support higher Chinook salmon densities in a juvenile Chinook salmon study conducted in the LDW (Ruggerone et al. 2005). Additional studies outside of the LDW also found shallow water (i.e., less than 6.5 feet deep) to be important for the growth and survival of juvenile salmon, especially subyearling Chinook salmon, because these areas tend to have low velocities and a shallow slope and are close to shoreline riparian areas (Tiffan et al. 2006; NMFS 2005; Fresh 2006; Everest and Chapman 1972; Hillman et al. 1987; Johnson et al. 1992). Six to ten feet of water depth is also important for juvenile salmon for rearing and migration because juvenile fish are expected to move to deeper water as they grow. The Oregon Department of Fish and Wildlife (ODFW 2005) found that sites with an average depth between 2.1 and 3.0 meters (7 to 10 feet) had significantly higher catch per unit of effort of Chinook salmon than deeper sites. At low water, the -10-foot-MLLW and shallower habitat range will provide 0 to 10 feet of water depth. Up to 10 feet of water depth is important not only for meeting juvenile salmon habitat requirements but also for supporting all aquatic species. Between 2005 and 2014, approximately 5.8 acres of shallow water habitat has been restored along the LDW, representing a large improvement but falling short of the WRIA 9 Salmon Habitat Plan goal of 26.5 acres (WRIA 9 2015). The addition of approximately 6.7 acres of intertidal and emergent marsh habitat from the Duwamish River People's Park and Shoreline Habitat project brings that total to approximately 12.5 acres.

Nearshore shallow water habitat is the most biologically productive zone of a large estuarine river. This productivity is important in providing a food base for aquatic species throughout the LDW. Intertidal marsh habitat provides refuge as well as foraging and rearing habitat for benthic invertebrates and fish, including juvenile salmonids (Battelle et al. 2001). In addition, intertidal marshes provide important foraging and rearing habitat for many bird species, including great blue heron, killdeer, and marsh wrens. Intertidal mudflats serve as sources of nutrients for primary producers and provide food and habitat for benthic invertebrates, fish, shorebirds, and aquatic mammals (Battelle et al. 2001). Clams are also present in intertidal habitats in the LDW (Windward 2004).

Approximately 48 acres of the upper reach were identified in the ROD as potential clamming areas based on bathymetric elevations (i.e., shallower than -4 feet MLLW) (EPA 2014). However, substrate and salinity conditions within the elevation band should also be considered when identifying potential clamming areas. For example, areas above RM 4.8 do not have sufficient saline conditions for clams. Potential clamming areas are a subset of the intertidal areas.

Overall, the upper intertidal, intertidal, and shallow subtidal habitat types defined for the LDW (i.e., areas shallower than -10 feet MLLW) include the most valuable intertidal habitat types within the LDW and include the water depth band that has been shown to be the most important for juvenile salmon, particularly Chinook salmon, and other aquatic and semiaquatic species, including benthic invertebrates (e.g., clams), fish, and shorebirds. Overall, no changes in acreages are expected for any habitat type. A full habitat evaluation was conducted, as described in Attachment E.6.

4.2 Physical Conditions

Infrastructure along the LDW within the action area includes waterfront facility berthing, overwater structures (e.g., piers, docks, floats, bridges, flow diversion structures, and covered boat slips), piling (e.g., erosion control structures, fendering, and mooring piles), bridges, and utilities (e.g., underwater cables and pipe structures, overwater cables, storm drains, and outfalls). The shoreline of the action area is armored with rock riprap and intermittent concrete, steel sheetpile, and timber walls and bulkheads. These physical conditions have degraded the habitat available for listed steelhead, salmon, and bull trout, as described in the following subsections.

4.2.1 Shoreline Armoring

The shoreline of the action area includes armor with rock riprap and intermittent concrete, steel sheetpile, and timber walls and bulkheads. Figure E4-2 shows the shoreline condition throughout the upper reach. Note that “unarmored shoreline” is defined from an engineering perspective as banks that have no armoring, discontinuous armoring, anthropogenic debris, or poorly placed and maintained armoring. Based on the shoreline condition shown in Figure E4-2, approximately 41% of the upper reach bank areas are armored, 46% are unarmored, and 13% are bulkheaded. However, the unarmored category contains conditions that are considered armored from a non-engineering perspective.

The armoring and channelizing that has occurred within the action area has largely disconnected the LDW upper reach from its floodplain. As a result of development within the floodplain and riparian areas, the action area lacks woody debris sources.

4.2.2 Substrate and Slope

The dominant substrate size ranges from large angular rock, debris, and riprap near the shore grading to sand and silt in the lower intertidal and shallow subtidal zone. As the shoreline levels out

from the bank, a mudflat is exposed at low tide. The bank slope is generally steep where the large angular rock, debris, and riprap have been placed and then flattens out to a shallower slope as the steep shoreline grades into a mudflat.

Grain size throughout the upper reach was evaluated during Phase I of the PDI (Anchor QEA and Windward 2022). Grain size testing was completed on 262 surface and subsurface sediment samples using the 1986 grain size method from the Puget Sound Estuary Program. In general, grain size data indicated that surface (0- to 10-cm) and subsurface (0- to 45-cm and 0- to 60-cm) samples are predominantly sand and silt, with varying gravel and clay compositions. Specific percentage ranges of gravel, sand, silt, and clay detected in Phase I samples analyzed for grain size were as follows:

- **Gravel:** 0% to 38%
- **Sand:** 4% to 99%
- **Silt:** 4% to 80%
- **Clay:** 1% to 26%

4.2.3 *Overwater and In-Water Structures*

As part of the Phase I and Phase II PDI, structures, including overwater structures (e.g., wharves, piers, docks), in-water structures (e.g., piles, pile groups, dolphins), and shoreline structures and utilities (e.g., outfalls, bulkheads, wing walls) were documented. These structures are shown in Figure E4-2.

The effect of these artificial structures, particularly overwater structures, on outmigrating juvenile salmonids is not well understood. Some studies suggest that overwater structures have the potential to affect juvenile salmonids through habitat changes, increased predation, and disruption of migration patterns (see Lambert et al. 2021 for a review). These studies have not yielded conclusive results. Multiple studies suggest that the movement of juvenile salmonids may be affected by dark/light interfaces cast by overwater structure (Nightingale and Simenstad 2001; NMFS 2004a; Southard et al. 2006). Studies have shown that juvenile salmonids may follow the edge of a shadow along piers, rather than pass under the pier. The Pacific Northwest National Laboratory (PNNL) conducted a study at 10 Washington State Ferries terminals and found that overwater structures are likely temporary impediments to the movement of juvenile salmonids during specific times of the day or under specific environmental conditions. The specifics depend on light levels, sun angles, and cloud cover, as well as currents and tidal stage. Additionally, the study found that “juvenile chum remained on the light side of a dark/light shadow line when the decrease in light level was approximately 85 percent over a shore horizontal distance (e.g., 16.4 feet [5 m])” (Southard et al. 2006). However, in a separate study conducted by PNNL at the existing Mukilteo Ferry Terminal, “salmon fry moved freely under the relatively narrow, shaded portion of the Mukilteo Ferry Terminal where mean light levels in water were reduced by over 97%” (Williams et al. 2003). Observers concluded that “during the day, fry moved freely under the relatively narrow (33 feet [10 m] wide),

shaded portion of the ferry terminal and did not appear to be inhibited by the differences in light levels detected here [...] the terminal structure did not appear to act as barriers to fry movement at this location" (Williams et al. 2003).

WRIA 9 identifies the removal of overwater structures as a priority restoration action, particularly in the nearshore marine environment where overwater structures also impact forage fish (WRIA 9 2021). Although it is unclear if artificial structures in the aquatic environment act as an obstruction to migration by causing migration delays, it is expected that potential delays are minimal and are unlikely to impact the overall migration rate of juvenile or adult salmonids migrating through the upper reach.

4.3 Chemical Conditions

4.3.1 Water Quality

The upper reach is an estuary environment, with freshwater entering from the Green-Duwamish river system and saltwater originating from Puget Sound. The location of the interface between freshwater and marine layer flows, referred to as the saltwater wedge, is variable within the upper reach depending upon both river flow and tidal stage. During times of high river flow and low-tide stages, the saltwater wedge does not enter the upper reach, whereas during low-flow conditions and high tide stages, the saltwater wedge can extend upstream of the upper reach. The upstream location or "toe" of the saltwater wedge is typically located between Slip 4 (RM 2.8) and the Turning Basin (RM 4.7).

The most recent Washington State Water Quality Assessment identifies locations throughout the LDW and Duwamish River that are impaired based on CWA Section 303(d) criteria (Ecology 2022a). The waters in the vicinity of the action area are listed as Category 5 waters for tissue, temperature, bacteria (fecal coliform and enterococci), and DO (Ecology 2022b). Category 5 is defined as "polluted water that requires a water quality improvement project" (Ecology 2022a). Baseline water chemistry data that measured PCBs, dioxins/furans, PAHs, metals, and other chemicals showed priority pollutants below aquatic life water quality criteria (Table E4-1; Windward 2020).

**Table E4-1
Baseline Water Chemistry Data for the LDW and Upstream Area (Windward 2020)**

Chemical ¹	Fraction	LDW Summary Statistics				Upstream Summary Statistics				National Recommended Criteria		Washington State Criteria ²	
		Detection Frequency		Mean Value	Range of Detected Concentrations	Detection Frequency		Mean Value	Range of Detected Concentrations	AWQC – Marine		Marine	
		Ratio	%			Ratio	%			CMC (acute)	CCC (chronic)	Acute	Chronic
Metals (µg/L)													
Arsenic	D	20/20	100	1.32	0.602 J–2.06	5/5	100	0.641	0.453–0.904	69	36	69	36
Cadmium	D	3/20	15	0.23	0.023 J–0.123 J	0/5	0	0.010	ND	33	7.9	42	9.3
Chromium	D	2/20	10	0.925	0.651 J–0.668 J	3/5	60	0.126	0.120–0.190	1,100	50	1,100	50
Copper	D	29/32	91	0.955	0.573 J–2.32	8/8	100	0.555	0.279–1.20	4.8	3.1	4.8	3.1
Lead	D	0/20	0	0.192	ND	5/5	100	0.0786	0.0450–0.121	210	8.1	210.0	8.1
Nickel	D	14/20	70	0.876	0.404 J–1.42 J	5/5	100	0.248	0.165–0.329	74	8.2	74.0	8.2
Selenium	D	0/20	0	0.715	ND	4/5	80	0.034	0.023 J–0.047 J	290	71	290	71.0
Silver	D	0/20	0	0.268	ND	0/5	0	0.011	ND	1.9	--	1.9	--
Zinc	D	15/20	75	4.04	1.71 J–6.73 J	4/5	80	3.31	1.66–6.50	90	81	90	81
Mercury (ng/L)													
Mercury	T	15/20	75	1.4	0.76–4.17	3/5	60	1.4	0.81–2.62	1,800	940	1,800	25
Semivolatile Organic Compounds (ng/L)													
Pentachlorophenol	T	0/12	0	5.00	ND	0/3	0	5.00	ND	13	7.9	13	7.9
Total PCBs (ng/L)													
Total PCB Congeners	T	32/32	100	1.060	0.02172 J–4.942 J	8/8	100	0.0739	0.01052 J–0.2289 J	--	30	10,000	30

Notes:

--: No existing criterion

1. Chemical list has been reduced to only chemicals that are LDW COCs and have water quality criteria. The full list of chemicals that were analyzed is provided in the *Lower Duwamish Waterway Pre-Design Studies Data Evaluation Report* (Windward 2020).
2. Washington State Criteria include standards promulgated in WAC 173-201A.

AWQC: ambient water quality criteria

µg/L: microgram per liter

CCC: criterion continuous concentration

CMC: criterion maximum concentration

COC: contaminant of concern

D: dissolved fraction

J: estimated concentration

LDW: Lower Duwamish Waterway

nd: not detected

ng/L: nanogram per liter

PCB: polychlorinated biphenyl

T: total fraction (unfiltered)

WAC: Washington Administrative Code

Upper reach sediment is a known contaminant source that can potentially impact surface water quality through diffusion and advection of porewater containing dissolved chemicals. Mechanical disturbances to sediment from propeller wash (propwash) or in-water construction and natural erosion and transport may also result in releases to the water column. Potential contaminant effects on listed fish species and other aquatic receptors as a result of sediment resuspension because of a disturbance of the substrate are a function of the chemical, its concentration within the sediment, the environmental conditions at the time of the disturbance, and the duration of exposure. Contaminants become mobilized during sediment disturbance through the release of porewater containing dissolved chemicals, by desorption from sediment, and through loss of particulate-bound contaminants (Averett et al. 1999). Once mobilized, metal contaminants are mostly bioavailable when in a dissolved phase, whereas organic contaminants can be bioavailable in both dissolved and particulate-bound phases (Eggleton and Thomas 2004).

4.3.2 Sediment Quality

Sediment quality has been extensively evaluated in the LDW, including the upper reach. The LDW was added to EPA's National Priorities List in 2001 and to the Washington State Hazardous Sites List in 2002. The LDWG completed the LDW RI in 2010, which included assessment of risks to human health and the environment (Windward 2010) and the LDW FS in 2012 (AECOM 2012) to evaluate cleanup alternatives. EPA identified the selected cleanup remedy in the ROD released in November 2014 (EPA 2014) and the cPAH ESD (EPA 2021).

Based on the LDW Superfund Site Baseline Ecological Risk Assessment (BERA) presented in the RI (Windward 2010), the sediment-associated contaminants of potential concern (COPC) for juvenile Chinook salmon included arsenic, cadmium, copper, and vanadium. The pathways of exposure for juvenile Chinook salmon included direct water contact and ingestion of benthic prey species and ingestion of other organisms (e.g., zooplankton, terrestrial insects). Assessment endpoints included growth and survival. Overall, risks to juvenile Chinook salmon from these sediment associated COPCs were found to be low and uncertain. Because juvenile Chinook salmon were used as a surrogate species in the BERA, similar low risks from sediment associated COPCs were assumed for other salmonid species, including steelhead and bull trout.

5 Species and Critical Habitats Potentially Present in Action Area

This section provides species and critical habitat information and presence in the action area. The ESA-listed fish that could be present in the action area include Puget Sound Chinook salmon, Puget Sound steelhead, Coastal-Puget Sound bull trout, Puget Sound/Georgia Basin yelloweye rockfish, Puget Sound/Georgia Basin bocaccio, and Southern Resident killer whales (NMFS 2022; USFWS 2022a). Other listed and proposed endangered and threatened species that could potentially occur in the vicinity of the action area include sunflower sea star (88 Federal Register [FR] 16212, March 16, 2023), marbled murrelet, Western yellow-billed cuckoo, and North American wolverine (USFWS 2022a). However, as discussed in Sections 5.9 and 5.10, suitable habitat for Western yellow-billed cuckoo and North American wolverine does not exist within or near the action area. As such, these species will not be evaluated in Section 6.

5.1 Chinook Salmon Puget Sound Evolutionarily Significant Unit

The Puget Sound Chinook salmon evolutionarily significant unit (ESU) was listed as threatened on March 24, 1999, and revised on June 28, 2005, and April 14, 2014 (64 FR 14308; 70 FR 37159; 79 FR 20802). Critical habitat was designated on September 2, 2005 (70 FR 52698), and includes the portions of the Duwamish Waterway within the LDW Superfund Site. The Puget Sound ESU includes naturally spawned Chinook salmon originating from rivers flowing into the Puget Sound from the Elwha River eastward, including rivers in Hood Canal, South Sound, North Sound, and the Strait of Georgia, as well as from 25 different hatchery programs within the Puget Sound region (NOAA 2022a). The Green River Chinook salmon population is one of six Chinook salmon populations in the Central/South subbasin and one of twenty-two remaining populations in the Puget Sound Chinook salmon ESU (King County 2021).

Chinook salmon are often found in waterbodies that are in undisturbed areas that contain cold water, with clean spawning and rearing gravel and habitat complexity. Puget Sound ESU Chinook salmon exhibit a stream-type life-history strategy, meaning that juvenile Chinook salmon typically rear in freshwater for 1 year prior to emigrating to the ocean as yearling smolts. Some proportion of naturally spawned Chinook salmon juveniles (not produced in a hatchery) move relatively short distances downstream out of natal tributaries during the late summer through winter of their first year. Chinook salmon typically enter the Green-Duwamish river system between July and October depending on seasonal water temperature and flow, with the majority of spawning occurring in mid-September and October in the upper parts of the watershed (King County 2021).

The recent 5-year status review of Puget Sound Chinook salmon indicated that although population abundance has been highly variable since the 1980s, there appears to be an overall decline in most wild spawning populations in recent years, and viability is generally unchanged from the 2015 review

(Ford 2022). The Puget Sound Chinook salmon ESU remains at moderate risk of extinction. This ESU continues to face habitat constraints as a result of many human interventions in the watershed, including increasing urbanization.

5.1.1 *Critical Habitat Presence in the Action Area*

Critical habitat for Puget Sound Chinook salmon was designated on September 2, 2005 (70 FR 52629), and became effective on January 2, 2006. In freshwater zones, the lateral extent of critical habitat is defined as the ordinary high water mark (OHWM). In estuarine and nearshore marine areas, critical habitat includes areas contiguous with the shoreline from the line of extreme high water out to a depth no greater than 30 meters relative to MLLW. Within the action area, estuarine critical habitat is present from the furthest downstream reach up to RM 3.1 according to NMFS maps, and freshwater critical habitat begins at the 102nd Street bridge, at RM 5.0, and extends upstream (NMFS 2022, 2023; 70 FR 52698). Based on currently available NMFS maps, there appears to be a gap in the critical habitat within the action area from RM 3.1 to RM 5.0. It is unclear whether the definition in the Federal Register and currently available maps from NMFS inconsistently describe the upstream extents of estuarine critical habitat. Regardless, both types of critical habitat are present within the action area and analyzed as part of this project, even if there is a gap.

The designation of critical habitat is based on the life history and habitat needs of Puget Sound Chinook salmon and includes six physical or biological features (PBFs) necessary for their conservation in freshwater, estuarine, and nearshore marine habitats. In the action area, PBFs 2, 3, and 4 are present, as detailed in Table E5-1. PBFs 2 and 3 have minimal overlap with the action area and are degraded by the lack of floodplain connectivity, natural cover, aquatic vegetation, and habitat features to support juvenile growth, refugia, and mobility. PBF 4, which comprises most of the action area as it extends to Elliott Bay, is degraded by the impaired water quality and limited presence of natural cover and habitat features that would support growth and maturation.

**Table E5-1
Puget Sound Chinook Salmon ESU Critical Habitat PBFs Within the Lower Duwamish Waterway**

Physical and Biological Habitat Features	Status
PBF 1: Freshwater spawning sites with water quantity and quality conditions and substrate supporting spawning, incubation and larval development. These features are essential to conservation because without them the species cannot successfully spawn and produce offspring.	PBF not present.
PBF 2: Freshwater rearing sites with water quantity and floodplain connectivity to form; maintain physical habitat conditions and support juvenile growth and mobility; water quality and forage supporting juvenile development; natural cover such as shade, submerged and overhanging large wood, log jams and beaver dams, aquatic vegetation, large rocks and boulders, side channels, and undercut banks. These features are essential to conservation because without them juveniles cannot access and use the areas needed to forage, grow, and develop behaviors (e.g., predator avoidance, competition) that help ensure their survival.	PBF present above RM 5.0, but functioning in limited capacity.
PBF 3: Freshwater migration corridors free of obstruction with water quantity and quality conditions and natural cover such as submerged and overhanging large wood, aquatic vegetation, large rocks and boulders, side channels, and undercut banks supporting juvenile and adult mobility and survival. These features are essential to conservation because without them juveniles cannot use the variety of habitats that allow them to avoid high flows, avoid predators, successfully compete, begin the behavioral and physiological changes needed for life in the ocean, and reach the ocean in a timely manner. Similarly, these features are essential for adults because they allow fish in a non-feeding condition to successfully swim upstream, avoid predators, and reach spawning areas on limited energy stores.	PBF present above RM 5.0, but functioning in limited capacity.
PBF 4: Estuarine areas free of obstruction with water quality, water quantity, and salinity conditions supporting juvenile and adult physiological transitions between fresh and saltwater; natural cover such as submerged and overhanging wood, aquatic vegetation, large rocks and boulders, and side channels; and juvenile and adult forage, including aquatic invertebrates and fishes, supporting growth and maturation	PBF present but functioning in limited capacity.
PBF 5: Nearshore marine areas free of obstruction with water quality and quantity conditions and forage, including aquatic invertebrates and fishes, supporting growth and maturation, and natural cover such as submerged and overhanging large wood, aquatic vegetation, large rocks and boulders, and side channels	PBF not present.
PBF 6: Offshore marine areas with water quality conditions and forage, including aquatic invertebrates and fishes, supporting growth and maturation	PBF not present.

Notes:

ESU: evolutionarily significant unit

PBF: physical or biological feature

RM: river mile

5.1.2 Utilization of the Action Area

Juvenile Chinook salmon use the action area for rearing and migration and can typically be found within the Duwamish River estuary between February and July, although presence in the Duwamish River estuary was documented as early as December (Ruggerone et al. 2006). Residence time in the estuary can vary significantly, with some fish spending days and other fish spending weeks to months

rearing in the transition zone (King County 2021). Juvenile salmon rely on shallow and low-gradient habitat to forage and grow, and the extensive industrial development along the LDW has resulted in severe habitat loss. Without the high-quality estuarine habitat that juvenile salmon need, fish may be more likely to migrate downstream on an accelerated timeline and have a lower chance of survival once they enter Puget Sound (King County 2021). PCB levels in wild fish have been shown to be significantly higher than in their hatchery counterparts, suggesting that wild Chinook salmon spend more time within the Duwamish estuary (King County 2021). By examining 37 years of hatchery data from 20 hatcheries across 14 watersheds, it was found that there is a 45% lower smolt-to-adult survival rate for hatchery-origin Chinook salmon that migrate through contaminated estuaries compared to uncontaminated estuaries, and because natural-origin Chinook spend more time in the estuary, their declined survival may be even more pronounced (King County 2021). Additionally, Chinook salmon that enter the Duwamish as fry experience very low survival compared to the parr outmigrants (King County 2021). Adult Chinook salmon use the action area on their migration back to their natal streams. This occurs in late June into early November, with large numbers entering the river by July (Williams et al. 1975; Frissell et al. 2000; Kerwin and Nelson 2000), and with many early immigrating Chinook salmon holding in the lower Duwamish and Green rivers (Duwamish to Kent area) until approximately mid-September (Ruggerone and Weitkamp 2004; Ruggerone et al. 2006). Chinook salmon spawning is not known to occur in the LDW or in the streams flowing into the estuary and lower reaches of the waterway (Weitkamp and Ruggerone 2000).

5.2 Steelhead Puget Sound Distinct Population Segment

Puget Sound steelhead were listed as threatened on May 11, 2007 (72 FR 26722), and updated on April 14, 2014 (79 FR 20802). Critical habitat was finalized on February 24, 2016 (81 FR 9252). The Puget Sound distinct population segment (DPS) includes naturally spawned anadromous steelhead originating below natural and human-made impassable barriers from rivers flowing into Puget Sound from the Elwha River eastward, including rivers in Hood Canal, South Sound, North Sound, and the Strait of Georgia, as well as from five different hatchery programs within the Puget Sound region (NOAA 2022b).

Steelhead are often found in waterbodies that are in undisturbed areas that contain cold water, with clean spawning and rearing gravel and habitat complexity. Steelhead are anadromous salmonids that, unlike most other Pacific salmon, are iteroparous (i.e., they can spawn several times), with spawning starting in their fourth or fifth year and continuing until reaching a maximum age of approximately 11 years (Busby et al. 1996). Puget Sound steelhead smolts tend to migrate to the ocean to mature after spending 2 years in freshwater (Hard et al. 2007). Both winter- and summer-run steelhead can be found within the Duwamish Waterway (SWIFD 2022). Winter steelhead are more common within Puget Sound and typically return to Puget Sound tributaries from December to April, with spawning occurring from January to mid-June (Myers et al. 2015). There are

two winter steelhead stocks in this basin: a native population and a hatchery stock. Summer steelhead generally return to the rivers from May to October, with spawning occurring from January to April (Myers et al. 2015). The summer steelhead stock is of hatchery origin (WDFW 2011).

The recent NMFS 5-year status review showed an increasing viability trend of the Puget Sound steelhead DPS populations (Ford 2022). This DPS continues to face habitat constraints as a result of many human interventions in the watershed, including increasing urbanization. The potential for extinction of steelhead in Central Puget Sound remains moderate.

5.2.1 Critical Habitat Presence in the Action Area

The final rules designating critical habitat for Puget Sound steelhead was published on February 24, 2016 (81 FR 9252). This designation includes the Puget Sound DPS of steelhead. In freshwater zones, the lateral extent of critical habitat is defined as the OHWM and begins at RM 5.0. Downstream of RM 5.0 is considered estuarine area, and steelhead critical habitat is mapped through the entire waterway downstream to Elliott Bay.

The designation of critical habitat is based on the life history and habitat needs of Puget Sound steelhead and includes six PBFs necessary for their conservation in freshwater, estuarine, and nearshore marine habitats. In the action area, PBFs 2, 3 and 4 are present, as detailed in Table E5-2. PBFs 2 and 3 have minimal overlap with the action area and are degraded by the lack of floodplain connectivity, natural cover, aquatic vegetation, and habitat features to support juvenile growth, refugia, and mobility. PBF 4, which comprises most of the action area, is degraded by the impaired water quality and limited presence of natural cover and habitat features that would support growth and maturation.

**Table E5-2
Puget Sound Steelhead DPS Critical Habitat PBFs within the Lower Duwamish Waterway**

Physical and Biological Habitat Features	Status
PBF 1: Freshwater spawning sites with water quantity and quality conditions and substrate supporting spawning, incubation and larval development. These features are essential to conservation because without them the species cannot successfully spawn and produce offspring.	PBF not present.
PBF 2: Freshwater rearing sites with water quantity and floodplain connectivity to form; maintain physical habitat conditions and support juvenile growth and mobility; water quality and forage supporting juvenile development; natural cover such as shade, submerged and overhanging large wood, log jams and beaver dams, aquatic vegetation, large rocks and boulders, side channels, and undercut banks. These features are essential to conservation because without them juveniles cannot access and use the areas needed to forage, grow, and develop behaviors (e.g., predator avoidance, competition) that help ensure their survival.	PBF present above RM 5.0, but functioning in limited capacity.
PBF 3: Freshwater migration corridors free of obstruction with water quantity and quality conditions and natural cover such as submerged and overhanging large wood, aquatic vegetation, large rocks and boulders, side channels, and undercut banks supporting juvenile	PBF present above RM 5.0, but functioning

Physical and Biological Habitat Features	Status
and adult mobility and survival. These features are essential to conservation because without them juveniles cannot use the variety of habitats that allow them to avoid high flows, avoid predators, successfully compete, begin the behavioral and physiological changes needed for life in the ocean, and reach the ocean in a timely manner. Similarly, these features are essential for adults because they allow fish in a non-feeding condition to successfully swim upstream, avoid predators, and reach spawning areas on limited energy stores.	in limited capacity.
PBF 4: Estuarine areas free of obstruction with water quality, water quantity, and salinity conditions supporting juvenile and adult physiological transitions between fresh and saltwater; natural cover such as submerged and overhanging wood, aquatic vegetation, large rocks and boulders, and side channels; and juvenile and adult forage, including aquatic invertebrates and fishes, supporting growth and maturation	PBF present but functioning in limited capacity.
PBF 5: Nearshore marine areas free of obstruction with water quality and quantity conditions and forage, including aquatic invertebrates and fishes, supporting growth and maturation; and natural cover such as submerged and overhanging large wood, aquatic vegetation, large rocks and boulders, and side channels	PBF not present.
PBF 6: Offshore marine areas with water quality conditions and forage, including aquatic invertebrates and fishes, supporting growth and maturation	PBF not present.

Notes:

DPS: distinct population segment

PBF: physical or biological feature

5.2.2 Utilization of the Action Area

Juvenile steelhead use the action area for rearing and migration. Juveniles typically remain in freshwater for 2 years on average before heading to sea. The seaward migration of steelhead juveniles mostly occurs from April to mid-May, which is the period when steelhead juveniles would be most likely found within the LDW. Smolts from the Green River averaged 153 millimeters (WDFW 2011). Green River steelhead smolts take approximately 2 weeks to exit the Duwamish River once downstream migration is begun, and acoustic tagging studies suggest that steelhead smolts migrate through estuaries quickly (WDFW 2011). Adult winter steelhead would be found migrating through the LDW on their way to their natal streams from December to April (Myers et al. 2015).

5.3 Coastal-Puget Sound Bull Trout

The coterminous U.S. population of bull trout was listed as threatened on November 1, 1999 (64 FR 58910), and critical habitat was finalized on October 18, 2010 (75 FR 63898). The Coastal-Puget Sound critical habitat includes the Green-Duwamish river system, including the action area.

Bull trout have specific cold-water requirements and are rarely found in waters with temperatures above 64°F (USFWS 2022b). They may also exhibit four different life-history types: anadromous, adfluvial, fluvial, and resident. Bull trout spawn from late summer through December, typically when water temperatures drop below 48°F (Wydoski and Whitney 2003). They reach sexual maturity in approximately 4 to 7 years, can live over 12 years, and are iteroparous, meaning that they can spawn

more than once in a lifetime. Their redds are typically found within streams that are sourced from cold groundwater and have low gradient. Fry can emerge from their eggs from early April through May. Juvenile bull trout feed on insects and then transition to small fish. Larger bull trout prey predominantly on fish. They are most prevalent in mountainous regions with snowmelt-dominant water and typically are found in deep pools of cold lakes and rivers with plenty of complex cover (USFWS 2022b).

5.3.1 Critical Habitat Presence in the Action Area

Critical habitat was designated in 2005 for the Coastal-Puget Sound population and expanded in 2010 based on the life history and habitat requirements of bull trout. According to the Coastal Recovery Unit Implementation Plan for Bull Trout, the two sub-units of bull trout critical habitat include spawning and rearing habitat and foraging, migration, and overwintering habitat (USFWS 2015). The action area is not part of a Coastal Recovery Unit Core Area. The lower Green-Duwamish river system is designated foraging, migration, and overwintering habitat in the action area (USFWS 2015). The action area overlaps bull trout critical habitat for spawning and rearing (USFWS 2022b).

Nine physical and biological features essential to the conservation of the species have been identified as essential for the conservation of bull trout and may require special management considerations or protection, as summarized in Table E5-3. In the action area PBFs 2, 3, 4, and 8 are present. The PBFs present in the action area are limited by the lack of riparian cover, reduced instream habitat features and habitat diversity, and existing water quality concerns.

Table E5-3
Bull Trout Critical Habitat PBFs Within the Lower Duwamish Waterway

Physical and Biological Habitat Features	Status
PBF 1: Springs, seeps, groundwater sources, and subsurface water connectivity (hyporheic flows) to contribute to water quality and quantity and provide thermal refugia	PBF not present.
PBF 2: Migration habitats with minimal physical, biological, or water quality impediments between spawning, rearing, overwintering, and freshwater and marine foraging habitats, including but not limited to permanent, partial, intermittent, or seasonal barriers	PBF present but functioning in limited capacity.
PBF 3: An abundant food base, including terrestrial organisms of riparian origin, aquatic macroinvertebrates, and forage fish	PBF present but functioning in limited capacity.
PBF 4: Complex river, stream, lake, reservoir, and marine shoreline aquatic environments, and processes that establish and maintain these aquatic environments, with features such as large wood, side channels, pools, undercut banks and unembedded substrates, to provide a variety of depths, gradients, velocities, and structure	PBF present but functioning in limited capacity.

Physical and Biological Habitat Features	Status
<p>PBF 5: Water temperatures ranging from 2°C to 15°C (36°F to 59°F), with adequate thermal refugia available for temperatures that exceed the upper end of this range. Specific temperatures within this range will depend on bull trout life-history stage and form; geography; elevation; diurnal and seasonal variation; shading, such as that provided by riparian habitat; streamflow; and local groundwater influence.</p>	<p>PBF not present because the LDW is designated as rearing and migration and the water quality standard is 17.5°C.</p>
<p>PBF 6: In spawning and rearing areas, substrate of sufficient amount, size, and composition to ensure success of egg and embryo overwinter survival, fry emergence, and young-of-the-year and juvenile survival. A minimal amount of fine sediment, generally ranging in size from silt to coarse sand, embedded in larger substrates, is characteristic of these conditions. The size and amounts of fine sediment suitable to bull trout will likely vary from system to system.</p>	<p>PBF not present.</p>
<p>PBF 7: A natural hydrograph, including peak, high, low, and base flows within historical and seasonal ranges or, if flows are controlled, minimal flow departure from a natural hydrograph</p>	<p>PBF not present.</p>
<p>PBF 8: Sufficient water quality and quantity such that normal reproduction, growth, and survival are not inhibited</p>	<p>PBF present but functioning in limited capacity.</p>
<p>PBF 9: Sufficiently low levels of occurrence of non-native predatory (e.g., lake trout, walleye, northern pike, smallmouth bass); interbreeding (e.g., brook trout); or competing (e.g., brown trout) species that, if present, are adequately temporally and spatially isolated from bull trout</p>	<p>PBF not present.</p>

Note:

PBF: physical or biological feature

5.3.2 Utilization of the Action Area

Bull trout are less common in the Duwamish River than in other Washington watersheds, but they have been documented foraging in the Duwamish River and LDW. One adult and zero juveniles were documented within the estuary in a 1995 study, but bull trout have been known to use Puget Sound, including the Duwamish River (King County 2001). Bull trout historically used the Duwamish River in great numbers, but with the construction of the ship canal and locks diverting flow from the Green-Duwamish river system, the watershed was greatly fragmented and diminished, lessening the quality and quantity of bull trout habitat. Bull trout have been reported in the lower Green River and presumably use the Green River up until the Headworks Diversion Dam at RM 61, a fish passage barrier (City of Seattle 2015). Bull trout were documented in the lower Duwamish River at the Turning Basin restoration site (RM 5.3) in 2000, 2002, and 2003, but none were captured during weekly beach seining from December 2004 to July 2005 (City of Seattle 2015). There is evidence that bull trout found in Puget Sound may originate from many different watersheds. In 2006, a tagged bull trout was observed in the Snohomish River, and a month later it was determined to be in the Duwamish River, where it stayed for a month before migrating back to the Snohomish River (USFWS 2017).

5.4 Puget Sound/Georgia Basin Yelloweye Rockfish Distinct Population Segment

The Puget Sound/Georgia Basin DPS of yelloweye rockfish was listed as threatened on April 28, 2010 (75 FR 22276). Critical habitat was designated on November 13, 2014 (79 FR 68042). Critical habitat includes Elliott Bay but does not extend into LDW or the action area.

Yelloweye rockfish are a large, long-lived rockfish most commonly occurring in deep water from 300 to 600 feet in depth (NMFS 2009). Rockfish are viviparous (i.e., their eggs are fertilized internally) and produce 1 million to 3 million larvae annually. The larvae are released in the spring and are distributed widely in surface water, floating with tides and currents. Juveniles use shallow waters and habitats including rocky reefs, kelp canopies, and structures such as piers and oil platforms. Juvenile yelloweye rockfish rarely occur in nearshore areas. Juveniles feed on zooplankton, including the larvae of crustaceans and invertebrates, as well as small fish. Adult yelloweye rockfish feed on many species of fish and larger invertebrates such as crabs and are more associated with rough rocky benthic habitats than bocaccio (NMFS 2017).

Yelloweye rockfish were recently sampled in low numbers in Puget Sound (NMFS 2017).

5.4.1 Critical Habitat Presence in the Action Area

Critical habitat includes deep water habitats. Critical habitat has been designated for deep water areas of Elliott Bay, but no critical habitat has been designated in the action area.

5.4.2 Utilization of the Action Area

Yelloweye rockfish are not expected to use the action area but could be present in Elliott Bay adjacent to the action area. There is no information on the presence of yelloweye rockfish specifically in Elliott Bay, but larvae and juveniles could be present, although they are more likely to occur in much deeper water than is present in Elliott Bay adjacent to the action area. According to Greene (2018), pelagic rockfish larvae presence in Puget Sound is seasonal, with the highest densities occurring between April and September. Though rockfish larvae are very difficult to identify to the species level, it is assumed that yelloweye rockfish larvae may be present in Elliott Bay away from the shore during the spring and summer. Snorkel and scuba surveys conducted during post-construction monitoring for the Elliott Bay Seawall Project have shown that adult rockfish are rarely observed in this part of Elliott Bay (Anchor QEA and UW 2019, 2020). One yelloweye rockfish was observed in October 2018, and the other rockfishes observed were mostly black rockfish (*Sebastes melanops*).

5.5 Puget Sound/Georgia Basin Bocaccio Distinct Population Segment

The Puget Sound/Georgia Basin DPS of bocaccio was listed as threatened on April 28, 2010 (75 FR 22276). Critical habitat was designated on November 13, 2014 (79 FR 68402). Critical habitat includes Elliott Bay but does not extend into the LDW or action area.

Bocaccio are large, long-lived rockfish that inhabit deep waters, from 160 to more than 800 feet (ranging as deep as 1,500 feet; NMFS 2009). Rockfish are viviparous (i.e., their eggs are fertilized internally) and produce 1 million to 3 million larvae annually. The larvae are released in the spring and are distributed widely in surface water, floating with tides and currents. After 3 to 6 months as larvae, juveniles move into offshore or nearshore benthic habitats including rocky reefs, kelp canopies, and structures such as piers and oil platforms. Juveniles feed on zooplankton, including the larvae of crustaceans, small fish, and invertebrates, and as they grow larger, typically move into deeper water and habitats with high roughness (i.e., rocky reefs). Adult bocaccio have a diverse diet including numerous fish species (e.g., juvenile salmon, forage fish, flatfish, pollock, lingcod) and larger invertebrates such as crabs and can be found associated with rocky or boulder benthic habitats but have also been captured in soft-bottomed habitats (NMFS 2017).

Bocaccio are difficult to sample. Historically, they appear to have been most abundant in the South Sound and Main Basin of Puget Sound (Drake et al. 2010 and Williams et al. 2010; cited in NMFS 2017).

5.5.1 Critical Habitat Presence in the Action Area

Critical habitat includes both deep water and nearshore habitats in Elliott Bay, but no critical habitat has been designated in the action area.

5.5.2 Utilization of the Action Area

Bocaccio are not expected to use the action area but could be present in Elliott Bay adjacent to the action area. Bocaccio larvae and juveniles could be present in the Elliott Bay area, although they are more likely to occur farther offshore. According to Greene (2018), pelagic rockfish larvae presence in Puget Sound is seasonal, with the highest densities occurring between April and September. Though rockfish larvae are very difficult to identify to the species level, it is assumed that bocaccio larvae may be present in Elliott Bay away from the shore during spring and summer. Snorkel and scuba surveys conducted during post-construction monitoring for the Elliott Bay Seawall Project have shown that adult rockfish are rarely observed in this part of Elliott Bay (Anchor QEA and UW 2019, 2020). No bocaccio were observed during the Elliott Bay Seawall Project post-construction surveys in 2018 and 2019.

5.6 Southern Resident Killer Whale Distinct Population Segment

The Southern Resident DPS of killer whales was listed as endangered on November 18, 2005 (79 FR 69903). Critical habitat was designated on November 29, 2006 (71 FR 69054). Critical habitat includes Elliott Bay, but no critical habitat has been designated in the action area. In September 2019, NMFS proposed a revision to the Critical Habitat Designation that is currently undergoing review (84 FR 49214). The proposed designated critical habitat would add new areas along the U.S. West Coast, but no changes are proposed in the action area.

The Southern Resident DPS contains three matrilineal groups: the J pod, K pod, and L pod. The total populations of the three pods was estimated to include approximately 73 individuals as of July 2019, its lowest number in 32 years (NOAA 2019).

The geographic distribution of Southern Resident killer whales is year-round in the coastal waters off Oregon, Washington, and Vancouver Island and off the coast of central California and the Queen Charlotte Islands (Center for Biological Diversity 2001). In the summer, Southern Resident killer whales are typically found in the Georgia Strait, Strait of Juan de Fuca, and the outer coastal waters of the continental shelf. In the fall, the J pod migrates into Puget Sound, while the rest of the population makes extended trips through the Strait of Juan de Fuca. In the winter, the K and L pods retreat from inland waters and are seldom detected in the core areas until late spring. The J pod generally remains in inland waterways throughout the winter, with most of their activity in Puget Sound. Other winter movements and range of Southern Resident killer whales are not well understood (NOAA 2019).

Killer whales use the entire water column, including regular access to the ocean surface to breathe and rest (Bateson 1974; Herman 1991). They remain underwater 95% of the time, with 60% to 70% of their time spent between the surface and a depth of 65 feet (20 meters), while diving regularly to depths of greater than 655 feet (200 meters) (Baird 1994; Baird et al. 1998). Southern Resident killer whales spend less than 5% of their time between depths of 20 and 820 feet (60 and 250 meters) (Center for Biological Diversity 2001). Time-depth recorder tagging studies of Southern Resident killer whales have documented that whales regularly dive to greater than 490 feet (150 meters), but that there is a trend toward a greater frequency of shallower dives in recent years (Baird and Hanson 2004).

The resident killer whale ecotype feeds primarily on fish, whereas transient killer whale ecotype preys on other marine mammals (NMFS 2008). Southern Resident killer whales primarily feed on salmon species (Balcomb et al. 1980; Bigg et al. 1987; NMFS 2008; Hanson et al. 2010). Chinook salmon dominate their diet (38%), followed by pink salmon (10%) and other salmon species or unidentifiable salmon species (Ford et al. 1998; Ford and Ellis 2006). Recent studies have indicated that while in their summer range, Chinook salmon from the Fraser River basin comprised 80% to 90% of the salmonid prey for Southern Resident killer whales, and fish originating in Puget Sound comprised 6%

to 14% (Hanson et al. 2010). Other species such as lingcod (*Ophiodon elongates*), halibut (*Hippoglossus stenolepis*), rockfish (*Sebastes* spp.), and Dover sole (*Microstomus pacificus*) were identified as additional prey species and may increasingly contribute to the diet as salmon populations decline (Center for Biological Diversity 2001; Hanson et al. 2010).

5.6.1 Critical Habitat Presence in the Action Area

No critical habitat has been designated in the action area.

5.6.2 Utilization of the Action Area

Southern Resident killer whales are not expected to use the action area but may be present in Elliott Bay adjacent to the action area during implementation of the proposed action.

5.7 Sunflower Sea Star

On August 18, 2021, the Center for Biological Diversity petitioned NMFS to list the sunflower sea star under the ESA. NMFS determined that the proposed action may be warranted (86 FR 73230; December 27, 2021) and began a full status review to evaluate the overall extinction risk for the species. NMFS determined that the sunflower sea star is likely to become an endangered species within the foreseeable future throughout its range and on March 16, 2023, published a proposed rule to list the sunflower sea star as a threatened species (88 FR 16212; March 16, 2023). NMFS did not propose to designate critical habitat at this time (88 FR 16212; March 16, 2023).

Information on the status of the species was provided by NMFS (Vigil 2023). The sunflower sea star is a large (up to 1 meter in diameter), fast-moving (up to 160 cm/minute), many-armed (up to 24 rays) echinoderm native to the west coast of North America. It occupies waters from the intertidal to at least 435 meters deep but is most common at depths less than 25 meters and rare in waters deeper than 120 meters. Sunflower sea stars occur over a broad array of soft-, mixed-, and hard-bottom habitats from the Aleutian Islands, Alaska, to Baja California, Mexico, but are most abundant in waters off eastern Alaska and British Columbia.

Prior to 2013, the global abundance of sunflower sea star was estimated at several billion animals; however, from 2013 to 2017, sea star wasting syndrome (SSWS) reached pandemic levels, killing an estimated 90% or more of the population. Declines in the northern portion of its range were less pronounced than in the southern portion but still exceeded 60%. Species-level impacts from SSWS, both during the pandemic and on an ongoing basis, have been identified as the major threat affecting the long-term persistence of the sunflower sea star.

The species has separate sexes and is a broadcast spawner with a planktonic larval stage. Females can release a million eggs or more. Reproduction also occurs via larval cloning, enhancing potential reproductive output beyond female fecundity. Sea stars can regenerate lost rays/arms and parts of

the central disc. Rays may detach when a sea star is injured or as a defense reaction when attacked by a predator. The longevity of the sunflower sea star in the wild is unknown, as is the age at first reproduction and the period over which a mature individual is capable of reproducing.

The sunflower sea star hunts a range of bivalves, gastropods, crustaceans, and other invertebrates using chemosensory stimuli and will dig for preferred prey in soft sediment. It preys on sea urchins and plays an important role in controlling sea urchin numbers in kelp forests. Although generally solitary, they are also known to seasonally aggregate, perhaps for spawning purposes.

5.7.1 Utilization of the Action Area

Sunflower sea star was found below RM 1.0 in the LDW during a fish tissue survey (Anchor Environmental and King County 2007). The historical and current documented range of the sunflower sea star also includes Elliott Bay, which is adjacent to the action area. Because it is a habitat generalist, there are no specific or unique habitat features that may be used to determine the likelihood or rule out the potential presence of the sunflower sea star. As such, it is possible that the sunflower sea star may also be present in the action area above RM 1.0.

5.8 Marbled Murrelet

The marbled murrelet was listed as threatened on October 1, 1992 (57 FR 45328). Critical habitat was designated on May 24, 1996 (61 FR 26256), and revised on October 5, 2011 (76 FR 61599). Critical habitat in Washington is primarily located on federal lands designated as Late Successional Reserves as part of the Northwest Forest Plan and some areas of state and county land; there is no critical habitat present in or near the action area, and critical habitat is not discussed further in this BA.

Marbled murrelets are small seabirds of the family Alcidae that occur along the north Pacific coast from Alaska to California. Murrelets forage on small fish and invertebrates in nearshore marine waters and nest inland, commonly in older coniferous forests (Lorenz et al. 2021). The nesting period in Washington State is defined as April 1 to September 23 (WSDOT 2021). The USFWS Washington Fish and Wildlife Office considers potential nest trees to be coniferous trees within 55 miles of marine waters that support at least one 4-inch-diameter platform located at least 33 feet above the ground, with horizontal and vertical cover (USFWS 2012), in a 5-acre or larger stand of mature coniferous forest. Because of the scarcity of mature forest stands, it is common for murrelets to fly inland many miles to nest, more than 70 miles in some studies (81 FR 51348). Marbled murrelets fly to and from their nest sites during dawn and dusk, spending the daytime hours foraging. The key factors of decline for the species include loss of old-growth forests with suitable nesting sites, mortality from oil spills and fishing nets, a low reproductive rate, and low nesting success and survival (USFWS 1997). In addition, it is believed that forest fragmentation makes nests vulnerable to predation by jays, crows, ravens, and great horned owls.

5.8.1 Utilization of the Action Area

The LDW is a highly industrial and urbanized waterway that lacks appropriate forage fish habitat and exhibits high levels of boat traffic and heavy industrial and commercial activity and is therefore an unfavorable location for marbled murrelet habitat or usage (City of Seattle 2015).

5.9 Western Yellow-Billed Cuckoo

Western yellow-billed cuckoos prefer to breed in large continuous riparian zones with cottonwoods (*Populus* spp.) and willows (*Salix* spp.), though nesting can also occur in fir woodlands or open brushy hillsides. The nesting season can occur from late May through late September, and nests are usually placed in willows, cottonwoods, and shrubs (WDFW 2022a). Habitat use is broader during migration and winter and consists of thick scrub, open woodlands, secondary forest, and forest edge (Hughes 2020). Only 20 sightings of yellow-billed cuckoos have been documented in Washington since the 1950s, with 80% of those sightings occurring in eastern Washington (WDFW 2022a). Rare migrants do occur, and though unlikely, it is possible that undiscovered breeding pairs may be present (WDFW 2022a). However, yellow-billed cuckoos are considered functionally extirpated in Washington.

Potential breeding or migration habitat for Western yellow-billed cuckoos is not located within or near the action area. Yellow-billed cuckoos have a highly improbable chance of occurring within the action area during construction; therefore, the project will have **no effect** on yellow-billed cuckoo, and this species is not discussed further in this BA.

5.10 North American Wolverine

The North American wolverine typically lives in boreal forest, taiga, and tundra ecosystems. In Washington, they occupy alpine and subalpine forest habitats, especially within North Cascades National Park and the wilderness areas of Okanogan-Wenatchee National Forest (WDFW 2022b). Wolverines require a snowy habitat for their young and a large range to roam.

Potential habitat for the North American wolverine is not located within or near the action area. Therefore, the project will have no effect on the North American wolverine, and this species is not discussed further in this BA.

6 Analysis of Direct and Delayed Effects

Listed species and designated critical habitat that may occur in the action area, and the associated effects determinations are summarized in Table E6-1 and the Summary of Effects Table (Attachment E.7). The potential effects that may occur during construction include underwater noise, entrainment, water quality exceedances related to turbidity and the resuspension of contaminants, changes to food resources, and modification of habitat. Most of the potential effects are short-term construction-related impacts and would not cause additional harm or a deterioration in the species' pre-action condition (*National Wildlife Federation v. NMFS* 2008). The impacts are expected to occur mainly in the LDW and to potentially affect Chinook salmon, steelhead, and bull trout. Negligible impacts, if any, are expected to affect marine species present in Elliott Bay. The proposed action is expected to improve sediment quality and benthic habitat conditions that will benefit listed species in the upper reach. Avoidance, minimization, and conservation measures and BMPs will be employed to avoid and minimize these effects, as described in Section 2.4. A detailed discussion of project-related effects is provided in the remainder of this section.

**Table E6-1
Summary of Listed Species and Designated Critical Habitat in the Action Area and Effects Determinations**

Species	Status	Agency	Effects Determination	Critical Habitat	Critical Habitat Effects Determination
Puget Sound Chinook salmon (<i>Oncorhynchus tshawytscha</i>)	Threatened (Puget Sound ESU)	NMFS	LAA	Designated	LAA
Puget Sound steelhead (<i>Oncorhynchus mykiss</i>)	Threatened (Puget Sound DPS)	NMFS	LAA	Designated	LAA
Coastal-Puget Sound bull trout (<i>Salvelinus confluentus</i>)	Threatened	USFWS	LAA	Designated	LAA
Puget Sound/Georgia Basin yelloweye rockfish (<i>Sebastes ruberrimus</i>)	Threatened (Puget Sound/ Georgia Basin DPS)	NMFS	NLAA	Designated, but none in action area	N/A
Puget Sound/Georgia Basin bocaccio (<i>Sebastes paucispinis</i>)	Threatened (Puget Sound/ Georgia Basin DPS)	NMFS	NLAA	Designated, but none in action area	N/A
Southern Resident killer whale (<i>Orcinus orca</i>)	Endangered (Southern Resident DPS)	NMFS	NLAA	Designated, but none in action area	N/A

Species	Status	Agency	Effects Determination	Critical Habitat	Critical Habitat Effects Determination
Sunflower sea star (<i>Pycnopodia helianthoides</i>)	Proposed Threatened	NMFS	NLAA	N/A	N/A
Marbled murrelet (<i>Brachyramphus marmoratus</i>)	Threatened	USFWS	NLAA	Designated, but none in action area	N/A

Notes:

Information on listed Chinook salmon, steelhead, rockfish, killer whale, and sunflower sea star species and critical habitat was obtained from the NMFS (NMFS 2022) and information on listed and proposed terrestrial bull trout and marbled murrelet species and critical habitat was obtained from the USFWS (USFWS 2022a).

DPS: distinct population segment

ESU: evolutionarily significant unit

LAA: likely to adversely affect

N/A: not applicable

NLAA: not likely to adversely affect

NMFS: National Marine Fisheries Service

USFWS: U.S. Fish and Wildlife Service

6.1 Effects to Species

Potential effects of the proposed action on listed species described in Section 5, including underwater noise effects, entrainment, water quality, resuspension of contaminants, changes to prey species, and modification of habitat are discussed in the following sections.

6.1.1 Underwater Noise Effects

Listed fish species may experience effects from underwater noise. The underwater noise generated by dredging and material placement has not been widely evaluated, but some studies have been completed. Dredging operations produce sounds that can be categorized as continuous sounds (noise produced by propellers, pumps, and generators) and repetitive sounds (produced by the dredge bucket striking the channel bottom, closing the bucket, placing material in/on a barge). The nature of the noise produced varies by the nature of material being dredged and the type and size of the dredge equipment. For example, clamshell dredging in coarse and soft sediments in Cook Inlet produced noise levels ranging from 82 to 124 dB RMS (Dickerson et al. 2001). A recent study in Elliott Bay and the Duwamish River by the Port of Seattle found that dredging is not known to increase underwater sound above background levels (Port of Seattle 2022). Due to the lack of site-specific information, it is assumed that ambient noise in the LDW is 120 dB RMS. The noise generated during dredging in Elliott Bay and the LDW was measured during five cycles and ranged from 106.5 to 137.9 dB with an average of 113.5 dB (Port of Seattle 2022). Although the upper range of the measured noise levels was higher than the ambient noise level of 120 dB RMS, it is below the 150 dB RMS threshold for impacts to fish behavior, and thresholds for physical injury to fish greater than 2 grams (187 dB sound exposure

limit [SEL]) or less than 2 grams (183 dB SEL) (Caltrans 2015). Therefore, it is expected that noise emitted from the dredging action would be below the level anticipated to affect species in the LDW.

Fish species present within the action area could, however, be subject to behavioral disturbance as a result of increased noise from vibratory pile driving (Attachment E.3). An example of a behavioral change for fish is turning away from the sound source. Juvenile and adult fish could respond by delaying foraging or migration and avoiding the project area. Although the project is intended to be constructed during the time of year when listed species are largely absent from the migratory corridor, there could still be late or early migrating juveniles or adults present. NMFS considers 150 dB RMS to be the threshold at which fish may experience behavioral effects. Vibratory pile driving may generate noise at 190 dB RMS (as described in Section 3), which exceeds this threshold. 190 dB RMS attenuates to the 150 dB RMS threshold at 1,522 feet (using the spreading loss model described in Section 3), so there is an approximately 1,522-foot radius around any pile driving activity where fish may experience behavioral effects if they are present, unless the noise attenuates at a shorter distance from coming into contact with a land mass. The width of the LDW (i.e., approximately 300 to 600 feet) is substantially less than the noise footprint generated during pile driving; therefore, pile driving would create a temporary barrier to upstream or downstream movement. Unimpeded fish movement would resume following the cessation of pile driving activity. Note that injury thresholds are higher than the noise that will be generated from the project (234 dB SEL for fish greater than 2 grams, 191 dB SEL for fish less than 2 grams, and 206 dB peak), so injury from noise is not expected to occur. Potential impacts associated with underwater noise are low based on work timing and ambient noise conditions in the action area. Underwater noise impacts will not extend into Elliott Bay waters, which are 4 miles or greater downstream, and therefore will have no effects on rockfish, the Southern Resident killer whale, or the sunflower sea star.

6.1.2 *Entrainment*

Juvenile Chinook salmon and steelhead and subadult bull trout could be entrained in dredging equipment, including land-based excavation in the wet, during dredging operations; however, this potential impact is expected to be discountable. Due to work timing restrictions, very small numbers of juvenile salmon and even fewer numbers of subadult bull trout are likely to be present in the dredge areas. Pressure waves created as the bucket descends through the water column will forewarn Chinook salmon, steelhead, and bull trout present within the area and allow individuals time to avoid the equipment. The U.S. Army Corps of Engineers (USACE) conducted extensive dredge entrainment monitoring within the Columbia River in 1985 through 1988 (Larson and Moehl 1990). In the study, no juvenile salmon were entrained due to mechanical dredging. McGraw and Armstrong (1990) examined fish entrainment rates due to mechanical dredging outside of peak migration times in Grays Harbor from 1978 to 1989 and found that one juvenile salmon was entrained. Based on this information, impacts to juvenile Chinook salmon and steelhead from entrainment during dredging

are expected to be discountable. Subadult bull trout are expected to be able to swim around the active dredge areas and would be impacted less than juvenile Chinook salmon and steelhead.

Impacts to juvenile Chinook salmon, steelhead, and bull trout from entrainment during material placement is also expected to be discountable because material placement methods (using a clamshell bucket, skip box, or telebelt) have a very low potential of entraining fish as the bucket and skip box is opening or open in the water and not closing (as with dredging). A telebelt is not operated within the water, so there is no chance of entrainment using this method.

In the unlikely event that hydraulic dredging is used for dredging, there is a risk of entrainment of juvenile Chinook salmon, steelhead, and bull trout in the cutterhead. This risk is expected to be low because the contractor performing the work would implement conservation measures to reduce the probability of entrainment, including the following: 1) not operating the dredge when the cutterhead is off the river bottom; 2) keeping the cutterhead on the bottom of the water column or a maximum of 3 feet from the bottom when necessary; and 3) turning on the suction pumps only when necessary. The risk is also expected to be low due to the timing of the construction, which is expected to occur when the lowest numbers of listed fish species are expected to be in the action area.

There is no risk of entrainment of listed Chinook salmon, steelhead, or bull trout species during the other elements of the proposed action, including piling removal or installation, reinforcing bracing piles or sheetpile wall installation, and outfall bank protection installation. Entrainment risks only apply to the immediate project area where each action is being completed and would have no effect on rockfish, the Southern Resident killer whale, or the sunflower sea star.

6.1.3 Water Quality

Dredging and placement of engineered capping material (including land-based excavation in RAA 27 that could involve removing material along the shoreline in the wet), backfill, RMC, ENR material and amended cover material could increase turbidity and suspended sediment levels and decrease the DO within the proposed action area. The removal of piles, and to a lesser extent, the installation of piles, could also increase turbidity and suspended sediment and decrease DO. The outfall bank protection installation is expected to occur in the dry and would not result in any changes to water quality. Of these activities, dredging is expected to generate the highest levels of potential impacts to water quality, including excavation that occurs in the wet when the tide is high in RAA 27. Impacts to water quality caused by the proposed action could potentially result in impacts to Chinook salmon, steelhead, and bull trout. However, water quality impacts are expected to be localized within the mixing zone radius (i.e., 150 feet) around an RAA where work is occurring because the proposed action will be required to meet water quality standards at the point of compliance. As such, these impacts are not expected to result in any long-term effects. It is anticipated that only one RAA would be dredged at a time, that dredging activities would be intermittent throughout the day and that

there could be concurrent material placement activities in a separate RAA. However, the construction sequencing will be up to the selected contractor, and it is possible that more than one RAA could be dredged simultaneously. If this happens, both areas would have to comply with water quality monitoring criteria. Water quality impacts are not expected to extend beyond the action area into Elliott Bay and would not impact rockfish, the Southern Resident killer whale, or the sunflower sea star.

Sediment and debris removed from the upper reach will be loaded onto barges, or directly into trucks during land-based excavation activities, and transported to a transload facility (facilities used to transfer sediment from a barge to an upland area for transport to the landfill) where the material will be offloaded from barges and loaded onto trucks and/or railcars for transportation to a permitted disposal facility. The locations of off-site transload facilities, if needed, would be determined by the selected contractor in their work plan. Dewatering of the dredged materials will be accomplished by gravity separation of sediment solids from the water fraction, with associated filtering before returning the water to the LDW. Due to the limited impact expected from moving sediment barges with tugs and with the implementation of BMPs to prevent accidental releases of contaminated sediments from the barges during transport, transloading, and implementation of other BMPs described in Section 2.4.4, potential effects associated with barge transport of contaminated sediment to an on-site or off-site transload facility and transloading material from the barge to the upland area are considered discountable; therefore, the barge route and transload facility are not included in the action area and effects analysis for the project.

6.1.3.1 Turbidity

Turbidity is a water quality parameter that refers to how clear the water is. Total suspended solids (TSS) are physical particles in the water (e.g., sediment), and turbidity is the effect on light caused by those particles and anything else that affects light. Therefore, there is not a constant relationship between turbidity and TSS, but they are related. The greater the amount of TSS in the water, the murkier it appears and the higher the measured turbidity.² Because turbidity is generally correlated with TSS and provides real-time feedback about water quality during dredging operations, it is commonly used as the primary tool to assess whether significant resuspension is occurring during dredging operations. For the proposed action, water quality monitoring, including turbidity, will be implemented as described in the WQMP (90% RD Volume II, Part I, Appendix A) for compliance with Washington State water quality standards. The construction contractor will be required to employ BMPs to limit water quality impacts. Should monitoring identify water quality exceedances, the contractor will be required to modify operations to correct the exceedances. See Section 2.4.1 for the impact avoidance, minimization, and conservation measure related to water quality. Based on

² Turbidity is also caused by discoloration of the water affecting light transmission through the water; therefore, the relationship between turbidity and TSS can fluctuate at any site.

literature (Thackston and Palermo 2000; Anchor Environmental 2003) and Anchor QEA's experience at other remedial dredging sites, the turbidity to TSS relationship ranges from approximately 1 nephelometric turbidity unit (NTU) = 0.5 milligram per liter (mg/L) TSS to 1 NTU = 4 mg/L TSS, with 1 NTU = 2 mg/L TSS considered to be a reasonable relationship (Attachment E.4).

In a report on the effects of resuspended sediments due to dredging operations by Anchor Environmental (2003), resuspended sediment concentrations observed worldwide near mechanical dredge operations were summarized (often within a few meters of the dredge out to approximately 300 feet from the dredge). Mean TSS concentrations above background³ were up to 404 mg/L (449 mg/L absolute) with a median of 66 mg/L. The highest TSS concentration of 449 mg/L was measured within a few meters of the dredge; these concentrations are equivalent to up to approximately 225 NTU, assuming that 1 NTU is equivalent to 2 mg/L TSS as described in the previous paragraph.

In western Washington, natural background turbidity varies seasonally when precipitation and runoff occur with higher turbidity common in fall and winter (Bash et al. 2001). Generalized turbidity effects on fish depend on the amount and timing of exposure (NMFS 2004b). In a review by Bash et al. (2001) of previous studies on the effects of turbidity and TSS concentrations on salmonids, TSS concentrations of between 488 mg/L to over 12,000 mg/L caused mortality in juvenile coho and Chinook salmon. These concentrations are equivalent to approximately 244 to 600 NTU, assuming that 1 NTU is equivalent to 2 mg/L TSS. A range of studies have illustrated the effect of turbidity levels beyond natural background on the physiology and behavior of salmonids, with chronic exposure to elevated turbidity resulting in loss or reduction of foraging capability, reduced growth, resistance to disease, increased stress, and interference with cues necessary for orientation in homing and migration (Lloyd 1987; Bash et al. 2001). Some studies have shown that in waters with periodic turbidity equivalent to 23 NTU, predation on salmonids may be reduced (Gregory 1993; Gregory and Levings 1998), an effect that may improve overall survival.

In Washington, water quality standards (WAC 173-201A-210) specify a mixing zone of 150 feet beyond which turbidity levels must not exceed 5 NTU over background (for background turbidity levels that are 50 NTU or less) or a 10% increase in turbidity when the background turbidity is more than 50 NTU. This is the criterion for excellent quality marine waters, which is the water quality category for the upper reach. It is not expected that turbidity could extend the width of the entire waterway during project activities and fully block migratory behaviors. Overall, impacts related to turbidity are expected to be localized and short-term and to be highest during dredging, land-based excavation, and material placement. Water quality standards will be required to be achieved outside of the 150-foot mixing zone, so impacts related to turbidity are expected to be limited to the 150-foot

³ Background TSS concentrations ranged from 10 mg/L to 70 mg/L, except for one dredging project which had very high (330 mg/L) background TSS (Anchor Environmental 2003).

radius from the construction activity. Impact avoidance, minimization, and conservation measures will be implemented during construction to control turbidity as described in Section 2.4, and the proposed action will be required to comply with the State of Washington's water quality standards to protect aquatic species, including listed fish species.

During dredging/excavation, material placement, and piling removal and installation activities, turbidity is not expected to elevate to a level that will lethally impact Chinook salmon, steelhead, or bull trout that may be present in the action area. Based on a review of previous dredging projects, turbidity near dredging is commonly expected to be near 33 NTU⁴ except in areas closest to dredging operations, where turbidity of up to 225 NTU could occur (Anchor Environmental 2003). However, sublethal impacts and avoidance behavior, especially in juveniles, may occur at levels associated with dredging, mainly in areas close to the dredge. Material placement activities for engineered capping, backfilling, RMC placement, ENR placement, and amended cover placement could result in increases in turbidity as the material is transported through the water column due to the presence of some fines within the clean material. However, as described in Section 2.4.5, the specifications for the imported materials will include a requirement for the materials to consist of clean, granular material free of roots, organic material, contaminants, and all other deleterious material. This requirement will minimize the amount of fines being placed and reduce the potential for elevated turbidity during placement. If elevated turbidity does occur during material placement, this condition is expected to be temporary and localized, and the activity will be monitored for water quality exceedances. The duration of elevated turbidity, if it occurs, is expected to be limited to a few hours and to be intermittent.

6.1.3.2 Total Suspended Solids

TSS, measured by determining the amount of total suspended mineral and organic particles in the water column, vary naturally in waterbodies, especially those that have higher rates of erosion (Bash et al. 2001). Elevated suspended sediment concentrations have impacts on salmonids that are similar to turbidity, including behavioral impacts (e.g., avoidance, territoriality, reduced foraging/increased predation, and delayed homing and migration) and physiological impacts (gill trauma, osmoregulation, blood chemistry, and impaired reproduction and growth) (Bash et al. 2001). When exposed to increased suspended sediment concentrations, fish are more likely to undergo sublethal stress rather than lethality because of their ability to move away from areas of higher concentration to a lower concentration versus sessile or less mobile species (Kjelland et al. 2015).

As with turbidity, dredging and material placement activities are expected to result in the highest levels of TSS. Suspended sediment concentrations vary throughout the water column, with larger plumes also typically occurring at the bottom closer to the point of dredging. Surface water samples collected

⁴ Based on converting a median TSS value of 66 mg/L by assuming that 1 NTU is equivalent to 2 mg/L TSS.

adjacent to dredge locations (within approximately 150 feet) have contained suspended sediment concentrations between 50 and 150 mg/L (Smith et al. 1979; Havis 1988; Palermo et al. 1990). Concentrations of 50 to 150 mg/L within 150 feet are expected with use of an environmental bucket and slower production rates used on sediment remediation projects. TSS concentrations from 400 to 2,000 mg/L for 4 to 96 hours have been shown to cause primary stress responses in juvenile salmonids, whereas concentrations of TSS above 4,315 mg/L for 0.5 to 57 hours in the field can result in juvenile Chinook salmon mortality (as summarized by Rich [2010]). TSS concentrations above 500 mg/L for longer than 120 hours may result in stress response or mortality for adult fishes (as summarized by Rich [2010]). Therefore, TSS concentrations expected during construction are below the concentrations that elicit a stress or mortality response in juvenile salmonids.

The mechanisms by which dredging activities will affect TSS include the impact and withdrawal of the bucket from the substrate and the loss of sediment and water out of the bucket as it moves through the water column and is loaded onto the barge (Hayes et al. 1984; Nightingale and Simenstad 2001). Increased suspended sediment could also occur during material placement as the material descends through the water column. Impact avoidance, minimization, and conservation measures (e.g., no overfilling of the dredge bucket, use of an environmental bucket when site conditions are appropriate, requirement for import material to be clean with minimal fines) will be implemented during construction to control suspended sediment, as described in Sections 2.4.2 and 2.4.5. Even without suspended sediment controls in place, plume sizes are expected to decrease rapidly with movement away from the point of dredging or material placement, both vertically and horizontally, based on a review of dredging studies (Anchor Environmental 2003). With suspended sediment controls in place, the plume sizes are expected to be even smaller. In addition, increases in suspended sediment that result from dredging activities are typically of much less magnitude than increases caused by natural storm events (Nightingale and Simenstad 2001).

Similar to turbidity, elevated TSS conditions are expected to be temporary and localized, and the activity will be monitored for water quality exceedances as described in Section 2.4.1. Based on Anchor QEA's experience with previous dredging events and based on a review of dredging projects worldwide (Anchor Environmental 2003), the duration of elevated TSS is expected to be limited to a few hours and to be intermittent.

6.1.3.3 Dissolved Oxygen

During dredging, suspension of anoxic sediment compounds may result in reduced DO in the water column as the sediments oxidize (O'Neal and Sceva 1971; Nightingale and Simenstad 2001), but any reduction in DO beyond background is expected to be limited in extent and temporary in nature. Based on a review of four studies on the effects of dredging on DO levels, LaSalle (1988) showed

little or no measurable reduction in DO around dredging operations.⁵ In addition, impacts to Chinook salmon, steelhead, and bull trout due to any potential DO depletion around dredging activities are expected to be minimal for several reasons:

- The relatively low levels of suspended material generated by dredging operations
- Counterbalancing factors in the area, such as tidal or current flushing
- DO depletion typically occurs low in the water column
- High sediment biological oxygen demand created by suspended sediment in the water column is not common (LaSalle 1988; Simenstad 1988)

Impacts to Chinook salmon, steelhead, and bull trout are also expected to be minimal during material placement activities or pile removal and installation for similar reasons.

Low DO concentrations can negatively affect the performance of migrating salmonids, reduce growth of rearing juveniles, and decrease foraging efficiency (Bjorn and Reiser 1991). However, these results occurred when salmonids were exposed to chronically low DO levels that are not expected to occur during implementation of the proposed action. Salmonid mortality occurs when DO concentrations are below 3 mg/L for periods longer than 3.5 days (Carter 2005). Long-term (20 to 30 days) constant exposure to mean DO concentrations below 3 to 3.3 mg/L is likely to result in 50% mortality of juvenile salmonids (Carter 2005). Salmonids have been reported to actively avoid areas with low DO concentrations, which is likely a protective mechanism that enhances survival (Davis 1975 as cited in Carter 2005). Field and laboratory studies have found that avoidance reactions in juvenile salmonids consistently occur at concentrations of 5 mg/L and lower, and there is some indication that avoidance is triggered at concentrations as high as 6 mg/L (Carter 2005).

None of these effects are anticipated to occur during dredging, material placement, or pile removal and installation because any reduction in DO beyond background is expected to be limited in extent and temporary in nature. There is little evidence that indicates reduced DO levels would cause injury to fish moving through the immediate area (Nightingale and Simenstad 2001), and the overall impact to DO is minimized by employing BMPs and minimization measures, as described in Sections 2.4.2, and 2.4.5. Similar, to turbidity and TSS, DO will be monitored for water quality criteria compliance during construction as described in Section 2.4.1.

6.1.4 *Resuspension of Contaminants*

The primary goal of the proposed action is to reduce the potential exposure of aquatic organisms to chemical contaminants in the sediments. Physical disruption of the contaminated sediments may occur during dredging and pile driving activities and could cause a temporary increase in dissolved

⁵ These studies included a bucket dredge operation in a channel in New York (Brown and Clark 1968); cutterhead dredge operation in Grays Harbor, Washington (Smith et al. 1976); hopper dredge operation in an Oregon tidal slough (USACE 1982); and a bucket dredging operation in a widened portion of the lower Hudson River, New York (Lunz et al. 1988).

phase concentrations of some chemicals in the vicinity of activities in subtidal, intertidal, and bank areas (if not performed in the dry). This can result from the resuspension of contaminated sediments, desorption of the contaminants from sediment particles to porewater, and release of contaminated porewater into surface water. If present in the water near the action, Chinook salmon, steelhead, and bull trout could be exposed to increased concentrations of chemical contaminants. Whether that exposure causes detrimental biological effects depends on the concentration of the chemical in the water and the duration of exposure. If contaminant concentrations are great enough or if fish exposure persists over a long enough period, the potential risk of adverse effects or bioaccumulation of some chemicals increases.

Once mobilized, metal contaminants are mostly bioavailable when in a dissolved phase, whereas organic contaminants can be bioavailable in both dissolved and particulate-bound phases. Most of the resuspended sediment settles close to the dredge within 1 hour, and only a small fraction takes longer to resettle (Wright 1978; Grimwood 1983; Van Oostrum and Vroege 1994). Therefore, most of the contaminants in the particulate fraction resuspended by dredging may not have time to desorb before they resettle to the sediment bed. The smaller-sized particles (e.g., silt and clay) could remain suspended in the water column longer and travel downstream; however, this is expected to only be a small fraction of the material since most of the resuspended sediment settles close to the dredge within 1 hour. If ingested, the particulate-bound portion of chemicals can also be toxic or contribute to bioaccumulation of chemicals in an organism's tissue. Table E6-2 provides a summary of dredging activities and associated exceedances of physical and chemical parameters observed in the water during dredging at the following LDW cleanup sites: T-117, Boeing Plant 2, and Jorgensen Forge. No chemical exceedances occurred that were attributed to the dredging activities at the points of compliance for the T-117 or Jorgensen Forge projects (AECOM 2015; Anchor QEA 2016). There were two exceedances of the chronic criterion for PCBs during the dredging activities at the Boeing Plant 2 site (Amec Foster Wheeler et. al. 2016). Based on the limited exceedances of chemical parameters observed during recent dredging activities in the LDW and the fact that most of the resuspended sediment settles close to the dredge within 1 hour, the likelihood of listed fish species ingesting particulate-bound chemicals that contribute to bioaccumulation as a result of dredging and the temporary resuspension of chemicals is low. Additionally, project timing will coincide with the in-water work window when it is less likely that juvenile Chinook salmon, steelhead, and bull trout will be present, which will reduce the potential for exposure and bioaccumulation of contaminants, further lowering the chance of fish experiencing harmful exposure.

**Table E6-2
Summary of Water Quality Monitoring Results for Recent LDW Dredge Projects**

Project	Dredging Duration	Conventional Exceedances	Chemical Exceedances
Boeing Plant 2 ¹	172 days (2013–2015, three dredge seasons)	13 turbidity exceedances	Two exceedances of the chronic criteria PCB concentrations were greater than the chronic criteria (0.03 µg/L) on January 16 and 17, 2014 (average PCB concentration of 0.067 µg/L), and August 5 and 6, 2014 (average PCB concentration of 0.031 µg/L), 300 feet downstream of dredging
T-117 ²	63 days (2013–2014, one dredge season)	None	None
Jorgensen Forge ³	45 days (2014, one dredge season)	3 turbidity exceedances	None

Notes

1. Boeing Plant 2 *Corrective Measure Implementation Report*, (Amec Foster Wheeler et al. 2016)
2. T-117 remedial action completion report (AECOM 2015)
3. Jorgensen Forge Early Action Area *Remedial Action Completion Report* (Anchor QEA 2016)

µg/L: microgram per liter

LDW: Lower Duwamish Waterway

PCB: polychlorinated biphenyl

T-117: Terminal 117

Exposure to contaminants is more likely to occur during dredging activities, including land-based excavation in the wet, than any other remedial activity because when contaminated sediments are dredged, they are disturbed and some portion of the sediment is resuspended in the water column. Placement of sand, gravel, and armor materials associated with engineered capping, backfill, RMC, ENR, and amended cover is not expected to resuspend contaminated sediments nearly as much as during dredging because the methods used to place the material minimize the potential to disturb the existing surface, as described in Section 2.4.5. Additionally, the placed material is expected to consist of sand and gravel and to settle quickly (within less than an hour) on top of the existing surface. As such, any potential impacts related to resuspension of contaminants during placement of material is expected to be discountable.

Piling removal will disturb the substrate and could result in resuspension of contaminants in the immediate vicinity of the pile, but to a lesser degree than during dredging or land-based excavation in the wet. The other elements of the proposed action, including piling installation, shoring or bracing of an existing bulkhead wall, and outfall bank protection installation, are not expected to result in a significant risk of exposure to resuspended chemical contaminants by listed Chinook salmon, steelhead, or bull trout. It is unlikely that chemicals transported downstream to Elliott Bay would be at measurable concentrations; therefore, impacts to rockfish, Southern Resident killer whales, or sunflower sea stars from exposure are not reasonably certain to occur.

The USACE DREDGE Model was used to estimate the predicted total and dissolved COPCs (arsenic, cadmium, chromium, copper, lead, mercury, silver, zinc, and PCBs) that may be mobilized into the water column during dredging at the edge of the area of mixing during construction in the upper reach of the LDW (Attachment E.4). The DREDGE Model results for the acute water quality evaluation (1-hour average; 180 cy per hour) predicted a TSS concentration of 15.6 mg/L at 150 feet from the work zone, which is the expected point of water quality compliance for field parameters and acute water chemistry criteria (Attachment E.4, Table K-4). The resulting predicted total and dissolved concentrations for COPCs did not exceed any acute water quality criteria. The DREDGE Model results for the chronic water quality criteria (4-day average; 1,000 cy per day) predicted an effective average TSS concentration of 3.6 mg/L at 150 feet from the work zone (Attachment E.4, Table K-5). The prediction of 150 feet for TSS is conservative because the chronic compliance distance is 300 feet. This is the predicted TSS concentration averaged over a 4-day period; TSS concentrations at 150 feet would be higher during active dredging. Again, all predicted total and dissolved COPC concentrations were below marine chronic water quality criteria. In summary, based on site-specific model inputs to the DREDGE Model, no acute or chronic water quality exceedances are predicted for COPCs at 150 feet from the dredging activity, assuming dredging occurs at a rate of 180 cy per hour and 1,000 cy per day or less. Dredging is not a continuous operation because the contractor will not work 24 hours per day (e.g., a typical 10-hour workday involves 6 to 8 hours of active dredging), and there is significant downtime in a typical workday for moving and setting up the dredge plant and equipment maintenance. Therefore, these production rates are considered reasonable maximum average production rates for calculating the average conditions over the time frames of interest.

Dredging production rates will vary based on the contractor's selected equipment and personnel experience, sediment physical characteristics, transport rate of dredged material to landfills, and site constraints, such as nearby vessel traffic and weather conditions (Anchor QEA and Windward 2023). In the 60% RD, it was determined that a reasonable mechanical dredging production rate in the upper reach will be approximately 1,100 cy per day in open-water areas, such as the FNC. Dredging production rates are anticipated to be lower for contingency re-dredging, nearshore dredging, and restricted access dredging, which are estimated to range from approximately 500 to 700 cy per day, with an overall site-wide weighted average production rate of 900 cy per day, which is less than the DREDGE Model rate of 1,000 cy per day. Therefore, no water quality exceedances of COPCs are anticipated during dredging at 150 feet from the dredging activity. Furthermore, water quality conditions will be monitored during construction and compared against all applicable water quality standards (WAC 173-201A-210), including required limits measured in the water column for turbidity, DO, pH, temperature, and select COC criteria (e.g., PCBs) as set forth in the WQMP (90% RD Volume II, Part I, Appendix A). The construction activities will be required to comply with water quality criteria at the points of compliance, 150 (acute) and 300 (chronic) feet downstream from the

activity. As such, fish exposure to elevated chemical concentrations in the water column is expected to mainly occur within a radius of 150 feet from the dredging activity.

Project construction for the upper reach remedial action is expected to require three construction seasons to complete. In-water construction activities will occur during the in-water work window designated for the LDW (to be determined by EPA in consultation with the Services, but anticipated to be from approximately October 1 to February 15, or an approved extension) that are set to protect migrating juvenile salmonid species and WDFW priority species. The duration of dredging within each RAA will range from a few days to several weeks. Although dredging is to occur during times of minimal juvenile Chinook salmon, steelhead, and bull trout migration, transiting individuals may be exposed to an increase in aqueous contaminant concentrations in areas within 150 feet of the dredging activity. Acute thresholds are the most appropriate screening values because dredging activities are generally intermittent throughout the day, limiting the probable exposure time frame to acute intervals. During remediation, Chinook salmon, steelhead, and bull trout are most likely to be exposed to contaminants within 150 feet of the dredge activity in surface water through surface water ventilation. Although much of the sediment and associated contaminants resuspended in the upper reach are expected to resettle close to the point of dredging, a small fraction of resuspended sediments could be distributed further away in the LDW. This is based on the fact that during dredging, most of the resuspended sediment settles close to the dredge area within 1 hour, and only a small fraction is transported downstream (Anchor Environmental 2003). Potential effects to listed fish species from exposure to metals and PCBs, which pose the greatest ecological risk, are summarized in the following paragraphs.

Metals: Based on laboratory results and field observations (Lee et al. 1975; Brannon et al. 1976; Wright 1978; Hirst and Aston 1983; EVS 1997), studies have concluded that releases of dissolved metals from the sediments during dredging were minimal, even in highly contaminated areas. Even though total metals can be released during dredging, concentrations of bioavailable dissolved metals are low and of short duration (i.e., expected to occur during active dredging within an RAA and to go away within 1 hour of stopping; dredging will be intermittent throughout the day) (USACE 2015; Anchor Environmental 2003). The lack of bioavailable dissolved metals is confirmed by the DREDGE Model, which estimated that no indicator metals (arsenic, cadmium, chromium, copper, lead, mercury, silver, zinc) would exceed their respective acute or chronic water quality criteria during dredging activities at a radius of 150 feet from the point of dredging and beyond (Attachment E.4, Tables K-4 and K-5).

PCBs: PCBs are a group of 209 synthetic congeners that were predominately manufactured and used as mixtures and thus often occur in complex mixtures in sediments. PCBs are stable compounds with low water solubilities, reflected by their partitioning coefficient (K_{ow}) values, which range from approximately 4.15 to 9.6 (Eisler and Belisle 1996). The degree of water solubility and bioavailability is

determined by the pattern and quantity of chlorination in the congener or mixture (Eisler and Belisle 1996). Due to their low water solubilities, PCBs predominantly partition with the sediment and suspended particulate phases in aquatic environments.

PCBs are generally not readily metabolized by invertebrates or teleosts (White et al. 1997) and tend to bioaccumulate in food chains. Acute exposure studies suggest that salmonids are not notably sensitive to a mortality endpoint (Lundin et al. 2019). However, concentrations of PCBs in juvenile salmonids can cause biological injury, such as impaired growth and reproduction (Berninger and Tillit 2018), and combine with other contaminants to suppress immune function and increase mortality following pathogen exposure (as summarized by Arkoosh et al. [1998] and Stehr et al. [2000]). PCBs accumulated by salmonids may further bioaccumulate in predators, such as marine mammals, because salmonids are an important prey source. Toxicological effects of PCB contamination in marine mammals include reproductive impairment (Addison 1989), immunotoxicity (Brouwer et al. 1989), skeletal abnormalities (Ross et al. 2000), endocrine disruption (Brouwer et al. 1989), and negative effects on population growth (Hall et al. 2006). The Southern Resident killer whales found in Puget Sound are among the world's most PCB-contaminated marine mammals (Ross et al. 2000). Although PCBs represent only one chemical class found in killer whales, they are viewed as the pre-eminent contaminant threat to high trophic level species in the northern hemisphere (Ross et al. 2000).

Although salmonids could be exposed to elevated concentrations of resuspended PCBs during dredging within a 150-foot radius of the point of dredging, the exposure is expected to be minimal. Thirty-two water samples were collected during LDW pre-design studies in 2017 and 2018 and analyzed for PCBs (Table E4-1; Windward 2020). PCBs were detected at concentrations below the aquatic life marine acute and chronic water quality criteria (10,000 and 30 nanograms per liter, respectively) in all 32 samples (Windward 2020). Because of the process of dilution and based on the dredging occurring over intermittent times throughout the day, any increases in water column PCB concentrations from dredging are expected to be temporary and transient. This expectation is supported by the DREDGE Model estimates that PCBs would not exceed acute or chronic water quality criteria during dredging activities at a radius of 150 feet (Washington State water quality criteria compliance distance; see Attachment E.4) from the point of dredging and beyond. Furthermore, water quality monitoring will be implemented to track that chemical concentrations above acute and chronic water quality standards are achieved within 150 feet and 300 feet, respectively, of the dredge area.

Although some fine-grained contaminated particulates may remain resuspended in the water column and travel downstream beyond the 150-foot radius from the point of dredging, the amount of these particulates is expected to be very small, and chemical concentrations are expected to be very low. In addition, following dredging, the dredged area will either be backfilled to grade with habitat suitable sand and gravel material in the shallow subtidal and intertidal zones, or an RMC layer of sand will be placed. With either backfill or RMC placement, the chemical concentration of the

sediment surface left after remediation, including placement of RMC and backfill material, will be lower than the existing surface, thereby reducing existing exposure levels to Chinook salmon, steelhead, and bull trout over the long term.

Additionally, project timing, including dredging, will coincide with the in-water work window, when it is less likely that juvenile Chinook salmon, steelhead, and bull trout will be present, reducing the potential for exposure and bioaccumulation of contaminants and lowering the chance of the fish experiencing harmful exposure. The areas to be dredged generally do not include high-quality habitat for salmonids, including Chinook salmon. As such, the fish are expected to move through these areas quickly, limiting exposure to any elevated concentrations of resuspended PCBs. Due to the expected limited exposure of listed juvenile Chinook salmon to PCBs during dredging, an increase in PCBs in the juvenile fish that will potentially survive to become prey for killer whales is not expected. The proposed action will remove PCBs from the sediment and reduce post-construction exposure to salmonids, including Chinook salmon, which will benefit juvenile Chinook salmon that eventually become adult prey for killer whales.

There is also minimal chance that fish could be exposed to contaminants because of accidental spillage of chemicals or oil from construction equipment; however, spills and accidental releases of contaminants will be minimized and mitigated by implementing impact avoidance, minimization, and conservation measures, as described in Section 2.4.1.

6.1.5 Changes to Prey Species

As previously indicated, juvenile salmon diets in the action area are tied to epibenthic prey organisms occurring in shallow water areas. In-water work for this remedial action will temporarily disturb existing epibenthic organisms and habitat in the work area. As described in Section 4, the substrate along the shore is highly modified in some areas and exhibits an abundance of armoring, resulting in less area for production of epibenthic prey on bottom substrates in these shallow water locations. Other areas have more natural or restored conditions, as described in Section 4.1. Although disturbances to benthic habitat will occur during remedial activities, it is expected that—due to existing compromised habitat for prey species because of the presence of chemical contamination and the context of the work area within an already disturbed landscape—impacts to juvenile Chinook salmon, steelhead, and bull trout via disturbance of the epibenthic prey community will be minimal and short term in the immediate area of dredging and material placement. The benthic community in disturbed areas is expected to recover within 1 to 2 years with species from nearby areas moving into the disturbed area to recolonize, though this recovery will happen in stages because work will occur over multiple years. Dredging could also cause a limited increase in exposure of benthic infauna to resuspended contaminants or residuals in areas close by the dredge areas.

The areas disturbed by material placement that are not dredged (i.e., placement of ENR, amended cover, and RMC material in the dredge perimeter) would recover faster than dredged areas because some benthic invertebrates are expected to survive material placement. RMC material will be placed in these dredge perimeter areas to address residual contamination. The length of recovery is estimated to be weeks rather than 1 to 2 years expected for dredged areas and may be shorter depending on the depth of placed material. Benthic species in these areas could experience very minor increases in contaminant concentrations in the short term. Moreover, the overall purpose of conducting the removal of sediment contamination in the action area is to reduce exposure to existing contaminants and provide long-term benefits to prey species, as well as juvenile Chinook salmon, steelhead, and bull trout, by significantly improving overall benthic habitat conditions. The lower risk to juvenile salmon from contaminant exposures means that more salmon should return as adults, providing an increased prey base for the Southern Resident killer whale, a significant beneficial effect of the action. Rockfish and sunflower sea star would not be affected by changes in prey availability within the action area. Per the ROD requirements (EPA 2014), habitat areas that are dredged will be backfilled to existing grades, and additional areas will have placement of ENR materials on top of existing bed sediments. Adult salmon typically do not feed during migration, so their food source is limited to the offshore marine area (outside of the action area) and would not be impacted through implementation of the proposed action.

Subadult bull trout that may be in the action area could be feeding. Their food source is primarily other fish; therefore, their food source could be temporarily impacted by the construction of the proposed action if fish are driven away from the immediate construction area. However, they would be able to follow the prey to other areas outside of the construction area. As such, the impacts of construction of the proposed action on food sources for bull trout are expected to be insignificant. Again, the overall purpose of conducting the remedial action is to improve sediment quality and provide long-term benefits to prey species by improving benthic habitat conditions.

6.1.6 Modification of Habitat

The LDW is a migratory corridor for juvenile and adult Chinook salmon and steelhead as well as a rearing area for juvenile Chinook salmon, steelhead, and subadult bull trout, as discussed in Section 5. Nearshore habitat in the action area used by Chinook salmon, steelhead, and bull trout will be affected in the short term due to dredging/excavation, material placement, and in-water structure modification activities that will disturb and/or cover existing surface sediments. A habitat evaluation was conducted to determine impacts to habitat from implementing the remedial activities within each RAA. The impact

of remedial activities to all habitat types, including the ROD-defined “habitat areas,”⁶ (EPA 2014) was evaluated to demonstrate compliance with Section 404 of the CWA and Section 7 of the ESA.

The habitat evaluation was completed using semi-quantitative methods and the Habitat Equivalency Analysis (HEA)-based Puget Sound Nearshore Calculator (PSNC) to determine potential impacts to habitat from implementing remedial activities. The PSNC was used to evaluate impacts associated with piling removal and installation, bulkhead reinforcement, and debris pile removals. The semi-quantitative approach was used to evaluate impacts associated with dredging and material placement activities. The habitat evaluation compares existing habitat conditions to post-remediation conditions to determine potential impacts and benefits to habitat of implementing the proposed action. The habitat evaluation methods and results are described in detail in Attachment E.6.

Existing habitat conditions were developed from data and information collected as part of the Phase I and Phase II PDI (Anchor QEA and Windward 2022), including bathymetry, substrate, bank vegetation, shoreline condition, and overwater and in-water structures. Aerial imagery was also used to confirm data collected as part of the PDI. The resulting mapped habitat polygons were assigned an elevation-based habitat category relative to MLLW (“Existing Habitat Conditions,” Figures E2-2a and E2-2b). Post-remediation habitat conditions were then assigned based on engineering design details for each RAA, plus its 40-foot RMC perimeter. Remedial technologies assigned to each RAA area shown in Table E1-1. For the semi-quantitative evaluation, spatial analysis tools were used to reassign habitat categories in each RAA (plus RMC) based on changes to elevation and substrate type that would occur because of remedial activities (“Post-Remediation Habitat Conditions,” Figures E6-1a and E6-1b). Design details extracted for the PSNC included length and diameter of pilings, length and elevation of shoreline armoring removal and replacement, area and elevation of debris removal, and area of riparian disturbance.

As described in Section 2.4, impact avoidance, minimization, and conservation measures will be implemented during construction to avoid unnecessary impacts and minimize the negative effects of the proposed action. Specifically, dredge areas in shallow subtidal and intertidal areas will be backfilled to grade using suitable habitat material consisting of sand and gravel to avoid converting habitat from shallow to deep water. Also in dredge areas, RMC material will be placed after dredging within the dredge footprint (in areas not backfilled) and dredge perimeter to address residuals above the RALs.

The semi-quantitative habitat evaluation of sediment chemical remediation activities, including dredging and capping, shows that no changes in habitat type (e.g., from intertidal to shallow subtidal) are expected in 98% of the remediation areas. Changes in habitat elevation and/or

⁶ The ROD defines “habitat areas” as all areas with elevations between -10 feet MLLW and the MHHW elevation of +11.3 feet MLLW to provide design requirements for remedial activities that occur within those elevations.

degradation status⁷ are expected to occur in a total of 0.33 acre in RAAs 22, 29, 32, and 33/34/35 (Table E6-3). A change from Degraded Upper Intertidal to Degraded Lower Intertidal in RAA 22 is related to removal of two debris piles. Because these areas are adjacent to a bulkhead wall, they are still considered degraded habitat after debris removal. However, the benefit related to the debris pile removal is quantified by the PSNC, as described in the following paragraph.

Removal of scattered riprap and debris in RAA 29 from dredging in this area will result in a habitat change from Degraded Upper Intertidal to Upper Intertidal. Removal of scattered riprap and debris in RAAs 32 and 33/34/35 from dredging will result in habitat changes from Degraded Upper Intertidal to Upper Intertidal and Degraded Lower Intertidal to Lower Intertidal. In the engineered cap area in RAA 27, the existing substrate consists of riprap and debris within the cap area. Because the surface substrate in this area would be riprap armor, there is no change in substrate type post-remediation. In the engineered cap area in RAA 14/15/16, riprap armor will also be placed in a deep subtidal area that is expected to quickly fill in with native material and cover the riprap. As such, no permanent change in substrate type is expected in this area. The semi-quantitative habitat evaluation results indicate that there will be project-related habitat benefits from incidental debris/riprap removal in addition to the expected benthic habitat, sediment quality, and water quality improvements from sediment chemical remediation.

The results of the PSNC portion of the habitat evaluation are reported in DSAYs, where a DSAY represents the value of all the ecosystem services provided by 1 acre of habitat over 1 year. A negative DSAY indicates a habitat impact; a positive DSAY indicates a habitat benefit. The habitat evaluation compared baseline habitat conditions to the post-remediation habitat conditions for activities including pile installation and removal, creosote removal, bulkhead reinforcement, debris removal, and riparian disturbance and replanting. These activities are reported as habitat impacts and benefits (debits and credits) in Table E6-4. The project is expected to result in habitat impacts of -0.45 DSAYs related to piling installation, waterward shoring reinforcement of an existing bulkhead in RAA 22, and riparian disturbance in RAA 27. The project is expected to result in habitat benefits of 1.50 DSAYs related to piling and creosote removal, debris removal in RAA 22, and planting of native vegetation in RAA 27. Overall, the proposed remediation activities are expected to result in a net 1.05 DSAYs of habitat benefit.

Consideration of both the PSNC calculations and the semi-quantitative evaluation of sediment remediation areas shows that conservation offsets are not expected for the upper reach of the LDW. There are expected to be up to 1.05 DSAYs of project-related habitat benefit and net improvement

⁷ Degradation refers to habitat with overwater structures, riprap and/or debris, or that is adjacent to a bulkhead wall. The habitat type that is immediately adjacent to the bulkhead wall is considered degraded.

of nearshore habitat functions and values to ESA-listed species and their designated critical habitat related to the project.

The habitat credits resulting from these benefits will be used, as needed, to offset impacts that may occur in the remediation of the middle reach and/or the lower reach of the LDW, as described in Section 1.2 of the habitat evaluation (Attachment E.6).

Table E6-3
Semi-Quantitative Habitat Evaluation Results

RAA	Pre-Construction Habitat Type	Post-Construction Habitat Type	Area (acres)	Description of Change
22	Degraded Upper Intertidal	Degraded Lower Intertidal	0.04	Removal of delineated debris pile adjacent to bulkhead wall. This change is considered quantitatively in the PSNC evaluation.
29	Degraded Upper Intertidal	Upper Intertidal	0.08	Removal of scattered riprap/debris during sediment remediation dredging
32/33/34/35 ¹	Degraded Lower Intertidal	Lower Intertidal	0.17	Removal of scattered riprap/debris during sediment remediation dredging
32/33/34/35 ¹	Degraded Upper Intertidal	Upper Intertidal	0.01	Removal of scattered riprap/debris during sediment remediation dredging
32/33/34/35 ¹	Degraded Upper Intertidal	Upper Intertidal	0.03	Removal of scattered riprap/debris during sediment remediation dredging
Total			0.33	

Notes:

For the purposes of the habitat evaluation degradation refers to habitat with overwater structures, riprap, and/or debris or that is adjacent to a bulkhead wall.

PSNC: Puget Sound Nearshore Calculator

RAA: remedial action area

1. Areas for RAAs 32 and 33/34/35 overlapped when the conservative 40-foot outer dredge perimeter was included around each RAA to account for both post-dredging residuals and contingency dredge area.

**Table E6-4
PSNC Habitat Evaluation Results**

Habitat Change Type	Conservation Credit/Debit	Conservation Credit/Debit Description	RAA	DSAYs
Overwater Structures	Debit	Piling Installation	24/25, 26, 27	-0.01
	Credit	Piling Removal (Including Creosote Removal)	24/25, 26, 27, 30/31, 32, 33/34/35 (24/25, 26, 27, 30/31)	0.07
Boat Ramps, Jetties, and Rubble	Debit	Waterward Reinforcement of Existing Bulkhead	22	-0.09
	Credit	Debris Pile Removal	22	0.12
Riparian Vegetation	Debit	Removal of Riparian Vegetation During Construction	27	-0.35
	Credit	Planting of Riparian Vegetation After Construction	27	1.31
Total DSAYS				1.05

Notes:

DSAY: discounted-service-acre-year

PSNC: Puget Sound Nearshore Calculator

RAA: remedial action area

6.2 Effects to Designated Critical Habitat

Effects to designated critical habitat for Puget Sound ESU of Chinook salmon, Puget Sound DPS of steelhead, and Coastal-Puget Sound bull trout is detailed in the following subsections.

6.2.1 Puget Sound Chinook Salmon Evolutionarily Significant Unit Critical Habitat

Table E6-5 summarizes the PBFs present in the action area and the potential effects of the proposed action on those PBFs. Within the action area, estuarine critical habitat is present from the furthest downstream reach up to RM 3.1 according to NMFS maps, and freshwater critical habitat begins at the 102nd Street bridge, at RM 5.0, and extends upstream (NMFS 2022, 2023; 70 FR 52698). Based on currently available NMFS maps, there appears to be a gap in the critical habitat within the action area from RM 3.1 to RM 5.0.

**Table E6-5
Potential Proposed Action Effect on Chinook Salmon PBFs**

Chinook Salmon PBFs Present	Effect from Proposed Action
<p>PBF 2: Freshwater rearing sites with water quantity and floodplain connectivity to form and maintain physical habitat conditions and support juvenile growth and mobility; water quality and forage supporting juvenile development; natural cover such as shade, submerged and overhanging large wood, log jams and beaver dams, aquatic vegetation, large rocks and boulders, side channels, and undercut banks. These features are essential to conservation because without them juveniles cannot access and use the areas needed to forage, grow, and develop behaviors (e.g., predator avoidance, competition) that help ensure their survival.</p>	<p>The portion of the action area from RM 5.0 and upstream includes the freshwater rearing PBF. Construction activities could have temporary adverse effects to water quality at freshwater rearing sites due to increased turbidity and suspended sediment and decreased DO during in-water dredging, material placement, and piling removal activities. Dredging could have temporary adverse effects to water quality due to the resuspension of contaminants. Benthic invertebrates will experience short-term adverse effects due to dredging, clean material placement, and piling installation activities. The project will result in the temporary impacts to in-water habitats. These habitats will recolonize to existing or better conditions following the project, as described in Section 6.1.6. The proposed action will result in temporary disturbance to juvenile and adult forage opportunities. No long-term adverse effects to water quality are expected from the project, and water quality is predicted to improve due to removal of contaminants from the sediment. The overall purpose of conducting the remedial action is to improve sediment and provide long-term benefits to prey species by improving benthic habitat conditions.</p>

Chinook Salmon PBFs Present	Effect from Proposed Action
<p>PBF 3: Freshwater migration corridors free of obstruction with water quantity and quality conditions and natural cover such as submerged and overhanging large wood, aquatic vegetation, large rocks and boulders, side channels, and undercut banks supporting juvenile and adult mobility and survival. These features are essential to conservation because without them juveniles cannot use the variety of habitats that allow them to avoid high flows, avoid predators, successfully compete, begin the behavioral and physiological changes needed for life in the ocean, and reach the ocean in a timely manner. Similarly, these features are essential for adults because they allow fish in a non-feeding condition to successfully swim upstream, avoid predators, and reach spawning areas on limited energy stores.</p>	<p>The portion of the action area from RM 5.0 and upstream includes the freshwater migration PBF. Construction activities could have temporary adverse effects to water quality at freshwater migration sites due to increased turbidity and suspended sediment and decreased DO during in-water dredging, material placement, and piling installation activities. Dredging could have temporary adverse effects to water quality due to the resuspension of contaminants. The project will result in the temporary impacts to in-water habitats. These habitats will recolonize to existing or better conditions following the project, as described in Section 6.1.6. Underwater noise and impairments to water quality is predicted to result in avoidance behavior or changes in direction that would delay migration. Implementation of the proposed action will result in a net reduction in the number of piles by 16, which will remove obstructions from the migration corridor. No long-term adverse effects to water quality are expected from the project, and water quality is predicted to slightly improve due to removal of contaminants from the sediment. The overall purpose of conducting the remedial action is to improve sediment and provide long-term benefits to species by reducing exposure to contaminants.</p>
<p>PBF 4: Estuarine areas free of obstruction with water quality, water quantity, and salinity conditions supporting juvenile and adult physiological transitions between fresh and saltwater; natural cover such as submerged and overhanging wood, aquatic vegetation, large rocks and boulders, and side channels; and juvenile and adult forage, including aquatic invertebrates and fishes, supporting growth and maturation</p>	<p>The portion of the action area from RM 3.1 and downstream includes the estuarine PBF. Construction activities could have temporary adverse effects to turbidity, suspended sediment, and DO at estuarine rearing sites due to construction activities during in-water work. Benthic invertebrates may experience short-term adverse effects due to dredging, clean material placement, and piling installation activities. Dredging could have temporary adverse effects to water quality due to the resuspension of contaminants. The project will result in temporary impacts to in-water habitats. These habitats are expected to be recolonized to existing or better conditions following the project, as described in Section 6.1.6. The proposed action will result in temporary disturbance to juvenile and adult forage opportunities. No long-term adverse effects to water quality will result from the project. The overall purpose of conducting the remedial action is to reduce sediment contamination and provide long-term benefits to prey species by improving benthic habitat conditions.</p>

Notes:

DO: dissolved oxygen

PBF: physical or biological feature

Other PBFs not present (see Section 5)

6.2.2 *Puget Sound Steelhead Distinct Population Segment Critical Habitat*

Table E6-6 summarizes the PBFs present in the action area and the potential effects of the proposed action on those PBFs.

Table E6-6
Potential Proposed Action Effect on Steelhead PBFs

Steelhead PBFs Present	Effect from Proposed Action
<p>PBF 2: Freshwater rearing sites with water quantity and floodplain connectivity to form and maintain physical habitat conditions and support juvenile growth and mobility; water quality and forage supporting juvenile development; natural cover such as shade, submerged and overhanging large wood, log jams and beaver dams, aquatic vegetation, large rocks and boulders, side channels, and undercut banks. These features are essential to conservation because without them juveniles cannot access and use the areas needed to forage, grow, and develop behaviors (e.g., predator avoidance, competition) that help ensure their survival.</p>	<p>The portion of the action area from RM 5.0 and upstream includes the freshwater PBF.</p> <p>Construction activities could have temporary adverse effects to water quality at freshwater rearing sites due to increased turbidity and suspended sediment and decreased DO during in-water dredging, material placement, and piling removal activities.</p> <p>Dredging could have temporary adverse effects to water quality due to the resuspension of contaminants.</p> <p>Benthic invertebrates will experience short-term adverse effects due to dredging, clean material placement, and piling installation activities.</p> <p>The project will result in temporary impacts to in-water habitats. These habitats will recolonize to existing or better conditions following the project, as described in Section 6.1.6.</p> <p>The proposed action will result in temporary disturbance to juvenile and adult forage opportunities.</p> <p>No long-term adverse effects to water quality are expected from the project, and water quality is predicted to slightly improve due to removal of contaminants from the sediment. The overall purpose of conducting the remedial action is to improve sediment and provide long-term benefits to prey species by improving benthic habitat conditions.</p>

Steelhead PBFs Present	Effect from Proposed Action
<p>PBF 3: Freshwater migration corridors free of obstruction with water quantity and quality conditions and natural cover such as submerged and overhanging large wood, aquatic vegetation, large rocks and boulders, side channels, and undercut banks supporting juvenile and adult mobility and survival. These features are essential to conservation because without them juveniles cannot use the variety of habitats that allow them to avoid high flows, avoid predators, successfully compete, begin the behavioral and physiological changes needed for life in the ocean, and reach the ocean in a timely manner. Similarly, these features are essential for adults because they allow fish in a non-feeding condition to successfully swim upstream, avoid predators, and reach spawning areas on limited energy stores.</p>	<p>The portion of the action area from RM 5.0 and upstream includes the freshwater migration PBF. Construction activities could have temporary adverse effects to water quality at freshwater migration sites due to increased turbidity and suspended sediment and decreased DO during in-water dredging, material placement, and piling installation activities. Dredging could have temporary adverse effects to water quality due to the resuspension of contaminants. The project will result in temporary impacts to in-water habitats. These habitats will recolonize to existing or better conditions following the project, as described in Section 6.1.6. Underwater noise and impairments to water quality is predicted to result in avoidance behavior or changes in direction that would delay migration. Implementation of the proposed action will result in a net reduction in the number of piles by 16, which will remove obstructions from the migration corridor. No long-term adverse effects to water quality are expected from the project, and water quality is predicted to slightly improve due to removal of contaminants from the sediment. The overall purpose of conducting the remedial action is to improve sediment and provide long-term benefits to species by reducing exposure to contaminants.</p>

Steelhead PBFs Present	Effect from Proposed Action
<p>PBF 4: Estuarine areas free of obstruction with water quality, water quantity, and salinity conditions supporting juvenile and adult physiological transitions between fresh and saltwater; natural cover such as submerged and overhanging wood, aquatic vegetation, large rocks and boulders, and side channels; and juvenile and adult forage, including aquatic invertebrates and fishes, supporting growth and maturation</p>	<p>The portion of the action area from RM 5.0 and downstream includes the estuarine PBF.</p> <p>Construction activities could have temporary adverse effects to turbidity, suspended sediment, and DO at estuarine rearing sites due to construction activities during in-water work.</p> <p>Benthic invertebrates may experience short-term adverse effects due to dredging, clean material placement, and piling installation activities.</p> <p>Dredging could have temporary adverse effects to water quality due to the resuspension of contaminants.</p> <p>The project will result in temporary impacts to in-water habitats. These habitats will recolonize to existing or better conditions following the project, as described in Section 6.1.6.</p> <p>The proposed action will result in temporary disturbance to juvenile and adult forage opportunities.</p> <p>No long-term adverse effects to water quality will result from the project, and water quality is predicted to slightly improve due to removal of contaminants from the sediment. The overall purpose of conducting the remedial action is to improve sediment conditions and provide long-term benefits to prey species by improving benthic habitat conditions.</p>

Notes:

DO: dissolved oxygen

PBF: physical or biological feature

Other PBFs not present (see Section 5)

6.2.3 Coastal-Puget Sound Bull Trout Distinct Population Segment Critical Habitat

Table E6-7 summarizes the bull trout PBFs present in the action area and the potential effects of the proposed action on those PBFs.

**Table E6-7
Potential Proposed Action Effect on Bull Trout PBFs**

Bull Trout PBFs Present	Effect from Proposed Action
<p>PBF 2: Migration habitats with minimal physical, biological, or water quality impediments between spawning, rearing, overwintering, and freshwater and marine foraging habitats, including but not limited to permanent, partial, intermittent, or seasonal barriers</p>	<p>Construction activities could temporarily create an intermittent, seasonal barrier to migration due to increased turbidity, underwater noise, and in-water work.</p>
<p>PBF 3: An abundant food base, including terrestrial organisms of riparian origin, aquatic macroinvertebrates, and forage fish</p>	<p>Aquatic invertebrates will experience short-term negative effects due to pile installation, dredging, and clean material placement. Riparian habitats will be temporarily affected then restored. Forage fish may be impacted by underwater noise, turbidity, and in-water work. Overall, there may be temporary localized decreases in food base in the project area.</p>
<p>PBF 4: Complex river, stream, lake, reservoir, and marine shoreline aquatic environments, and processes that establish and maintain these aquatic environments, with features such as large wood, side channels, pools, undercut banks and unembedded substrates, to provide a variety of depths, gradients, velocities, and structure</p>	<p>Construction activities could have temporary adverse effects to water quality at estuarine rearing sites due to increased suspended sediment during in-water work.</p> <p>The project will result in the temporary removal of riparian habitat and temporary impacts to in-water habitats. These habitats will be restored and will recolonize to existing or better conditions following the project as described in Section 6.1.6.</p> <p>Though the project area does not include much complex habitat (see Section 4.2), a variety of depths and some higher quality rearing habitats are present. These areas may be temporarily impacted during construction as described previously.</p>
<p>PBF 8: Sufficient water quality and quantity such that normal reproduction, growth, and survival are not inhibited</p>	<p>Construction activities could have temporary adverse effects to water quality due to increased suspended sediment during in-water work. No long-term adverse effects to water quality will result from the project, and the project will result in an overall improvement to water quality conditions through the removal of contaminants in the sediments. Temporary adverse effects could cause reduced fitness, injury, or mortality.</p>

Notes:

PBF: physical or biological feature

Other PBFs not present (see Section 5)

7 Effects Determinations

For listed species and designated critical habitat, the range of conclusions that could result from the effects analysis for the effects determination include the following:

- **No effect:** The appropriate conclusion when the action agency determines the proposed action will not affect listed species or critical habitat.
- **May affect but not likely to adversely affect:** The appropriate conclusion when effects on listed species are expected to be discountable, insignificant, or completely beneficial. Beneficial effects are contemporaneous positive effects without any adverse effects to the species. Insignificant effects relate to the size of the impact and should never reach the scale where take occurs. Discountable effects are those extremely unlikely to occur. Based on best judgment, a person would not be able to meaningfully measure, detect, or evaluate insignificant effects or expect discountable effects to occur.
- **May affect and likely to adversely affect:** The appropriate conclusion if any adverse effect to listed species may occur as a direct or indirect result of the proposed action or its interrelated or interdependent actions, and the effect is not discountable, insignificant, or beneficial (see definition of “may affect, is not likely to adversely affect”).

For listed species, a key factor in making an effects determination and distinguishing between a significant and insignificant effect is determining whether the effect would be significant enough to cause a take. “Take,” as defined by the ESA, includes such activities that harass, harm, pursue, hunt, shoot, wound, kill, trap, capture, or collect, or attempt to engage in any such conduct (ESA Section 3[19]). “Harm” is further defined to include significant habitat modification or degradation that results in death or injury to listed species by significantly impairing behavioral patterns such as breeding, feeding, or sheltering; “harass” is further defined as actions that create the likelihood of injury to listed species to such an extent as to significantly disrupt normal behavior patterns that include, but are not limited to, breeding, feeding, or sheltering (50 CFR 17.3).

7.1 Chinook Salmon Puget Sound ESU

7.1.1 Species Effects Determination

Based on the guidance and definitions provided within the context of the ESA in the previous section and the previously discussed project effects in Section 6, the effect determination is that the proposed action **may affect and is likely to adversely affect Puget Sound Chinook salmon**.

This proposed action **may affect** Chinook salmon because of the following:

- Chinook salmon are known to rear and migrate in the Green-Duwamish river system, and outmigrating juvenile Chinook salmon may occur in the action area in low numbers even during the work window.

- Adult Chinook salmon may be moving through the action area during the in-water work window on their way to spawning areas in the upper watershed.
- Construction activities, especially pile removal and installation, could result in underwater noise that could cause behavioral disturbance.
- Construction activities could result in changes to prey species within the immediate construction area during the project and after the project is completed until benthic ecosystems fully recover.
- Construction activities may result in temporary water quality degradation (increased turbidity and suspended sediment, and decreased DO), resuspension of contaminants, or entrainment.
- Construction activities could result in short-term impacts and long-term benefits to habitat and sediment conditions from removal of contaminants.

The proposed action is **likely to adversely affect** Chinook salmon because of the following:

- Pile installation could have adverse behavioral (delayed migration or avoidance) effects on Chinook salmon due to elevated underwater noise.
- Chinook salmon could have adverse behavioral (delayed migration or avoidance) or physiological (injury or mortality) effects due to elevated turbidity and suspended sediment caused by dredging, clean material placement, and piling removal activities.
- Potential injury or mortality to juvenile Chinook salmon could occur from entrainment during dredging activities, although this effect is unlikely to occur with mechanical dredging methods.
- Dredging, clean material placement, and piling installation activities will result in removal, smothering, or disturbance of benthic invertebrates, temporarily reducing forage opportunities for Chinook salmon until areas are fully recolonized. The areas disturbed by material placement without dredging (i.e., placement of ENR, amended cover, and RMC material in the dredge perimeter) would recover faster than dredged areas because some benthic invertebrates are expected to survive material placement. RMC material will be placed in these dredge perimeter areas to address residual contamination. Benthic species in areas for RMC material placement could experience very minor increases in contaminant concentrations in the short term.
- Short-term and localized increases in resuspended sediment cause a potential risk of increased contaminant exposure to fish directly and through their prey that may be in the area.

The potential for impacts to Chinook salmon is reduced because of the following:

- In-water construction activities will occur within approved in-water work windows when fewer numbers of juvenile Chinook salmon are expected to be present in the action area.

- Impact avoidance, minimization, and conservation measures will be employed, as described in Section 2.4, to minimize potential impacts to Chinook salmon.

7.1.2 Critical Habitat Effects Determination

The designation of critical habitat is based on the life history and habitat needs of Puget Sound Chinook salmon and includes six PBFs necessary for their conservation in freshwater, estuarine, and nearshore marine habitats. In the action area, PBFs 2, 3, and 4 are present.

Based on the analysis in Section 6.2.1, the effect determination is that this proposed action **may affect, and is likely to adversely affect** designated Chinook salmon critical habitat because of the following:

- Critical habitat is present within the action area, including PBFs 2, 3, and 4.
- Construction activities could have temporary adverse effects to water quality at freshwater rearing, migration, and estuarine PBFs due to increased turbidity and suspended sediment and decreased DO during in-water dredging, material placement, and piling removal activities.
- The project will temporarily impact in-water habitats. These habitats will be restored and will recolonize following construction.
- The proposed action will temporarily disturb juvenile and adult forage opportunities and reduce the amount of forage material.

7.2 Steelhead Puget Sound DPS

7.2.1 Species Effects Determination

Based on the guidance and definitions provided within the context of the ESA in the previous section and the previously discussed project effects in Section 6, the effect determination is that the project **may affect and is likely to adversely affect** steelhead.

This proposed action **may affect** steelhead because of the following:

- Steelhead are known to rear and migrate in the Green-Duwamish river system and rearing steelhead may be present in the action area in low numbers during the work window.
- Adult steelhead may be migrating through the action area during the in-water work window on their way to spawning areas in the upper watershed.
- Construction activities, especially pile removal and installation may result in underwater noise that could cause behavioral disturbance.
- Construction activities may result in changes to prey species within the immediate construction area during the project and after the project is completed until benthic ecosystems fully recover.

- Construction activities may result in temporary water quality degradation (increased turbidity and suspended sediment, and decreased DO), resuspension of contaminants, or entrainment.
- Construction activities may result in short-term impacts and long-term benefits to habitat and sediment conditions from removal of contaminants.

The proposed action is **likely to adversely affect** steelhead because of the following:

- Pile installation could have adverse behavioral (delayed migration or avoidance) effects on steelhead due to elevated underwater noise.
- Steelhead could have adverse behavioral (delayed migration or avoidance) or physiological (injury or mortality) effects due to elevated turbidity and suspended sediment caused by dredging, clean material placement, and piling removal activities.
- Potential injury or mortality to juvenile steelhead could occur from entrainment during dredging activities, although this effect is unlikely to occur with mechanical dredging methods.
- Dredging, clean material placement, and piling installation activities will result in removal or smothering of benthic invertebrates, reducing forage opportunities until areas are fully recolonized. The areas disturbed by material placement (i.e., placement of ENR, amended cover, and RMC material in the dredge perimeter) would recover faster than dredged areas because some benthic invertebrates are expected to survive material placement. RMC material will be placed in these dredge perimeter areas to address residual contamination. Benthic species in areas for RMC material placement could experience very minor increases in contaminant concentrations in the short term.
- Short-term and localized increases in resuspended sediment cause a potential risk of increased contaminant exposure to fish directly and through their prey that may be in the area.

The potential for impacts to steelhead is reduced because of the following:

- In-water construction activities will occur within approved in-water work windows when fewer numbers of juvenile steelhead are expected to be present in the action area.
- Impact avoidance, minimization, and conservation measures and BMPs will be employed, as described in Section 2.4, to minimize potential impacts to steelhead.

7.2.2 Critical Habitat Effects Determination

The designation of critical habitat is based on the life history and habitat needs of Puget Sound steelhead and includes six PBFs necessary for their conservation in freshwater, estuarine, and nearshore marine habitats.

Based on the preceding analysis in Section 6.2.2, the effect determination is that this proposed action **may affect, and is likely to adversely affect** designated steelhead critical habitat because of the following:

- Critical habitat is present within the action area, including PBFs 2, 3, and 4.
- Construction activities could have temporary adverse effects to water quality at freshwater rearing, migration, and estuarine PBFs due to increased turbidity and suspended sediment and decreased DO during in-water dredging, material placement, and piling removal activities.
- The project will temporarily impact in-water habitats. These habitats will be restored and will recolonize following construction.
- The proposed action will temporarily disturb juvenile and adult forage opportunities and reduce the amount of forage material.

7.3 Coastal-Puget Sound Bull Trout

7.3.1 Species Effects Determination

Based on the guidance and definitions provided within the context of the ESA and the previously discussed project effects in Section 6, the effect determination is that the project **may affect, and is likely to adversely affect** bull trout.

This proposed action **may affect** bull trout because of the following:

- Bull trout are known to rear and migrate in the Green-Duwamish river system, and rearing bull trout may be present in the action area in low numbers during the work window.
- Construction activities, especially pile removal and installation, could result in underwater noise that could cause behavioral disturbance.
- Construction activities could result in changes to prey species within the immediate construction area during the project and after the project is completed until benthic ecosystems fully recover.
- Construction activities may result in temporary water quality degradation (increased turbidity and suspended sediment, decreased DO), resuspension of contaminants, or entrainment.
- Construction activities could result in short-term impacts and long-term benefits to habitat and sediment conditions from removal of contaminants.

The proposed action is **likely to adversely affect** bull trout because of the following:

- Pile installation could have adverse behavioral (delayed migration or avoidance) effects on bull trout due to elevated underwater noise.
- Bull trout could have adverse behavioral (reduced fitness) or physiological (injury or mortality) effects from elevated turbidity caused by dredging, clean material placement, and piling removal activities.
- Potential injury or mortality to juvenile bull trout could occur from entrainment during dredging activities, although this effect is unlikely to occur with mechanical dredging methods.
- Dredging, clean material placement, and piling installation activities will result in removal or smothering of benthic ecosystems, reducing forage opportunities until areas are fully recolonized. The areas disturbed by material placement without dredging (i.e., placement of ENR, amended cover, and RMC material in the dredge perimeter) would recover faster than dredged areas because some benthic invertebrates are expected to survive material placement. RMC material will be placed in these dredge perimeter areas to address residual contamination. Benthic species in areas for RMC material placement could experience very minor increases in contaminant concentrations in the short term.
- Short-term and localized increases in resuspended sediment cause a potential risk of increased contaminant exposure to fish directly and through their prey that may be in the area.

The potential for impacts to bull trout is reduced because of the following:

- In-water construction activities will occur within approved in-water work windows when fewer numbers of juvenile bull trout are expected to be present in the action area.
- Impact avoidance, minimization, and conservation measures will be employed, as described in Section 2.4, to minimize potential impacts to bull trout.

7.3.2 Critical Habitat Effects Determination

The designation of critical habitat is based on the life history and habitat needs of bull trout and includes eight PBFs necessary for their conservation in freshwater, estuarine, and nearshore marine habitats.

Based on the preceding analysis in Section 6.2.3, the effect determination is that this proposed action **may affect, and is likely to adversely modify** designated bull trout critical habitat because of the following:

- Critical habitat is present in the action area, including PBFs 2, 3, 4 and 8.
- Construction activities could temporarily create an intermittent, seasonal barrier to migration due to increased turbidity, underwater noise, and in-water work.

- Aquatic invertebrates will experience short-term negative effects due to pile installation, dredging, and clean material placement, and there may be temporary localized decreases in food base in the project area.
- Construction activities could have temporary adverse effects to water quality at estuarine rearing sites due to increased suspended sediment during in-water work.

7.4 Puget Sound/Georgia Basin Yelloweye Rockfish Distinct Population Segment

Based on the guidance and definitions provided within the context of the ESA and the previously discussed project effects in Section 6, the effect determination is that the project **may affect, but is not likely to adversely affect** Puget Sound/Georgia Basin yelloweye rockfish.

This proposed action **may affect** yelloweye rockfish because of the following:

- Larvae and juvenile yelloweye rockfish may be present in Elliott Bay adjacent to the action area during the in-water work window, which is expected to be from October 1 to February 15.
- Construction activities may result in temporary water quality degradation (increased turbidity and suspended sediment, decreased DO) and resuspension of contaminants.

The proposed action is **not likely to adversely affect** yelloweye rockfish because of the following:

- Water quality degradation (increased turbidity and suspended sediment and decreased DO) is unlikely to extend beyond the immediate project area (within 150 feet of activity) into the marine environment at a level that is measurable. This is because the proposed action will be required to comply with water quality standards, including turbidity and DO, at a point of compliance that is expected to be a 150-foot radius from the construction activity.
- A small amount of resuspended contaminants could extend beyond the immediate project area (within 150 feet of activity) and potentially into Elliott Bay, but this amount is not expected to be measurable. The proposed action will be required to comply with water quality standards, including chemical standards at a point of compliance that is expected to be a 150-foot radius from the construction activity.
- The action would reduce the concentration of contaminants in the sediment, reducing the long-term risk of exposure.

Impact avoidance, minimization, and conservation measures will be employed, as described in Section 2.4, to minimize potential impacts to yelloweye rockfish.

7.5 Puget Sound/Georgia Basin Bocaccio Distinct Population Segment

Based on the guidance and definitions provided within the context of the ESA and the previously discussed project effects in Section 6, the effect determination is that the project **may affect, but is not likely to adversely affect** Puget Sound/Georgia Basin bocaccio.

This proposed action **may affect** bocaccio because of the following:

- Larvae and juvenile bocaccio may be present in Elliott Bay adjacent to the action area during the in-water work window, which is expected to be from October 1 to February 15.
- Construction activities may result in temporary water quality degradation (increased turbidity and suspended sediment, decreased DO) and resuspension of contaminants.

The proposed action is **not likely to adversely affect** bocaccio because of the following:

- Water quality degradation (increased turbidity and suspended sediment and decreased DO) are unlikely to extend beyond the immediate project area (within 150 feet of activity) into the marine environment at a level that is measurable. This is because the proposed action will be required to comply with water quality standards, including turbidity and DO, at a point of compliance that is expected to be a 150-foot radius from the construction activity.
- A small amount of resuspended contaminants could extend beyond the immediate project area (within 150 feet of activity) and potentially into Elliott Bay, but this amount is not expected to be measurable. The proposed action will be required to comply with water quality standards, including chemical standards, at a point of compliance that is expected to be a 150-foot radius from the construction activity.
- The action would reduce the concentration of contaminants in the sediment, reducing the long-term risk of exposure.

Impact avoidance, minimization, and conservation measures will be employed, as described in Section 2.4, to minimize potential impacts to bocaccio.

7.6 Southern Resident Killer Whale Distinct Population Segment

Based on the guidance and definitions provided within the context of the ESA and the previously discussed project effects in Section 6, the effect determination is that the project **may affect, but is not likely to adversely affect** the Southern Resident killer whale.

This proposed action **may affect** the Southern Resident killer whale because of the following:

- Southern Resident killer whales may be present in Elliott Bay adjacent to the action area during the in-water work window, which is expected to be from October 1 to February 15.
- Construction activities may result in temporary water quality degradation (increased turbidity and suspended sediment, decreased DO) and resuspension of contaminants.

- Prey species (Chinook salmon) could be impacted by the proposed action.

The proposed action is **not likely to adversely affect** Southern Resident killer whales because of the following:

- Water quality degradation (increased turbidity and suspended sediment and decreased DO) are unlikely to extend beyond the immediate project area (within 150 feet of activity) into the marine environment at a level that is measurable. This is because the proposed action will be required to comply with water quality standards, including turbidity and DO, at a point of compliance that is expected to be a 150-foot radius from the construction activity.
- A small amount of resuspended contaminants could extend beyond the immediate project area (within 150 feet of activity) and potentially into Elliott Bay, but this amount is not expected to be measurable. The proposed action will be required to comply with water quality standards, including chemical standards, at a point of compliance that is expected to be a 150-foot radius from the construction activity.
- Juvenile Chinook salmon that could be exposed to resuspended contaminants within a 150-foot radius from the dredge activity are not expected to measurably increase tissue concentrations that would impact Southern Resident killer whales that may eat the adults. Additionally, the dredging would only occur during the time of year when the fewest number of juvenile Chinook salmon are expected to be present in the action area.
- The action would reduce the concentration of contaminants in the sediment, reducing the long-term risk of exposure.

Impact avoidance, minimization, and conservation measures will be employed, as described in Section 2.4, to minimize potential impacts to Southern Resident killer whales.

7.7 Sunflower Sea Star

Based on the guidance and definitions provided within the context of the ESA and the previously discussed project effects in Section 6, the effect determination is that the project **will not adversely affect** sunflower sea stars.

The proposed action **will not adversely affect** sunflower sea stars because of the following:

- Water quality degradation (increased turbidity and suspended sediment and decreased DO) are unlikely to extend beyond the immediate project area (within 150 feet of activity) into the marine environment.
- A small amount of resuspended contaminants could extend beyond the immediate project area (within 150 feet of activity) and potentially into Elliott Bay, but this amount is not expected to be measurable. The proposed action will be required to comply with water quality

standards, including chemical standards, at a point of compliance that is expected to be a 150-foot radius from the construction activity.

- The action would reduce the concentration of contaminants available within the environment, reducing the long-term risk of exposure.

Impact avoidance, minimization, and conservation measures will be employed, as described in Section 2.4, to minimize potential impacts to sunflower sea stars.

7.8 Marbled Murrelet

Based on the analysis in Section 6, the effect determination is that the proposed action for the marbled murrelet is as follows:

The project **may affect** the marbled murrelet because of the following:

- Though unlikely, there is a discountable chance that marbled murrelets could be migrating through the project area during construction.
- There is a discountable chance that marbled murrelets would forage in the project area.

This project **is not likely to adversely affect** the marbled murrelet because of the following:

- There is no suitable marbled murrelet habitat present within 0.25-mile of project activities.
- No suitable nesting habitat will be removed as part of the proposed action.
- If present, marbled murrelets could potentially be disturbed by in-air noise or could experience reduced forage availability; however, these effects would be temporary and localized to the in-air extent of the action area.

8 Essential Fish Habitat Assessment

The objective of this EFH assessment is to determine whether the proposed action “may adversely affect” designated EFH for relevant commercially, federally managed fisheries species within the action area. This section describes and assesses the EFH in the action area; the potential impacts on these habitats; and conservation and mitigation measures proposed to avoid, minimize, or otherwise offset potential adverse effects to designated EFH resulting from the proposed action.

8.1 Essential Fish Habitat Background

This section was prepared as a resource for concurrent EFH consultation with NMFS for compliance with the Magnuson-Stevens Act.

EFH is defined as “those waters and substrates necessary to fish for spawning, breeding, feeding, or growth to maturity” (16 United States Code 1802[10]). “Waters” include aquatic areas (marine waters, intertidal habitats, and freshwater streams) and their associated physical, chemical, and biological properties that are used by fish and may include aquatic areas historically used by fish where appropriate. “Substrate” includes sediment, hard bottom, structures underlying the waters, and associated biological communities. “Necessary” means the habitat required to support a sustainable fishery and the managed species’ contribution to a healthy ecosystem. “Spawning, breeding, feeding, or growth to maturity” covers a species’ full life cycle (50 CFR 600.10). The Magnuson-Stevens Act promotes the protection of these habitats through assessment and mitigation of activities that may adversely affect these habitats.

The EFH mandate applies to all species managed under a Fishery Management Plan. In Washington, Oregon, and California, there are three Fishery Management Plans covering groundfish, coastal pelagic species, and Pacific salmon. Federal agencies must consider the impact of a proposed action on all three types of EFH. The action area for this project includes the EFH for Pacific salmon and groundfish.

8.2 Potential Effects of the Proposed Action

The definition of adverse effect is “any impact that reduces quality and/or quantity of EFH, including direct (e.g., contamination or physical disruption), delayed consequences (e.g., loss of prey or reduction in species fecundity), site-specific or habitat-wide impacts, including individual, cumulative, or synergistic consequences of actions” (50 CFR 600.810).

For the proposed action, the effects of the action have been discussed in the ESA effects analysis for Chinook salmon, steelhead, and bull trout, and their respective critical habitats (Section 6.0), and collectively these apply to EFH.

The potential effects of the action include limited, short-term potential increases in turbidity and suspended sediment and decreases in DO during construction, resuspension of contaminants, removal of riparian habitat, short-term changes to food resources, and short-term and long-term changes to habitat. The overall purpose of conducting the remedial action is to improve sediment and benthic habitat conditions. Conservation measures and BMPs proposed to avoid, minimize, or otherwise offset potential adverse effects to designated EFH are described in Section 2.4.

8.2.1 *Pacific Salmon EFH Effects Determination*

The action area for this project includes the EFH for Pacific salmon, including Chinook salmon, pink salmon, and coho salmon. EFH for Pacific salmon includes all those streams, lakes, ponds, wetlands, other currently viable waterbodies, and most of the habitat historically accessible to salmon in Washington (PFMC 2022a).

Water quality avoidance and minimization measures such as working within the expected in-water work window of October 1 to February 15 or approved extension, placing material from the bottom of the slope and working up the slope to reduce the potential for sloughing, and visual turbidity monitoring and construction BMPs would help reduce the likelihood that significant levels of turbidity or suspended sediment would be generated during construction. The proposed action will temporarily impact the riparian area in RAA 27, intertidal, and subtidal habitat; however, the riparian disturbed area in RAA 27 will be restored following completion of construction and the impacts to intertidal and subtidal habitat will be temporary and localized with a long-term beneficial reduction in contaminant concentrations.

For the reasons listed previously, the proposed action **may adversely affect** Pacific salmon EFH. The short-term and temporary effects associated with the proposed action would be avoided and minimized during construction to the extent practicable. However, long-term beneficial effects on EFH are also expected as a result of the proposed action due to the reduction of chemical concentrations in the sediment.

8.2.2 *Groundfish EFH Effects Determination*

The action area for this project includes the EFH for groundfish. EFH for groundfish in the Puget Sound area include depths less than or equal to 3,500 meters to MHHW or the upriver extent of saltwater intrusion in the LDW (PFMC 2022b). The short-term and temporary effects associated with the proposed action would be avoided and minimized during construction to the extent practicable as described previously but will result in temporary disturbance to the benthic habitat that will take weeks to 1 to 2 years to recover and may result in a temporary increase in contaminant exposure. For the reasons listed previously, the proposed action **may adversely affect** groundfish EFH. However, the proposed action will also have a long-term beneficial effect to the benthic habitat due to the reduction in contaminant concentrations in the substrate.

9 References

- Addison, R.F., 1989. "Organochlorines and Marine Mammal Reproduction." *Canadian Journal of Fisheries and Aquatic Science* 46:360–368.
- AECOM, 2012. *Final Feasibility Study for the Lower Duwamish Waterway, Seattle, WA*. Prepared for the Lower Duwamish Waterway Group for submittal to U.S. Environmental Protection Agency, Region 10 and Washington State Department of Ecology, Northwest Regional Office. October 31, 2012.
- AECOM, 2015. *Terminal 117—Water Quality Monitoring Program Implementation Memorandum*. From Anne Fitzpatrick, Noah Garguilo (AECOM) and Tad Deshler (Coho Environmental) to Roy Kuriowa (Port of Seattle), June 22, 2015.
- Amec Foster Wheeler Environment & Infrastructure, Inc., Dalton, Olmsted & Fuglevand, Inc., and Floyd|Snider, Inc., 2016. *Corrective Measure Implementation Report*. Duwamish Sediment Other Area and Southwest Bank Corrective Measure, Boeing Plant 2, Seattle/Tukwila, WA. June 2016.
- Anchor Environmental (Anchor Environmental, L.L.C.), 2003. *Literature Review of Effects of Resuspended Sediments Due to Dredging Operations*. Prepared for the Los Angeles Contaminated Sediments Task Force. June 2003.
- Anchor Environmental and King County (Anchor Environmental, L.L.C.; King County Department of Natural Resources and Parks), 2007. *Data Report: Fish Tissue Sampling and Chemical analysis in the Lower Duwamish Waterway*. Seattle, Washington.
- Anchor QEA, 2016. *Removal Action Completion Report, Jorgensen Forge Early Action Area*. Prepared for U.S. Environmental Protection Agency. May 2016.
- Anchor QEA and UW (Anchor QEA, LLC; University of Washington), 2019. *Elliott Bay Seawall Project: 2018 Post-Construction Monitoring Report (Year 1)*. Prepared for the Seattle Department of Transportation. January 2019.
- Anchor QEA and UW, 2020. *Draft Elliott Bay Seawall Project: 2019 Post-Construction Monitoring Report (Year 2)*. Prepared for the Seattle Department of Transportation. January 2020.
- Anchor QEA and Windward (Anchor QEA, LLC; Windward Environmental LLC), 2022. *Pre-Design Investigation Data Evaluation Report for the Lower Duwamish Waterway Upper Reach*. Prepared for U.S. Environmental Protection Agency. July 15, 2022.

- Anchor QEA and Windward, 2023. *Intermediate (60%) Remedial Design Basis of Design Report for Lower Duwamish Waterway Upper Reach*. Submitted to U.S. Environmental Protection Agency February 20, 2023.
- Arkoosh, M.R., E. Casillas, E. Clemons, A.N. Kagley, R. Olsen, P. Reno, and J.E. Stein, 1998. "Effects of Pollution on Fish Diseases: Potential Impacts on Salmonid Populations." *Journal of Aquatic Animal Health* 10:182–190.
- Averett, D.E., D.F. Hayes, and P.R. Schroeder, 1999. "Estimating Contaminant Losses During Dredging," *Proceedings of World Dredging Association, 19th Technical Conference*.
- Baird, R.W., 1994. *Foraging Behavior and Ecology of Transient Killer Whales*. PhD thesis. Burnaby, British Columbia, Canada. Simon Fraser University.
- Baird, R.W., and M.B. Hanson, 2004. *A Progress Report on Diving Behavior of Southern Resident Killer Whales*. Contract report under Order No. AB133F-03-SE-1070.
- Baird, R.W., L.M. Dill, and M.B. Hanson, 1998. "Diving Behavior of Killer Whales." Abstract of a paper presented at the World Marine Mammal Conference (Monaco); January 1998.
- Balcomb, K.C., J.R. Boran, R.W. Osborne, and N.J. Haenel, 1980. *Observations of Killer Whales (Orcinus orca) in Greater Puget Sound, State of Washington*. NTISPB80-224728, U.S. Department of Commerce.
- Bash, J., C. Berman, and S. Bolton, 2001. *Effects of Turbidity and Suspended Solids on Salmonids*. Final research report. Prepared for Washington State Department of Transportation, Research Project T1803, Task 42. November 2001.
- Bateson, G., 1974. "Observations of a Cetacean Community." *Mind in the Waters*. Editor, J. McIntyre. New York: Charles Scribner's Sons, Sierra Club Books; pp. 146–165.
- Battelle (Battelle Marine Sciences Laboratory); Pentec Environmental; Striplin Environmental Associates; Shapiro Associates, Inc.; and King County Department of Natural Resources, 2001. *Reconnaissance Assessment of the State of the Nearshore Ecosystem: Eastern Shore of Central Puget Sound, Including Vashon and Maury Islands (WRIAs 8 and 9)*.
- Berninger, J.P., and D.E. Tillitt, 2018. "Polychlorinated Biphenyl Tissue-Concentration Thresholds for Survival, Growth, and Reproduction in Fish." *Environmental Toxicology and Chemistry* 38(4):712–736.

- Bigg, M.A., G.M. Ellis, J.K.B. Ford, and K.C. Balcomb, 1987. *Killer Whales: A Study of Their Identification, Genealogy, and Natural History in British Columbia and Washington State*. Nanaimo, British Columbia: Phantom Press.
- Bisson, P.A., R.E. Bilby, M.D. Bryant, et al., 1987. "Large Woody Debris in Forested Streams in the Pacific Northwest: Past, Present, and Future." *Streamside Management – Forestry and Fisheries Interactions: Proceedings of a Symposium, University of Washington, February 12–14, 1986*. Editors, T. Cundy and E. Salo. Seattle: pp. 143–190.
- Bjorn, T.C., and D.W. Reiser, 1991. "Habitat Requirements of Salmonids in Streams." *Influences of Forest and Rangeland Management on Salmonid Fishes and their Habitats*. Special publication, volume 19. Editor, W.R. Meehan. Bethesda, Maryland: American Fisheries Society.
- Blomberg, G., C. Simenstad, and P. Hickey, 1988. "Changes in Duwamish River Estuary Habitat Over the past 125 Years." *Proceedings of the First Annual Meeting on Puget Sound Research*. Seattle, Washington.
- Brannon, J.M., R.M. Engler, J.R. Rose, P.G. Hunt, and I. Smith, 1976. *Selective Analytical Partitioning of Sediments to Evaluate Potential Mobility of Chemical Constituents During Dredging and Disposal Operations*. Technical Report D-76-7. Prepared for Office, Chief of Engineers, U.S. Army. December 1976.
- Brouwer, A., P.J.H. Reijnders, and J.H. Koeman, 1989. "Polychlorinated Biphenyl (PCB)-Contaminated Fish Induces Vitamin A and Thyroid Hormone Deficiency in the Common Seal (*Phoca vitulina*)." *Aquatic Toxicology* 15:99–106.
- Brown, C.L. and R. Clark, 1968. "Observations on Dredging and Dissolved Oxygen in a Tidal Waterway." *Water Resources Research* 4:1381–1384.
- Busby, P.J., T.C. Wainwright, G.J. Bryant, L.J. Lierheimer, R.S. Waple, F.W. Waknitz, and I.V. Lagomarsino, 1996. *Status Review of West Coast Steelhead from Washington, Idaho, Oregon, and California*. NOAA Technical Memorandum NMFS-NWFSC-27. August 1996.
- Caltrans (California Department of Transportation), 2015. *Technical Guidance for Assessment and Mitigation of the Hydroacoustic Effects of Pile Driving on Fish*. November 2015. Available at: <https://dot.ca.gov/-/media/dot-media/programs/environmental-analysis/documents/env/bio-tech-guidance-hydroacoustic-effects-110215-a11y.pdf>.
- Carr, S.A., M.H. Laurinolli, C.D.S. Tollefsen, and S.P. Turner, 2006. *Cacouna Energy LNG Terminal: Assessment of Underwater Noise Impacts*. Technical report prepared by JASCO Research, Ltd., for Golder Associates Ltd., p. 65.

- Carter, K., 2005. *The Effects of Dissolved Oxygen on Steelhead Trout, Coho Salmon, and Chinook Salmon Biology and Function by Life Stage*. California Regional Water Quality Control Board, North Coast Region. August 2005.
- Center for Biological Diversity, 2001. *Petition to List the Southern Resident Killer Whale (Orcinus orca) as an Endangered Species Under the Endangered Species Act*. May 1, 2001.
- City of Seattle, 2015. "Section 5: Status of the Species." *Seattle Biological Evaluation Document*. Updated June 11, 2015. Available at: <https://www.seattle.gov/utilities/construction-resources/standards-and-guidelines/seattle-biological-evaluation>.
- Dickerson, C., K.J. Reine, and D.G. Clarke, 2001. "Characterization of Underwater Sounds Produced by Bucket Dredging Operations." DOER Technical Notes Collection (ERDC TN-DOER-E14). U.S. Army Engineer Research and Development Center. Available at: <https://www.fisheries.noaa.gov/resource/document/characterization-underwater-sounds-produced-bucket-dredging-operations>.
- Ecology (Washington State Department of Ecology), 2022a. "Water Quality Assessment and 303(d) List." Accessed December 28, 2022. Available at: <https://ecology.wa.gov/Water-Shorelines/Water-quality/Water-improvement/Assessment-of-state-waters-303d>.
- Ecology, 2022b. "Water Quality Atlas Map." Accessed November 15, 2022. Available at: <https://apps.ecology.wa.gov/waterqualityatlas/wqa/map>.
- Eggleton, J. and K.V. Thomas, 2004. "A Review of Factors Affecting the Release and Bioavailability of Contaminants During Sediment Disturbance Events." *Environmental International* (30):973-980.
- Eisler, R., and A.A. Belisle, 1996. "Planar PCB Hazards to Fish, Wildlife, and Invertebrates: A Synoptic Review." *Contaminant Hazard Reviews* 31.
- EPA (U.S. Environmental Protection Agency), 2014. *Record of Decision*. Lower Duwamish Waterway Superfund Site. November 2014.
- EPA, 2018. Fourth Amendment of the Administrative Order on Consent for Remedial Investigation/Feasibility Study (AOC4). U.S. Environmental Protection Agency, Region 10, CERCLA Docket No. 10-2001-0055 and Ecology Docket No 00TCPNR-1895. July 9, 2018.
- EPA, 2021. *Explanation of Significant Differences*. Lower Duwamish Waterway Superfund Site. September 2021.

- Everest, F.H., and D.W. Chapman, 1972. "Habitat Selection and Spatial Interaction by Juvenile Chinook Salmon and Steelhead Trout in Two Idaho Streams." *Journal of the Fisheries Research Board of Canada* 29:91–100.
- EVS, 1997. "Release of Contaminants from Resuspended Particulate Matter." White Paper, EVS.
- Ford, J.K.B., and G.M. Ellis, 2006. "Selective Foraging by Fish-Eating Killer Whales *Orcinus orca* in British Columbia." *Marine Ecology Progress Series* 316:185–199.
- Ford, J.K.B., G.M. Ellis, L.G. Barrett-Lennard, A.B. Morton, R.S. Palm, and K.C. Balcomb, 1998. "Dietary Specialization in Two Sympatric Populations of Killer Whales (*Orcinus orca*) in Coastal British Columbia and Adjacent Waters." *Canadian Journal of Zoology* 77:2000.
- Ford, M. J., editor, 2022. *Biological Viability Assessment Update for Pacific Salmon and Steelhead Listed Under the Endangered Species Act: Pacific Northwest*. U.S. Department of Commerce, NOAA Technical Memorandum NMFS-NWFSC-171.
- Fresh, K.L., 2006. *Juvenile Pacific Salmon in Puget Sound*. Prepared in Support of the Puget Sound Nearshore Partnership. NOAA Fisheries Service, Northwest Fisheries Science Center. Technical Report 2006-06.
- Frissell, C.A., P.H. Morrison, S.B. Adams, L.H. Swope, and N.P. Hitt, 2000. "Conservation Priorities: An Assessment of Freshwater Habitat for Puget Sound Salmon." *The Trust for Public Lands*; p. 138.
- Greene, A., 2018. *Nearshore Larval Fishes of Puget Sound*. Master's thesis: University of Washington; School of Aquatic and Fishery Sciences.
- Gregory, R.S., 1993. "Effect of Turbidity on the Predator Avoidance Behaviour of Juvenile Chinook Salmon (*Oncorhynchus tshawytscha*)." *Canadian Journal of Fisheries and Aquatic Sciences* 50:241–246.
- Gregory, R.S., and C.D. Levings, 1998. "Turbidity Reduces Predation on Migrating Juvenile Pacific Salmon." *Transactions of the American Fisheries Society* 127: 275–285.
- Grimwood, C., 1983. "Effects of Dredging on Adjacent Water." *ASCE Journal of Environmental Engineering* 109(1):47–65.
- Hall, A.J., B.J. Connell, R.K. Rowles, A. Aguilar, A. Borrell, L. Schwacke, P.J.H. Reijnders, and R.S. Wells, 2006. "Individual-Based Model Framework to Assess Population Consequences of Polychlorinated Biphenyl Exposure In Bottlenose Dolphins." *Environmental Health Perspective* 114:60–64.

- Hanson, M.B., R.W. Baird, J.K.B. Ford, J. Hempelmann-Halos, D.M. Van Doornik, J.R. Candy, C.K. Emmons, G.S. Schorr, B. Gisborne, K.L. Ayres, S.K. Wasser, K.C. Balcomb, K. Balcomb-Bartok, J.G. Sneva, and M.J. Ford, 2010. "Species and Stock Identification of Prey Consumed by Endangered Southern Resident Killer Whales in their Summer Range." *Endangered Species Research* 11:69–82.
- Hard, J.J., J.M. Myers, M.J. Ford, R.G. Kope, G.R. Pess, R.S. Waples, G.A. Winans, B.A. Berejikian, F.W. Waknitz, P.B. Adams, P.A. Bisson, D.E. Campton, and R.R. Reisenbichler, 2007. *Status Review of Puget Sound Steelhead (Onchorhynchus mykiss)*. NOAA Technical Memorandum NMFS-NWFSC-81. June.
- Harper-Owes (Harper-Owes Company), 1983. *Water Quality Assessment of the Duwamish Estuary, Washington*. Prepared for Municipality of Metropolitan Seattle.
- Havis, R. N., 1988. "Sediment Resuspension by Selected Dredges." Environmental Effects of Dredging Technical Note EEDP-09-2. U.S. Army Engineer Waterways Experiment Station.
- Hayes, D.F., G.L. Raymond, and T.N. McLellan, 1984. "Sediment Resuspension from Dredging Activities." *Dredging and Dredged Material Disposal: Dredging '84 Conference Proceedings*. Clearwater Beach, Florida: American Society of Civil Engineers; pp. 72–82.
- Herman, L.M., 1991. "What the Dolphin Knows, or Might Know, in Its Natural World." *Dolphin Societies: Discoveries and Puzzles*. Editors, K.W. Pryor and L.S. Norris. Berkley, California: University of California Press; pp. 349–363.
- Hillman, T.W., J.S. Griffith, and W.S. Platts, 1987. "Summer and Winter Habitat Selection by Juvenile Chinook Salmon in a Highly Sedimented Idaho Stream." *Transactions of the American Fisheries Society* 116:185–195.
- Hirst, J.M. and S.R. Aston, 1983. "Behaviour of Copper, Zinc, Iron and Manganese During Experimental Resuspension and Reoxidation of Polluted Anoxic Sediments." *Estuarine, Coastal, and Shelf Science* 16:549–558.
- Hughes, J., 2020. "Yellow-Billed Cuckoo (*Coccyzus americanus*)." Birds of the World. Cornell Lab of Ornithology. Available at: <https://doi.org/10.2173/bow.yebcuc.01>.
- Kerwin, J., and T. S. Nelson, editors, 2000. *Habitat Limiting Factors and Reconnaissance Assessment Report, Green/Duwamish and Central Puget Sound Watersheds (WRIA 9 and Vashon Island)*. Washington Conservation Commission and King County Department of Natural Resources.

- Johnson, S.W., J.F. Thedinga, and K.V. Koski, 1992. "Life History of Juvenile Ocean-Type Chinook Salmon (*Oncorhynchus tshawytscha*) in the Situk River, Alaska." *Canadian Journal of Fisheries and Aquatic Sciences* 49:2621–2629.
- King County, 2001. "Chapter 11: Elliott Bay and the Duwamish River Estuary." *Reconnaissance Assessment of the State of the Nearshore Report Including Vashon and Maury Islands (WRIAs 8 and 9)*. Available at: <https://kingcounty.gov/services/environment/watersheds/central-puget-sound/nearshore-environments/reconnaissance-assessment.aspx>.
- King County, 2021. *Green/Duwamish and Central Puget Sound Watershed Salmon Habitat Plan 2021 Update*. Updated February 11, 2021. Available at: https://www.govlink.org/watersheds/9/pdf/2021_PlanUpdate.pdf.
- Kjelland, M.E., C.M. Woodley, T.M. Swannack, and D.L. Smith, 2015. "A Review of Potential Effects of Suspended Sediment on Fishes: Potential Dredging-Related Physiological Behavior, and Transgenerational Implications." *Environmental Systems and Decisions* 33:334–350.
- Knutson, K. L., and V. L. Naef. 1997. *Management Recommendations for Washington's Priority Habitats: Riparian*. Washington Department of Fish and Wildlife; p. 181.
- Lambert, M.R., R. Ojala-Barbour, R. Vadas Jr., A.P. McIntyre, and T. Quinn, 2021. *Small Overwater Structures: A Review of Effects on Puget Sound Habitat and Salmon*. Prepared for Washington Department of Fish and Wildlife. September 2021. Available at: <https://wdfw.wa.gov/sites/default/files/publications/02289/wdfw02289.pdf>.
- Larson, K.W., and C.E. Moehl, 1990. "Entrainment of Anadromous Fish by Hopper Dredge at the Mouth of the Columbia River." *Effects Of Dredging on Anadromous Pacific Coast Fishes*. Editor, C.A. Simenstad. Seattle: Washington Sea Grant; pp. 104–110.
- LaSalle, M.W., 1988. "Physical and Chemical Alterations Associated with Dredging: An Overview." Presentation in the *1988 Effects of Dredging on Anadromous Pacific Coast Fishes* workshop, Sponsored by Wetland Ecosystem Team, Fisheries Research Institute: University of Washington, Seattle, Washington.
- Lee, G.F., M.D. Piwoni, J.M. Lopez, G.M. Mariani, J.S. Richardson, D.H. Homer, and F. Saleh, 1975. *Research Study for the Development of Dredged Material Disposal Criteria*. Contract Report D-75-4. U.S. Army Corps of Engineers, Waterways Experiment Station.
- Lloyd, D.S., 1987. "Turbidity as a Water Quality Standard for Salmonid Habitats in Alaska." *North American Journal of Fisheries Management* 7:34–45.

- Lorenz, T.J., M.G. Raphael, R.D. Young, D. Lynch, S.K. Nelson, and W.R. Mclver, 2021. *Status and Trend of Nesting Habitat for the Marbled Murrelet Under the Northwest Forest Plan, 1993 to 2017*. Prepared by the U.S. Department of Agriculture, Forest Service, Pacific Northwest Research Station, General Technical Report PNW-GTR-009. September 2021.
- Lundin, J.I., J.A. Spromberg, J.C. Jorgensen, J.M. Myers, P.M. Chittaro, R.W. Zabel, L.L. Johnson, R.M. Neely, and N.L. Scholz, 2019. "Legacy Habitat Contamination as a Limiting Factor for Chinook Salmon Recovery in the Willamette Basin, Oregon, USA." *PLoS ONE* 14(3):e0214399.
- Lunz, J.D., M.W. LaSalle, and L. Houston, 1988. "Predicting Dredging Impacts on Dissolved Oxygen." *Proceedings of the First Annual Meeting of the Puget Sound Research, Puget Sound Water Quality Authority*. Seattle, Washington; pp. 331–336.
- McGraw, K.A., and D.A. Armstrong, 1990. "Fish Entrainment by Dredges in Grays Harbor, Washington." *Effects Of Dredging On Anadromous Pacific Coast Fishes*. Editor, C.A. Simenstad. Seattle: Washington Sea Grant; pp. 113–131.
- Myers, J.M., J.J. Hard, E.J. Connor, R.A. Hayman, R.G. Kope, G. Lucchetti, A.R. Marshall, G.R. Pess, and B.E. Thompson, 2015. *Identifying Historical Populations of Steelhead within the Puget Sound Distinct Population Segment*. U.S. Department of Commerce, NOAA Technical Memorandum. NMFS-NWFSC-128. Available at: <https://wdfw.wa.gov/publications/01508>.
- National Wildlife Federation v. National Marine Fisheries Service*. 425 F.3d 917 (9th Circuit 2008).
- Nightingale, B., and C. Simenstad, 2001. *Dredging Activities: Marine Issues*. White paper. Submitted to Washington Department of Fish and Wildlife, Washington Department of Ecology, and Washington Department of Transportation. University of Washington, School of Aquatic and Fishery Sciences, Wetland Ecosystem Team.
- NMFS (National Marine Fisheries Service), 2003. *Endangered Species Act – Section 7 Consultation Biological Opinion and Magnuson–Stevens Fishery Conservation and Management Act Essential Fish Habitat Consultation for Middle Waterway Remediation Action, Commencement Bay Nearshore/Tideflats Superfund Site, Tacoma, Washington*. NMFS Tracking No.: 2003/00574. September 2003.
- NMFS, 2004a. *Biological Opinion: Edmonds Crossing Ferry Terminal*. NOAA Tracking Number 2003/00756. Prepared for the Federal Highway Administration. May 25, 2004.

- NMFS, 2004b. *Endangered Species Act – Section 7 Consultation Biological Opinion and Conference Opinion and Magnuson-Stevens Fishery Conservation and Management Act Essential Fish Habitat Consultation City of Portland Maintenance Dredging at Fire Station No. 6 Harbor, Willamette River, Willamette River/Columbia River HUC, Multnomah County, Oregon (Corps No. 200200811)*. NOAA's National Marine Fisheries Service Northwest Region. October 14.
- NMFS, 2005. *Salmon at River's End: The Role of the Estuary in the Decline and Recovery of Columbia River Salmon*. NOAA Technical Memorandum NMFS-NWFSC-68. August 2005.
- NMFS, 2008. *Recovery Plan for Southern Resident Killer Whales (Orcinus orca)*. National Marine Fisheries Service, Northwest Region. January 2008.
- NMFS, 2009. *Endangered and Threatened Wildlife and Plants: Proposed Endangered, Threatened, and Not Warranted Status for Distinct Population Segments of Rockfish in Puget Sound*. 50 Code of Federal Regulations Parts 223 and 224. April 23. Available at:
<http://www.nmfs.noaa.gov/pr/pdfs/fr/fr74-18516.pdf>
- NMFS, 2017. *Rockfish Recovery Plan: Puget Sound/Georgia Basin Yelloweye Rockfish (Sebastes ruberrimus) and Bocaccio (Sebastes paucispinis)*. Prepared by Office of Protected Resources, West Coast Regional Office, National Marine Fisheries Service.
- NMFS, 2022. "ESA Threatened and Endangered Species Directory." Accessed October 14, 2022. Available at: <https://www.fisheries.noaa.gov/species-directory/threatened-endangered>.
- NMFS, 2023. "Protected Resources Mapper." Accessed February 15, 2023. Available at:
<https://www.webapps.nwfsc.noaa.gov/portal/apps/webappviewer/index.html?id=7514c715b8594944a6e468dd25aaacc9>.
- NOAA (National Oceanic and Atmospheric Administration), 2002. *Hylebos Waterway Natural Resource Damage Settlement Proposal Report: A Habitat Restoration-Based Approach for Resolving Natural Resource Damage Claims Relating to the Hylebos Waterway of the Commencement Bay Nearshore/Tideflats Superfund Site, Combined with a Proposal for Allocating Liability for Settlement Purposes*. Public Review Draft, March 14, 2002.
- NOAA, 2013. *Final Lower Duwamish River NRDA Restoration Plan and Programmatic Environmental Impact Statement*. Prepared by the National Oceanic and Atmospheric Administration on behalf of the Lower Duwamish River Natural Resource Damage Assessment Trustee Council. June 2013.
- NOAA, 2019. "Protected Species: Southern Resident Killer Whale." Accessed March 28, 2023. Available at: <https://www.fisheries.noaa.gov/species/killer-whale>.

- NOAA, 2022a. "Puget Sound Chinook Salmon." Accessed October 27, 2022. Available at: <https://www.fisheries.noaa.gov/west-coast/endangered-species-conservation/puget-sound-chinook-salmon#:~:text=Species%20Status,-ESA%20Listing%20Status&text=ESU%20Description%3A%20This%20evolutionarily%20significant,and%20the%20Strait%20of%20Georgia>.
- NOAA, 2022b. "Puget Sound Steelhead." Accessed October 27, 2022. Available at: <https://www.fisheries.noaa.gov/west-coast/endangered-species-conservation/puget-sound-steelhead#:~:text=The%20Puget%20Sound%20steelhead%20is,under%20the%20Endangered%20Species%20Act>.
- ODFW (Oregon Department of Fish and Wildlife), 2005. *Biology, Behavior, and Resources of Resident and Anadromous Fish in the Lower Willamette River, Final Report of Research, 2000–2004*. Editor, T. Friesen. Prepared for City of Portland Bureau of Environmental Services, Endangered Species Act Program.
- O'Neal, G., and J. Sceva, 1971. *The Effects of Dredging on Water Quality in the Northwest*. Prepared for the Environmental Protection Agency, Office of Water Programs, Region X. July 1971.
- Ostergaard, E., D. Clark, K. Minsch, S. Whiting, J. Stern, R. Hoff, B. Anderson, L. Johnston, L. Arber, and G. Blomberg, 2014. *Duwamish Blueprint: Salmon Habitat in the Duwamish Transition Zone*. Prepared by the Duwamish Blueprint Working Group for the WRIA 9 Watershed Ecosystem Forum.
- Palermo, M.R., J.H. Homziak, and A.M. Teeter, 1990. *Evaluation of Clamshell Dredging and Barge Overflow, Military Ocean Terminal, Sunny Point, North Carolina*. U.S. Army Corps of Engineers Waterways Experiment Station. March 1990.
- PFMC (Pacific Fishery Management Council), 2022a. *Pacific Coast Salmon Fishery Management Plan*. December 2022. Available at: <https://www.pcouncil.org/documents/2022/12/pacific-coast-salmon-fmp.pdf/>.
- PFMC, 2022b. *Groundfish Fishery Management Plan*. August 2022. Available at: <https://www.pcouncil.org/documents/2022/08/pacific-coast-groundfish-fishery-management-plan.pdf/>.
- Port of Seattle, 2022. *T-5 Dredge Monitoring Hydroacoustic Monitoring Report*. Prepared by Grette Associates, LLC. May 2022.

- R2 (R2 Resource Consultants, Inc.), 2014. *Lower Green/Duwamish River Habitat Assessment*. Prepared for WRIA 9 Implementation Technical Committee. April 2014. Available at: <https://www.govlink.org/watersheds/9/pdf/LowerGreen-DuwamishRiverHabitatAssessment2014.pdf>.
- Rich, A, 2010. *Potential Impacts of Re-Suspended Sediments Associated with Dredging and Dredged Material Placement on Fishes in San Francisco Bay, California: Literature Review and Identification of Data Gaps*. Prepared for the U.S. Army Corps of Engineers, San Francisco, California. July 10, 2010. Available at: https://www.spn.usace.army.mil/Portals/68/docs/Dredging/LMTS/S%20and%20S/7%20-%20LTMS%20Literature%20Review__Effects%20of%20Resuspended%20Sediments.pdf.
- Ross, P.M., G.M. Ellis, M.G. Ikononou, L.G. Barrett Lennard, and R.F. Addison, 2000. "High PCB Concentrations in Free-Ranging Pacific Killer Whales, *Orcinus orca*: Effects of Age, Sex and Dietary Preference." *Marine Pollution Bulletin* 40(6):504–515.
- Ruggerone, G.T., and D.E. Weitkamp, 2004. *WRIA 9 Chinook Salmon Research Framework: Identifying Key Research Questions about Chinook Salmon Life Histories and Habitat Use in the Middle and Lower Green River, Duwamish Waterway, and Marine Nearshore Areas*. Prepared for the WRIA 9 Steering Committee.
- Ruggerone, G.T., T.S. Nelson, J. Hall, and E. Jeanes, 2005. *2005 Juvenile Chinook Duwamish River Studies—Habitat Utilization, Migration Timing, Growth, and Diet of Juvenile Chinook Salmon in the Duwamish River and Estuary*. Prepared for WRIA 9 Technical Committee and Steering Committee. Prepared by Natural Resources Consultants, King County, City of Seattle, and R2 Resource Consultants. Funded by King Conservation District and Salmon Recovery Funding Board. May 2006.
- Ruggerone, G.T., T.S. Nelson, J. Hall, and E. Jeanes, 2006. *Habitat Utilization, Migration Timing, Growth, and Diet of Juvenile Chinook Salmon in the Duwamish River and Estuary*. Prepared for the WRIA 9 Technical and Steering Committee.
- Seaport Planning Group, 2009. *Duwamish: Lower Duwamish River Habitat Restoration Plan, An Inventory of Port of Seattle Properties*. Prepared for Port of Seattle, January 13.
- Sedell, J.R., P.A. Bisson, F.J. Swanson, and S.V. Gregory, 1988. "What We Know About Large Trees that Fall into Streams and Rivers." *From the Forest to the Sea, a Story of Fallen Trees*. Editors, C. Maser, R.R. Tarrant, J.M. Trappe, and J.F. Franklin. USDA Forest Service General Technical Report GTR-PNW-229, Pacific Northwest Research Station; pp. 83–112.

- Simenstad, C.A., editor, 1988. *Effects of Dredging on Anadromous Pacific Coast Fishes: Workshop Proceedings, Seattle, September 8–9, 1988*. Seattle: University of Washington.
- Smith, J.M., J.D. Phipps, E.D. Scermer, and D.F. Samuelson, 1976. "Impact of Dredging on Water Quality in Grays Harbor, Washington." Editors, P.A. Krekel; J. Harrison; and J.C. Burdick, III. *Specialty Conference on Dredging and Its Environmental Effects, American Society of Civil Engineers*; pp. 512–528.
- Smith, D.W., T.E. Prinslow, E.O. Salo, R.A. Campbell, and B.P. Snyder, 1979. *Trident Dredging Study: the Effects of Dredging at the U.S. Naval Submarine Base at Bangor on Outmigrating Juvenile Chum Salmon in Hood Canal, WA*. Fisheries Research Institute, FRI-UW-7918. College of Fisheries, University of Washington.
- Stehr, C.M., D.W. Brown, T. Hom, B.F. Anulacion, W.L. Reichert, and T.K. Collier, 2000. "Exposure of Juvenile Chinook and Chum Salmon to Chemical Contaminants in the Hylebos Waterway of Commencement Bay, Tacoma, Washington." *Journal of Aquatic Ecosystem Stress and Recovery* 7:215–227.
- Southard, S.L., R.M. Thom, G.D. Williams, J.D. Toft, C.W. May, G.A. McMichael, J.A. Vucelick, J.T. Newell, and J.A. Southard, 2006. *Impacts of Ferry Terminals on Juvenile Salmon Movement Along Puget Sound Shorelines*. Prepared for Washington State Department of Transportation, Report Number WA-RD-648. Available at <http://www.wsdot.wa.gov/research/reports/fullreports/648.1.pdf>.
- SWIFD (Statewide Washington Integrated Fish Distribution), 2022. "Web Mapper." Accessed October 27, 2022. Available at: <https://geo.nwifc.org/swifd/>.
- Tiffan, K.F., L.O. Clark, R.D. Garland, and D.W. Rondorf, 2006. "Variables Influencing the Presence of Subyearling Fall Chinook Salmon in Shoreline Habitats of the Hanford Reach, Columbia River." *North American Journal of Fisheries Management* 26:351–360.
- Thackston, E.L., and M.R. Palermo, 2000. *Improved Methods for Correlating Turbidity and Suspended Solids for Monitoring*. U.S. Army Corps of Engineers Research and Development Center, DOER Technical Notes. Available at: <http://el.erdc.usace.army.mil/pubs/pdf/doere8.pdf>.
- USACE (U.S. Army Corps of Engineers), 1982. *Water Quality Effects of Hopper Dredging on Isthmus Slough During Late Summer Temperature Regimes*. Portland, Oregon. 26 pp.
- USACE, 2008. *Technical Guidelines for Environmental Dredging of Contaminated Sediments*. Technical Report ERDC/EL TR-08-29. U.S. Army Engineer Research and Development Center. September 2008.

USACE, 2015. *Dredging and Dredged Material Management*. Engineer Manual. U.S. Army Corps of Engineers Engineering and Design. EM 1110-2-5025. July 2015.

USFWS (U.S. Fish and Wildlife Service), 1997. *Recovery Plan for the Threatened Marbled Murrelet (Washington, Oregon and California Populations)*. Region 1.

USFWS, 2012. *Guidance for Identifying Marbled Murrelet Nest Trees in Washington State*. April 2012. Available at: <https://wsdot.wa.gov/sites/default/files/2021-10/Env-FW-MAMU-Habitat-FWS.pdf>.

USFWS, 2015. *Coastal Recovery Unit Implementation Plan for Bull Trout (Salvelinus confluentus)*. September 2015. Available at: <https://www.seattle.gov/light/skagit/Relicensing/cs/groups/secure/@scl.skagit.team/documents/document/cm9k/ndy1/~edisp/prod465588.pdf>.

USFWS, 2017. *Biological Opinion*. Regional General Permit 6: Structures in Inland Marine Waters in Washington State (RGP-6) Clallam, Jefferson, Island, King, Kitsap, Mason, Pierce, San Juan, Skagit, Snohomish, Thurston, and Whatcom Counties, Washington. January 2017. Available at <https://www.nws.usace.army.mil/Portals/27/docs/regulatory/RGPs/RGP6/01EWF00-2016-F-0565.pdf?ver=2017-02-07-231906-177>.

USFWS, 2022a. "Information for Planning and Consultation (IPaC) Web Mapper." Accessed October 14, 2022. Available at: <https://ipac.ecosphere.fws.gov>.

USFWS, 2022b. "Species Profile for Bull Trout." Accessed October 20, 2022. Available at: <https://ecos.fws.gov/ecp/species/8212>.

Van Oostrum, R.W., and P. Vroege, 1994. "Turbidity and Contaminant Release During Dredging of Contaminated Sediments." *Proceedings of the Second International Conference on Dredging and Dredge Material Placement, Dredging '94*.

Vigil, R., 2023. Email to Merri Martz, Julia Fitts, Sara Noland (Anchor QEA, LLC), and Jenna Harlacher (NOAA Affiliate). March 28, 2023, forwarding information on the sunflower sea star from Greg Balogh, NOAA; email dated March 23, 2023.

- Wang, T., K. Larm, and D. Hotchkiss, 2003. "Evaluation of Closed Buckets for Remedial Dredging and Case Histories." *Dredging '02: Key Technologies for Global Prosperity, Third Specialty Conference on Dredging and Dredged Material Disposal*. Orlando, Florida. Available at: [https://ascelibrary.org/doi/abs/10.1061/40680\(2003\)141](https://ascelibrary.org/doi/abs/10.1061/40680(2003)141).
- WDFW (Washington Department of Fish and Wildlife), 2011. *Puget Sound Steelhead Foundations: A Primer for Recovery Planning*. December 2011. Available at: <https://wdfw.wa.gov/sites/default/files/publications/01512/wdfw01512.pdf>.
- WDFW, 2022a. "Yellow-Billed Cuckoo." Accessed October 28, 2022. Available at <https://wdfw.wa.gov/species-habitats/species/coccyzus-americanus#desc-range>.
- WDFW, 2022b. "Wolverine." Accessed October 28, 2022. Available at: <https://wdfw.wa.gov/species-habitats/species/gulo-gulo-luscus#desc-range>.
- Weitkamp, D., and G.T. Ruggerone, 2000. *Factors Influencing Chinook Salmon Populations in Proximity to the City Of Seattle*. Prepared for the City of Seattle by Parametrix, Natural Resources Consultants, and Cedar River Associates.
- White, R.D., D. Shea, and J.J. Stegeman, 1997. "Metabolism of the Aryl Hydrocarbon Receptor Agonist 3,3',4,4'-tetrachlorobiphenyl by the Marine Fish Scup (*Stenotomus chrysops*) in Vivo and in Vitro." *Drug Metabolism and Disposition* 25(5):564–72.
- Williams, G.D., R.M. Thom, D.K. Shreffler, J.A. Southard, L.K. O'Rourke, S.L. Sargeant, V.I. Cullinan, R. Moursund, and M. Stamey, 2003. *Assessing Overwater Structure-Related Predation Risk on Juvenile Salmon: Field Observations and Recommended Protocols*. Prepared for the Washington State Department of Transportation, Under a Related Services Agreement with the U.S. Department of Energy Under Contract DE-AC06-76RLO 1830. Pacific Northwest National Laboratory.
- Williams, R.W., R.M. Laramie, and J.J. James, 1975. *A Catalog of Washington Streams and Salmon Utilization*. Volume 1 – Puget Sound. Washington Department of Fisheries.
- Windward (Windward Environmental, LLC), 2004. *Lower Duwamish Waterway Remedial Investigation*. Intertidal Clam Survey Data Report. Prepared for Lower Duwamish Waterway Group.
- Windward, 2010. *Final Lower Duwamish Waterway Remedial Investigation*. Submitted to U.S. Environmental Protection Agency and Washington State Department of Ecology. July 9, 2010.
- Windward, 2020. *Lower Duwamish Waterway Pre-Design Studies Data Evaluation Report*. Prepared for Lower Duwamish Waterway Group. June 2020.

- WRIA 9 (WRIA 9 Coordination Team), 2015. *Implementation Progress Report 2005–2014, WRIA 9 Salmon Habitat Plan: Making our Watershed Fit for a King*. Green/Duwamish and Central Puget Sound Watershed. March 2015. Available at:
https://www.govlink.org/watersheds/9/plan-implementation/ProgressReport2015/1503_4553L_W9progReport_Main.pdf.
- WRIA 9, 2021. *Salmon Habitat Plan 2021 Update*. Green/Duwamish and Central Puget Sound Watershed. February 2021. Available at:
https://www.govlink.org/watersheds/9/pdf/2021_PlanUpdate.pdf.
- Wright, T.D., 1978. "Aquatic Dredged Material Disposal Impacts." *Synthesis of Research Results, Dredged Material Research Program*. Technical Report DS-78-1, U. S. Army Engineer Waterways Experiment Station Environmental Laboratory.
- WSDOT (Washington State Department of Transportation), 2021. *Biological Assessment Preparation Manual*. Accessed October 19, 2022. Available at: <https://wsdot.wa.gov/engineering-standards/environmental-guidance/endangered-species-act-essential-fish-habitat>.
- Wydoski, R.S., and R.R. Whitney, 2003. *Inland Fishes of Washington*. Seattle: University of Washington Press; p. 322.

Figures

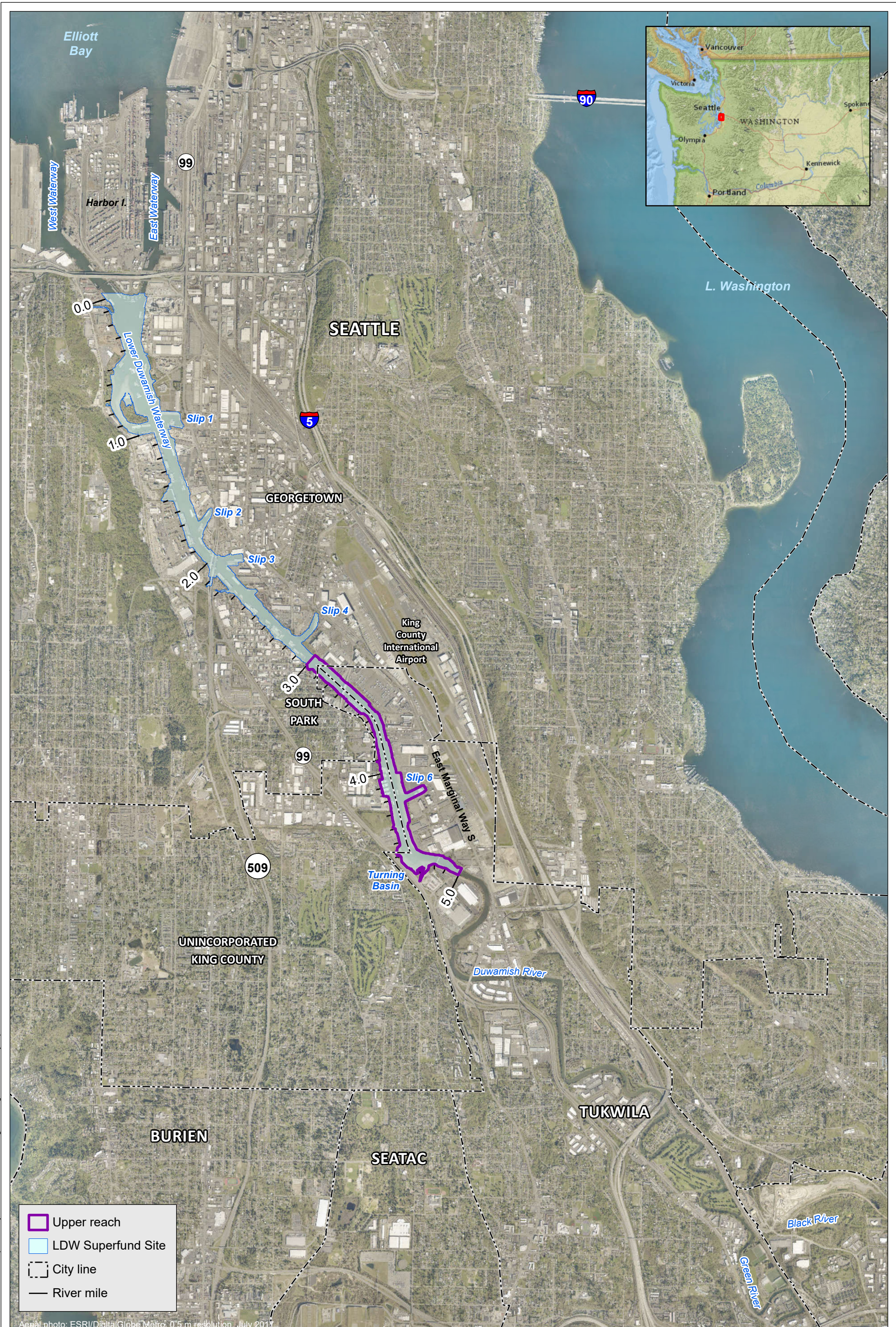

- Upper reach
- LDW Superfund Site
- City line
- River mile

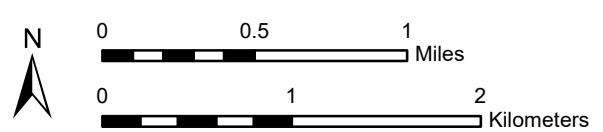
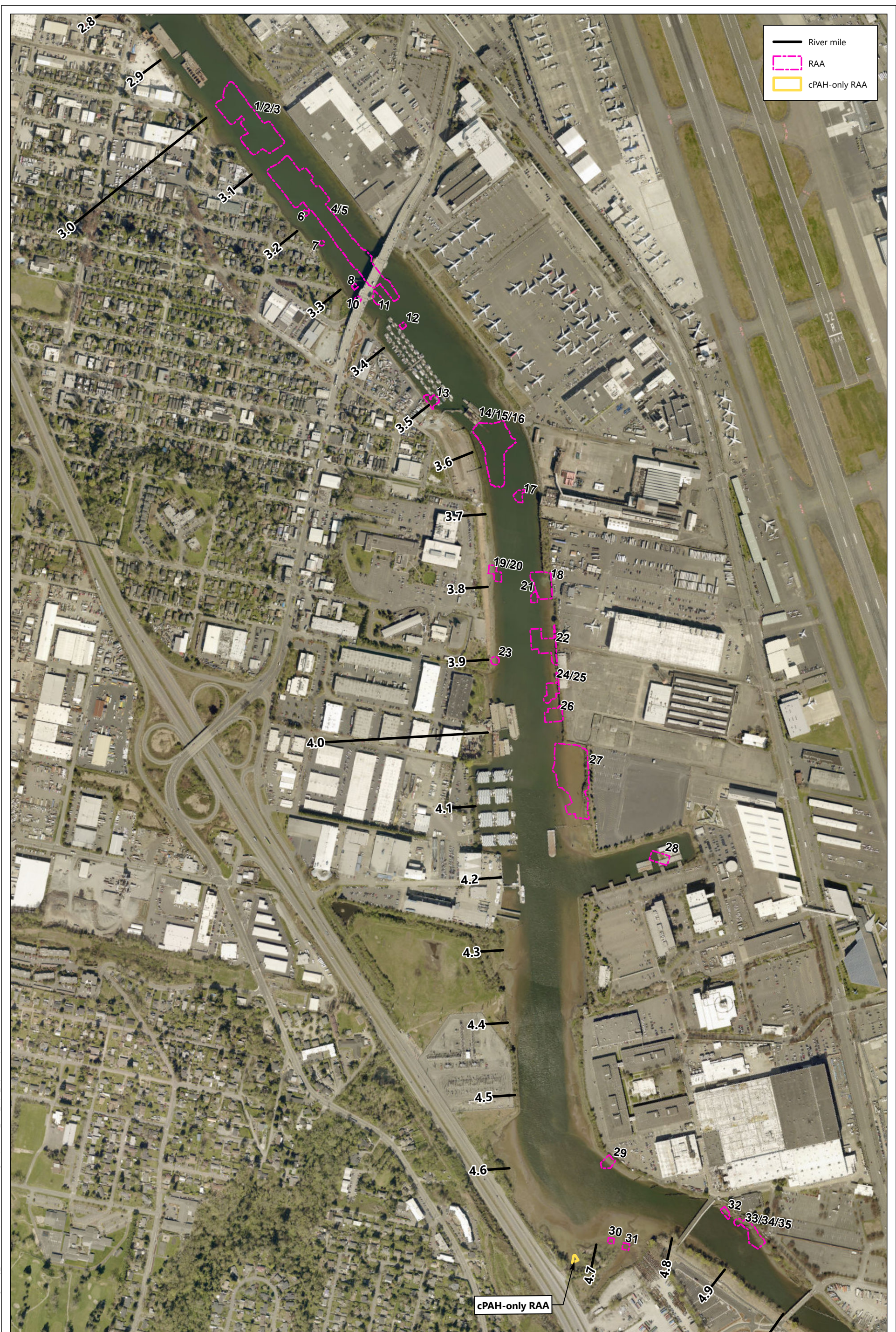

Figure E1-1. LDW Superfund Site vicinity map and identification of upper reach

**90% REMEDIAL DESIGN
BASIS OF DESIGN REPORT
FOR THE LDW UPPER REACH**

JULY 24, 2023

Prepared by crgah, 1/25/23, W:\Projects\Duwamish_AOC4\GIS\Maps and Analyses\Phase III\60_Percent\Design\BODR\Fig 02-1 7059_Vicinity map.mxd



River mile
 RAA
 cPAH-only RAA

cPAH-only RAA

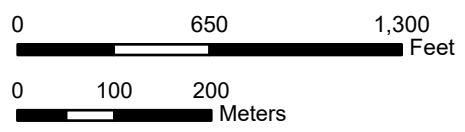

Lower Duwamish Waterway Group
 Port of Seattle / City of Seattle / King County / The Boeing Company

Figure E2-1. Remedial action areas within the upper reach

90% REMEDIAL DESIGN
 BASIS OF DESIGN REPORT
 FOR THE LDW UPPER REACH

JULY 24, 2023

Prepared by Ilanson, 5/24/2023, \\nrcas\GIS\Jobs\KingCounty_0067\LDW\Maps\Reports\BasisDesign\Report\LDW_BDR_90pct_AppendixE.aprx

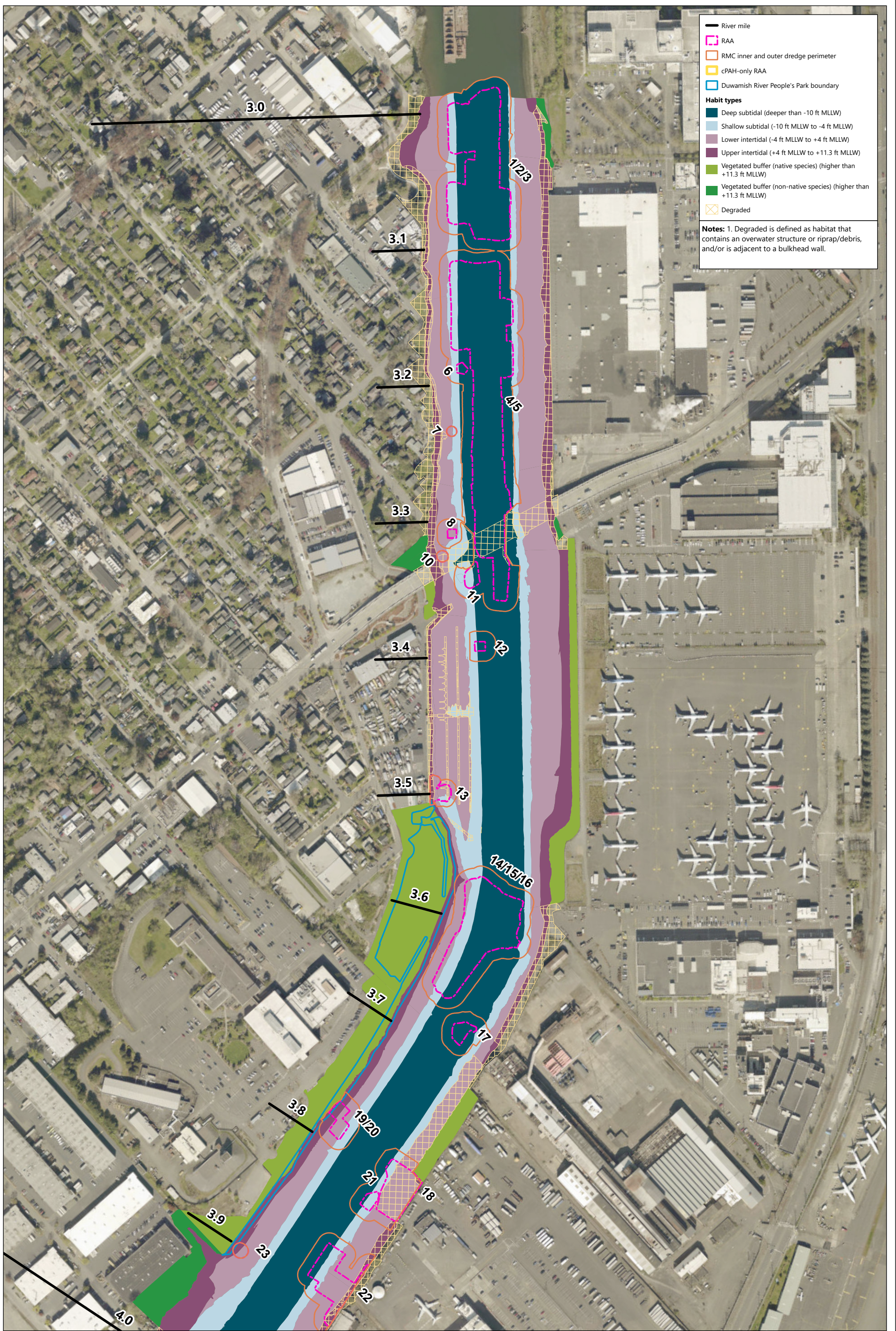

— River mile
 ■ RAA
 ■ RMC inner and outer dredge perimeter
 ■ cPAH-only RAA
 ■ Duwamish River People's Park boundary
Habit types
 ■ Deep subtidal (deeper than -10 ft MLLW)
 ■ Shallow subtidal (-10 ft MLLW to -4 ft MLLW)
 ■ Lower intertidal (-4 ft MLLW to +4 ft MLLW)
 ■ Upper intertidal (+4 ft MLLW to +11.3 ft MLLW)
 ■ Vegetated buffer (native species) (higher than +11.3 ft MLLW)
 ■ Vegetated buffer (non-native species) (higher than +11.3 ft MLLW)
 ■ Degraded
Notes: 1. Degraded is defined as habitat that contains an overwater structure or riprap/debris, and/or is adjacent to a bulkhead wall.

Prepared by JIanson, 5/24/2023, \\nrcas\GIS\Jobs\KingCounty_0067\LDW\Maps\Reports\BasisDesign\Report\LDW_BDR_90pct_AppendixE.aprx

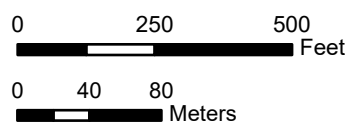
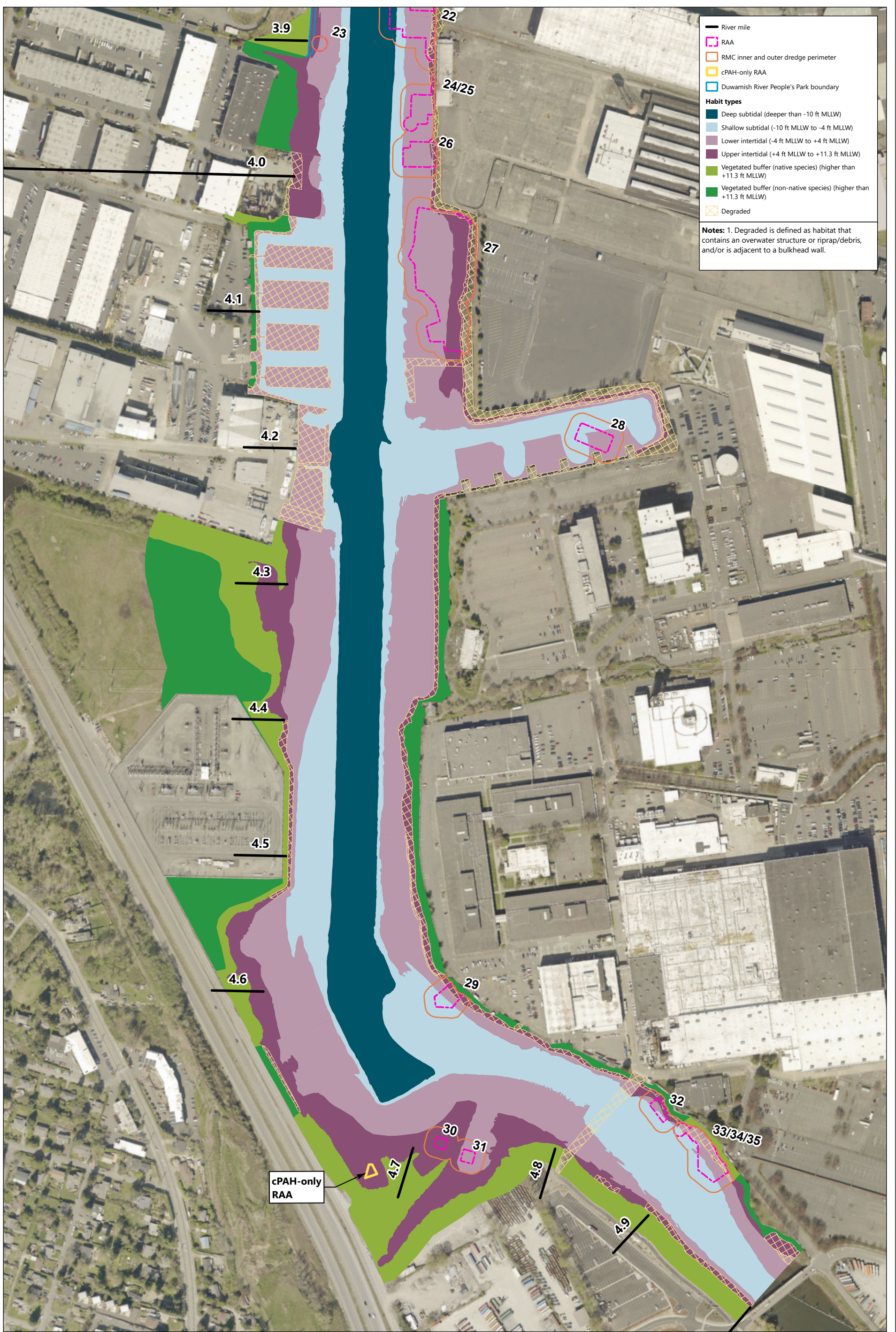

Figure E2-2a. Existing habitat conditions and remedial action areas within the upper reach
 90% REMEDIAL DESIGN BASIS OF DESIGN REPORT FOR THE LDW UPPER REACH
 JULY 24, 2023



— River mile
 ■ RAA
 ■ RMC inner and outer dredge perimeter
 ■ cPAH-only RAA
 ■ Duwamish River People's Park boundary
Habit types
 ■ Deep subtidal (deeper than -10 ft MLLW)
 ■ Shallow subtidal (-10 ft MLLW to -4 ft MLLW)
 ■ Lower intertidal (-4 ft MLLW to +4 ft MLLW)
 ■ Upper intertidal (+4 ft MLLW to +11.3 ft MLLW)
 ■ Vegetated buffer (native species) (higher than +11.3 ft MLLW)
 ■ Vegetated buffer (non-native species) (higher than +11.3 ft MLLW)
 ■ Degraded

Notes: 1. Degraded is defined as habitat that contains an overwater structure or riprap/debris, and/or is adjacent to a bulkhead wall.

cPAH-only RAA

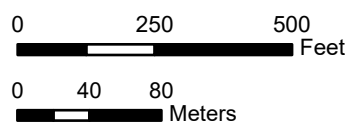

Prepared by JIanson, 5/24/2023, \\nrcas\GIS\Jobs\KingCounty_0067\LDW\Maps\Reports\BasisDesign\Report\LDW_BDR_90pct_AppendixE.aprx

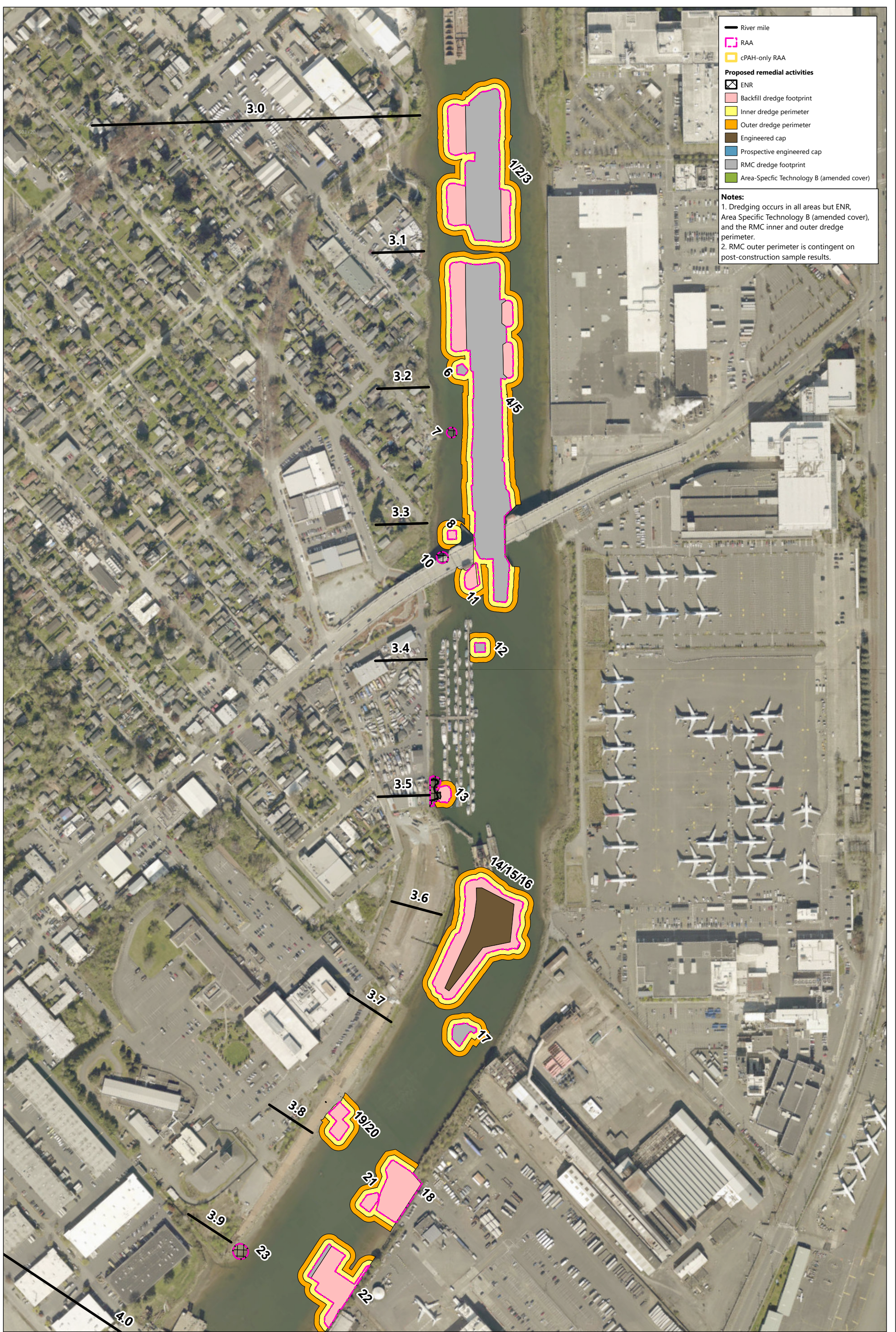

— River mile
 ■ RAA
 ■ cPAH-only RAA
Proposed remedial activities
 ■ ENR
 ■ Backfill dredge footprint
 ■ Inner dredge perimeter
 ■ Outer dredge perimeter
 ■ Engineered cap
 ■ Prospective engineered cap
 ■ RMC dredge footprint
 ■ Area-Specific Technology B (amended cover)

Notes:
 1. Dredging occurs in all areas but ENR, Area Specific Technology B (amended cover), and the RMC inner and outer dredge perimeter.
 2. RMC outer perimeter is contingent on post-construction sample results.

Prepared by JIanson, 5/24/2023, \\nrcas\GIS\Jobs\KingCounty_0067\LDW\Maps\Reports\BasisDesign\Report\LDW_BDR_90pct_AppendixE.aprx

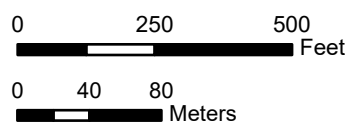
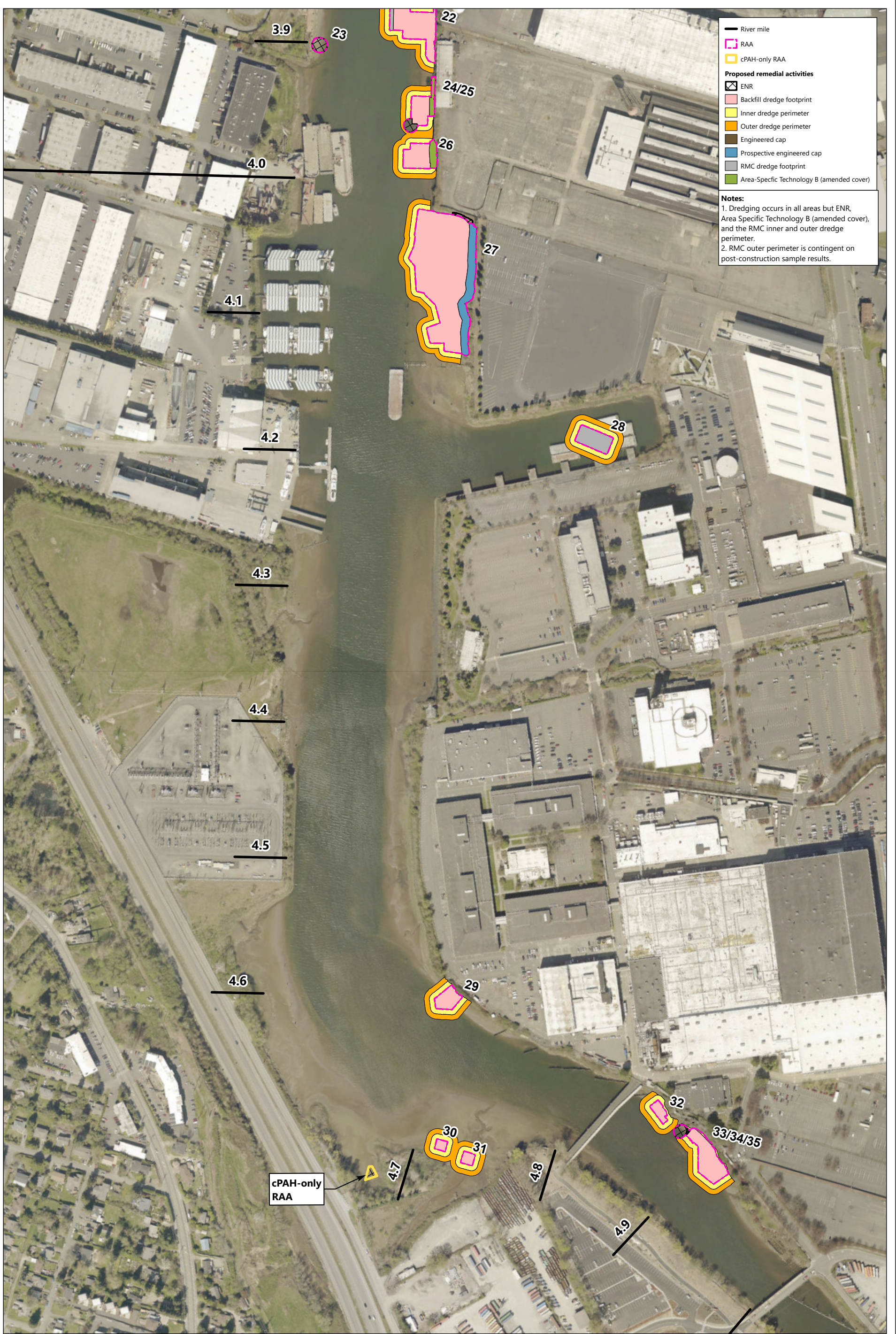

Figure E2-3a. Proposed remedial activities by remedial action area
 90% REMEDIAL DESIGN BASIS OF DESIGN REPORT FOR THE LDW UPPER REACH
 JULY 24, 2023



— River mile
 ■ RAA
 ■ cPAH-only RAA

Proposed remedial activities

- ⊠ ENR
- Backfill dredge footprint
- Inner dredge perimeter
- Outer dredge perimeter
- Engineered cap
- Prospective engineered cap
- RMC dredge footprint
- Area-Specific Technology B (amended cover)

Notes:

1. Dredging occurs in all areas but ENR, Area Specific Technology B (amended cover), and the RMC inner and outer dredge perimeter.
2. RMC outer perimeter is contingent on post-construction sample results.

Prepared by JIanson, 5/24/2023, I:\cra\GIS\Jobs\KingCounty_0067\LDW\Maps\Reports\BasisDesign\Report\LDW_BDR_90pct_AppendixE.aprx

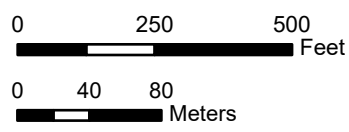

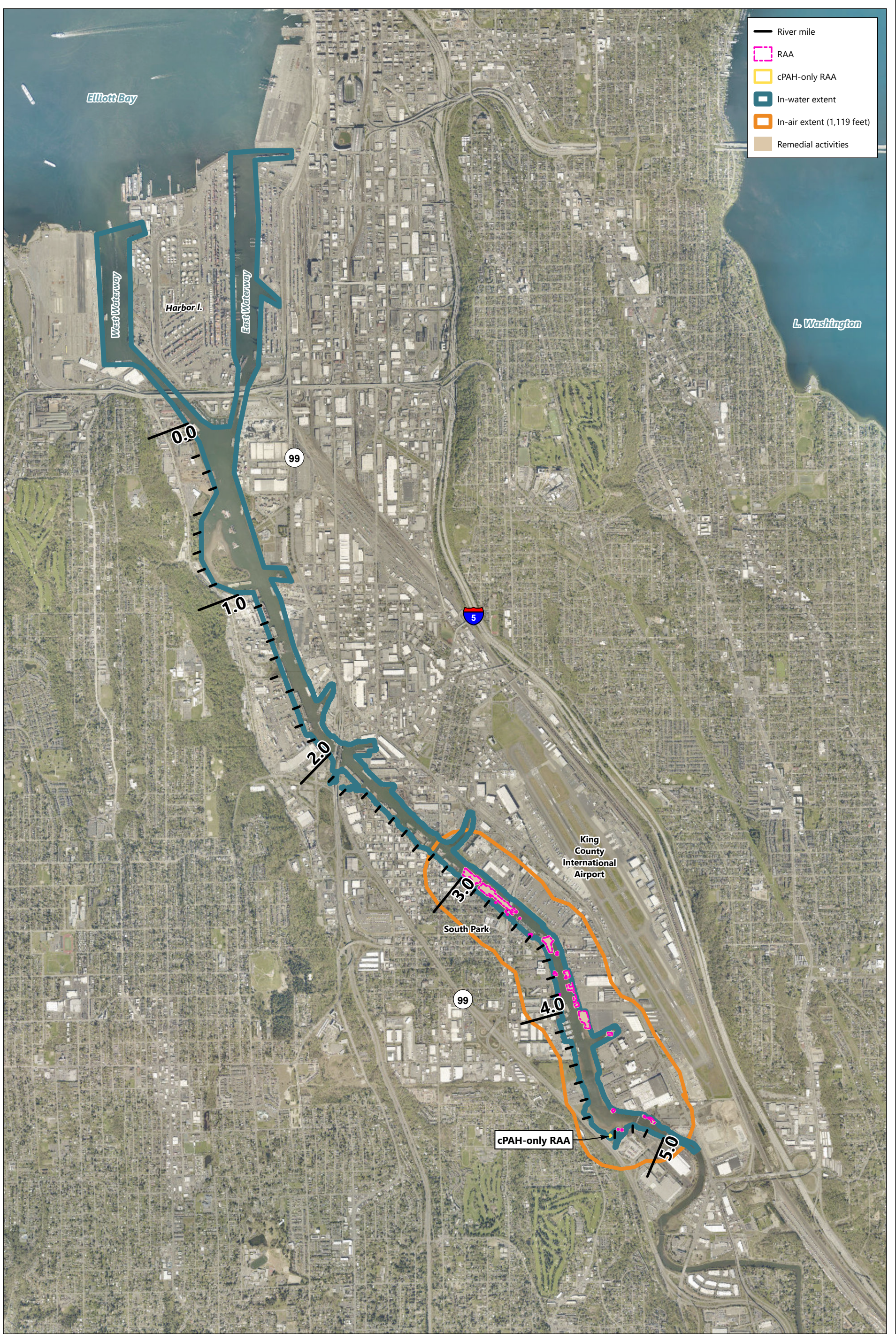

Prepared by Ilanson, 5/24/2023, \\nrcas\GIS\Jobs\KingCounty_0067\LDW\Maps\Reports\BasisDesign\Report\LDW_BDR_90pct_AppendixE.aprx



Lower Duwamish Waterway Group
 Port of Seattle / City of Seattle / King County / The Boeing Company

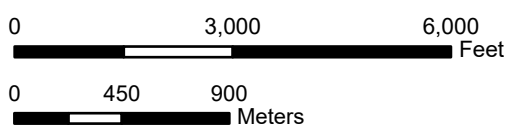
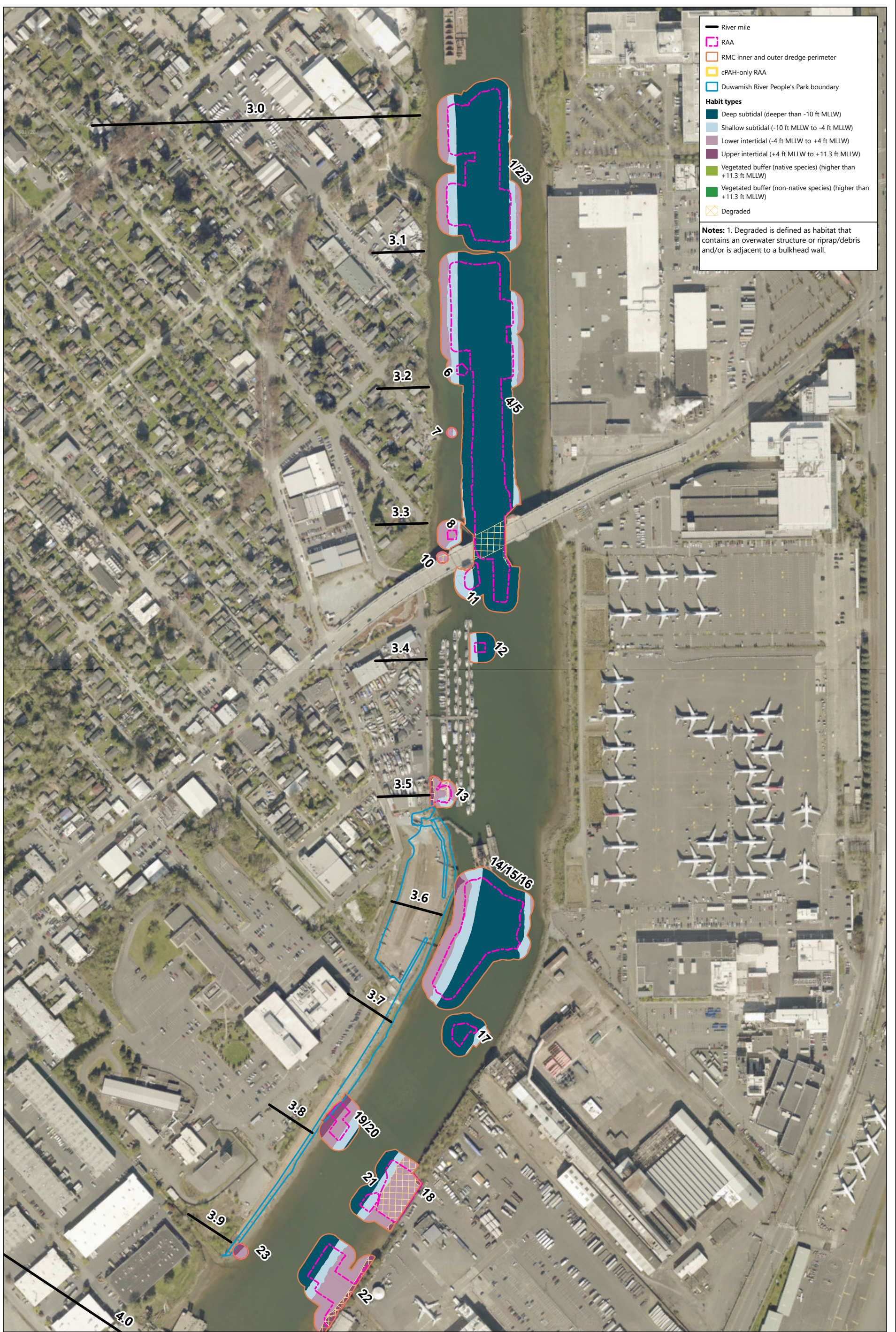

Figure E3-1. Action area

90% REMEDIAL DESIGN
 BASIS OF DESIGN REPORT
 FOR THE LDW UPPER REACH

JULY 24, 2023



— River mile
 ■ RAA
 ■ RMC inner and outer dredge perimeter
 ■ cPAH-only RAA
 ■ Duwamish River People's Park boundary
Habit types
 ■ Deep subtidal (deeper than -10 ft MLLW)
 ■ Shallow subtidal (-10 ft MLLW to -4 ft MLLW)
 ■ Lower intertidal (-4 ft MLLW to +4 ft MLLW)
 ■ Upper intertidal (+4 ft MLLW to +11.3 ft MLLW)
 ■ Vegetated buffer (native species) (higher than +11.3 ft MLLW)
 ■ Vegetated buffer (non-native species) (higher than +11.3 ft MLLW)
 ■ Degraded

Notes: 1. Degraded is defined as habitat that contains an overwater structure or riprap/debris and/or is adjacent to a bulkhead wall.

Prepared by Ilanson, 5/24/2023, \\nrcas\GIS\Jobs\KingCounty_0067\LDW\Maps\Reports\BasisDesign\Report\LDW_BDR_90pct_AppendixE.aprx

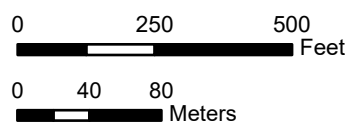

Figure E4-1a. Existing habitat conditions within the remedial action areas
 90% REMEDIAL DESIGN BASIS OF DESIGN REPORT FOR THE LDW UPPER REACH
 JULY 24, 2023



— River mile
 [Pink outline] RAA
 [Orange outline] RMC inner and outer dredge perimeter
 [Yellow outline] cPAH-only RAA
 [Blue outline] Duwamish River People's Park boundary
Habit types
 [Dark blue] Deep subtidal (deeper than -10 ft MLLW)
 [Light blue] Shallow subtidal (-10 ft MLLW to -4 ft MLLW)
 [Medium blue] Lower intertidal (-4 ft MLLW to +4 ft MLLW)
 [Purple] Upper intertidal (+4 ft MLLW to +11.3 ft MLLW)
 [Green] Vegetated buffer (native species) (higher than +11.3 ft MLLW)
 [Light green] Vegetated buffer (non-native species) (higher than +11.3 ft MLLW)
 [Yellow with X] Degraded

Notes: 1. Degraded is defined as habitat that contains an overwater structure or riprap/debris and/or is adjacent to a bulkhead wall.

cPAH-only RAA

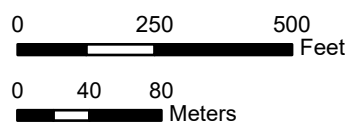

Prepared by JIanson, 5/24/2023, \\nrcas\GIS\Jobs\KingCounty_0067\LDW\Maps\Reports\BasisDesign\Report\LDW_BDR_90pct_AppendixE.aprx

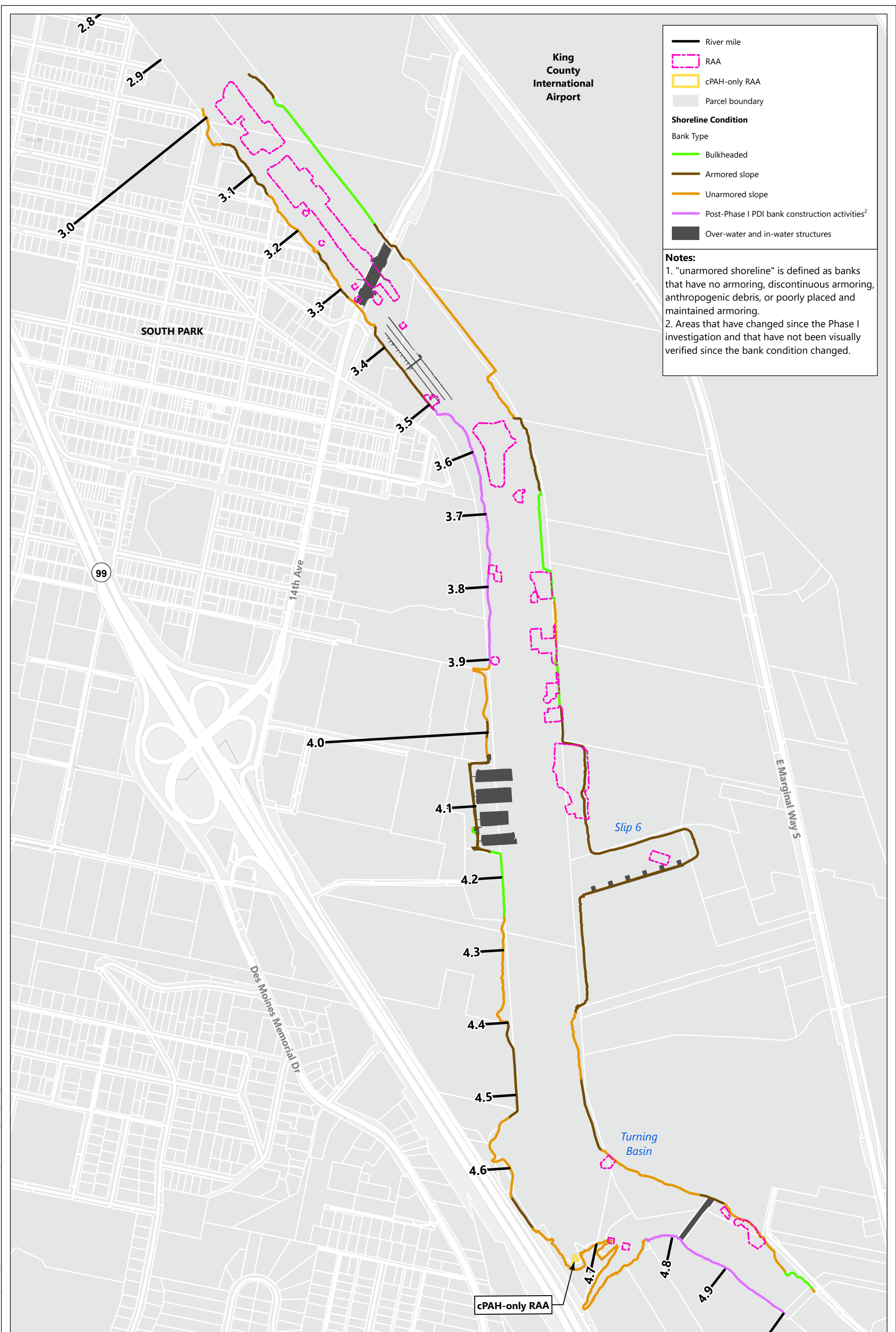

Prepared by JIanson, 5/24/2023, \\nrcas\GIS\Jobs\KingCounty_0067\LDW\Maps\Reports\BasisDesign\Report\LDW_BDR_90pct_AppendixE.aprx

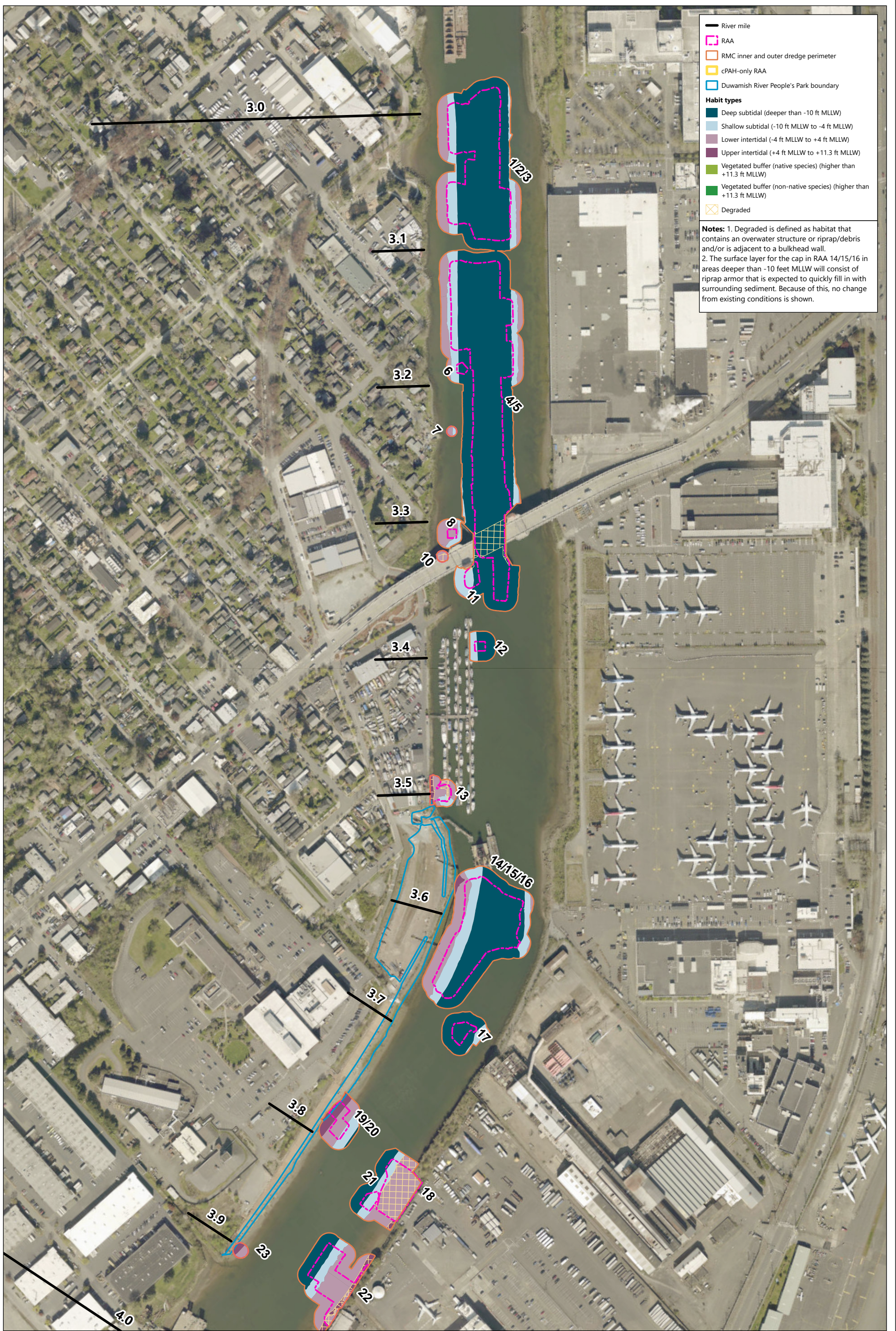

Legend

- River mile
- RAA
- RMC inner and outer dredge perimeter
- cPAH-only RAA
- Duwamish River People's Park boundary

Habit types

- Deep subtidal (deeper than -10 ft MLLW)
- Shallow subtidal (-10 ft MLLW to -4 ft MLLW)
- Lower intertidal (-4 ft MLLW to +4 ft MLLW)
- Upper intertidal (+4 ft MLLW to +11.3 ft MLLW)
- Vegetated buffer (native species) (higher than +11.3 ft MLLW)
- Vegetated buffer (non-native species) (higher than +11.3 ft MLLW)
- Degraded

Notes:

1. Degraded is defined as habitat that contains an overwater structure or riprap/debris and/or is adjacent to a bulkhead wall.
2. The surface layer for the cap in RAA 14/15/16 in areas deeper than -10 feet MLLW will consist of riprap armor that is expected to quickly fill in with surrounding sediment. Because of this, no change from existing conditions is shown.

Prepared by JIanson, 5/24/2023, \\nrcas\GIS\Jobs\KingCounty_0067\LDW\Maps\Reports\BasisDesign\Report\LDW_BDR_90pct_AppendixE.aprx

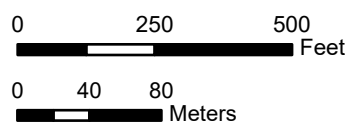
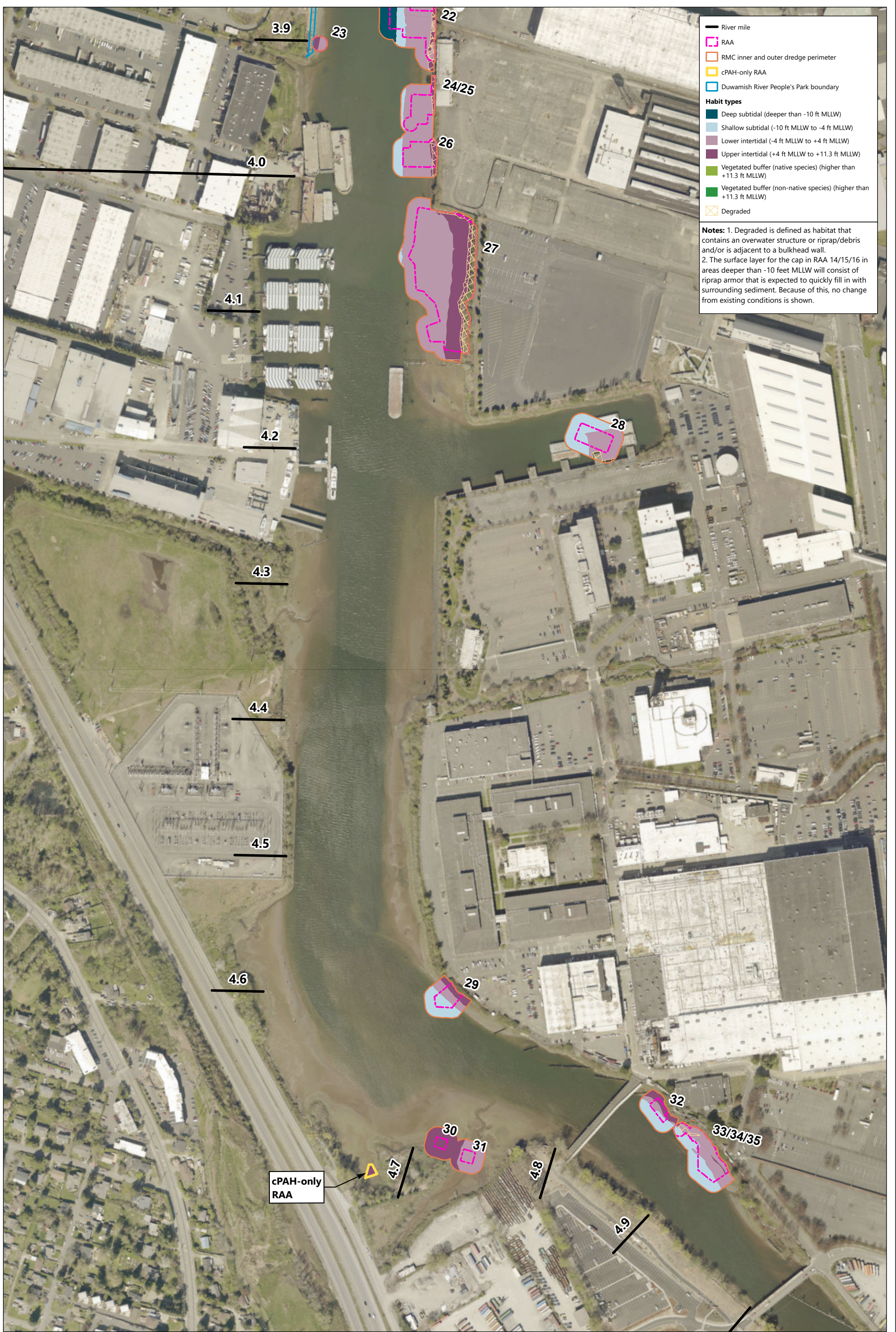

Figure E6-1a. Post construction habitat conditions within the remedial action areas

90% REMEDIAL DESIGN
 BASIS OF DESIGN REPORT
 FOR THE LDW UPPER REACH

JULY 24, 2023



Prepared by JIanson, 5/24/2023, \\nrcas\GIS\Jobs\KingCounty_0067\LDW\Maps\Reports\BasisDesign\Report\LDW_BDR_90pct_AppendixE.aprx

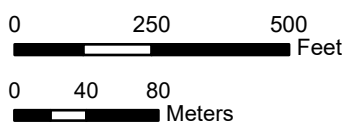

Figure E6-1b. Post construction habitat conditions within the remedial action areas

Attachment E.1

Remedial Action Area Photographs

Photographs of Shoreline Conditions

Background

This attachment shows the existing shoreline conditions within or adjacent to remedial action areas (RAAs) within the upper reach of the Lower Duwamish Waterway Superfund Site in King County, Washington. The photographs included primarily show shallow subtidal, lower intertidal, upper intertidal, and adjacent buffer habitat. Deep subtidal habitat may also be present in some photos; however, RAAs that include only subtidal habitat in the federal navigation channel were not included. Habitats are considered degraded when overwater structures, riprap or armor, debris, or bulkheads are present. Degraded buffer includes vegetation that occurs within or near a bulkhead or armored slope. Upper intertidal habitat is classified as degraded if adjacent to a bulkhead wall, as described in Attachment F, *Habitat Evaluation*, of the *Biological Assessment for the Lower Duwamish Waterway*.

Photographs taken during Phase I bank visual inspection (June 2020; Anchor QEA and Windward 2022, Appendix E) and Phase II visual inspection of shoreline vegetation (June and July 2021; Anchor QEA and Windward 2022, Appendix I) in the following RAAs are included:

FIGURES

Figure E.1-1	RAA 7, Between RM 3.2 and RM 3.3	1
Figure E.1-2	RAA 8, Between RM 3.3 and RM 3.4	2
Figure E.1-3	RAA 10, Between RM 3.3 and RM 3.4	3
Figure E.1-4	RAA 13, RM 3.5	4
Figure E.1-5	RAA 15–16, Between RM 3.6 and RM 3.7	5
Figure E.1-6	RAA 18, RM 3.8	6
Figure E.1-7	RAA 19–20, Between RM 3.7 and RM 3.8	7
Figure E.1-8	RAA 22, Between RM 3.8 and RM 3.9	8
Figure E.1-9	RAA 23, RM 3.9	9
Figure E.1-10	RAA 24, Between RM 3.9 and RM 4.0	10
Figure E.1-11	RAA 25, Between RM 3.9 and RM 4.0	11
Figure E.1-12	RAA 26, Between RM 3.9 and RM 4.0	12
Figure E.1-13	RAA 27, Between RM 4.0 and RM 4.1	13
Figure E.1-14	RAA 28, RM 4.2	14
Figure E.1-15	RAA 29, Between RM 4.6 and RM 4.7	15
Figure E.1-16	RAA 30, Between RM 4.7 and RM 4.8	16
Figure E.1-17	RAA 31, Between RM 4.7 and RM 4.8	17
Figure E.1-18	RAA 32, Between RM 4.8 and RM 4.9	18

Figure E.1-19 RAA 33, Between RM 4.8 and RM 4.9 19
Figure E.1-20 RAA 34–35, Between RM 4.8 and RM 5.0..... 20

Photographs

Figure E.1-1
RAA 7, Between RM 3.2 and RM 3.3



Photograph A: Phase I, West Bank



Photograph B: Phase I, West Bank

Figure E.1-2
RAA 8, Between RM 3.3 and RM 3.4



Photograph A: Phase I, West Bank



Photograph B: Phase I, West Bank

Figure E.1-3
RAA 10, Between RM 3.3 and RM 3.4



Photograph: Phase I, West Bank

Figure E.1-4
RAA 13, RM 3.5



Photograph A: Phase II, West Bank



Photograph B: Phase I, West Bank



Photograph C: Phase I, West Bank



Photograph D: Phase I, West Bank

Figure E.1-5
RAA 15-16, Between RM 3.6 and RM 3.7



Photograph A: Phase III, East Bank



Photograph B: Phase III, East Bank



Photograph C: Phase III, East Bank



Photograph D: Phase III, East Bank

Figure E.1-6
RAA 18, RM 3.8



Photograph A: Phase II, East Bank



Photograph B: Phase II, East Bank



Photograph C: Phase I, East Bank



Photograph D: Phase I, East Bank

Figure E.1-7
RAA 19–20, Between RM 3.7 and RM 3.8



Photograph A: Phase III, West Bank



Photograph B: Phase III, West Bank



Photograph C: Phase III, West Bank



Photograph D: Phase III, West Bank

Figure E.1-8
RAA 22, Between RM 3.8 and RM 3.9



Photograph A: Phase II, East Bank



Photograph B: Phase I, East Bank



Photograph C: Phase I, East Bank



Photograph D: Phase I, East Bank

Figure E.1-9
RAA 23, RM 3.9



Photograph A: Phase III, West Bank



Photograph B: Phase III, West Bank



Photograph C: Phase III, West Bank



Photograph D: Phase III, West Bank

Figure E.1-10
RAA 24, Between RM 3.9 and RM 4.0



Photograph A: Phase I, East Bank



Photograph B: Phase I, East Bank

Figure E.1-11
RAA 25, Between RM 3.9 and RM 4.0



Photograph: Phase I, East Bank

Figure E.1-12
RAA 26, Between RM 3.9 and RM 4.0



Photograph A: Phase I, East Bank



Photograph B: Phase I, East Bank

Figure E.1-13
RAA 27, Between RM 4.0 and RM 4.1



Photograph A: Phase II, East Bank



Photograph B: Phase I, East Bank



Photograph C: Phase I, East Bank



Photograph D: Phase I, East Bank

Figure E.1-14
RAA 28, RM 4.2



Photograph A: Phase I, East Bank



Photograph B: Phase I, East Bank



Photograph C: Phase II, East Bank



Photograph D: Phase II, East Bank

Figure E.1-15
RAA 29, Between RM 4.6 and RM 4.7



Photograph A: Phase II, East Bank



Photograph B: Phase II, East Bank



Photograph C: Phase I, East Bank

Figure E.1-16
RAA 30, Between RM 4.7 and RM 4.8



Photograph: Phase I, West Bank

Figure E.1-17
RAA 31, Between RM 4.7 and RM 4.8



Photograph A: Phase I, West Bank



Photograph B: Phase I, West Bank

Figure E.1-18
RAA 32, Between RM 4.8 and RM 4.9



Photograph A: Phase II, East Bank



Photograph B: Phase II, East Bank



Photograph C: Phase II, East Bank



Photograph D: Phase II, East Bank

Figure E.1-19
RAA 33, Between RM 4.8 and RM 4.9



Photograph A: Phase II, East Bank



Photograph B: Phase II, East Bank

Figure E.1-20
RAA 34-35, Between RM 4.8 and RM 5.0



Photograph A: Phase II, East Bank



Photograph B: Phase II, East Bank



Photograph C: Phase II, East Bank



Photograph D: Phase I, East Bank

Reference

Anchor QEA and Windward (Anchor QEA, LLC, and Windward Environmental LLC), 2022. *Pre-Design Investigation Data Evaluation Report for the Lower Duwamish Waterway – Upper Reach*. Final. July 15, 2022.

Attachment E.2

Summary of Remediation Components Table

**Table E.2-1
Summary of Remediation Components**

Action Component ¹	Where	When	Avoidance and Minimization Measures
Dredging of contaminated sediments (includes a contingency area to account for the potential that the RAA boundaries may be revised based on new Phase III PDI data)	LDW; approximately 15.2 acres total that include 0.3 acre riparian (higher than 11.3 feet MLLW), 4.9 acres intertidal (-4 to +13 feet MLLW), 1.5 acres shallow subtidal (-10 to -14 feet MLLW), and 8.5 acres deep subtidal (deeper than -10 feet MLLW).	In-water work window across three construction seasons; for each RAA, construction will only occur during one season.	<ul style="list-style-type: none"> • Conduct all in-water work within the approved in-water work window when juvenile Chinook salmon, steelhead, and bull trout are not expected to be present or are expected only in low numbers. • Implement general measures to minimize impacts (e.g., follow specific dredging procedures). See Section 2.4.2 for additional details and impact minimization measures. • Employ mechanical controls (e.g., use of environmental bucket) and operational measures (e.g., avoid overfilling bucket, reduce dredging speed) to minimize sediment disturbance and dispersion. See Section 2.4.2 for additional details and minimization measures. • Employ treatment of barge return water (e.g., filter or other treatment system of all water prior to discharge to remove suspended solids) when necessary based on water quality criteria. • Adhere to emergency spill response measures according to contractor's spill containment and control plan. • Perform monitoring of water quality standard parameters (e.g., turbidity, DO, pH, and temperature) in accordance with EPA-approved water quality monitoring plan during in-water work. • Perform water quality monitoring of project-specific COCs in accordance with EPA-approved water quality monitoring plan during in-water work. • Place suitable habitat material to return the post-dredge elevation to existing grade in all dredge areas at or shallower than -10 feet MLLW. • Cover all dredge leave surfaces in waters deeper than -10 feet MLLW with a 6- to 12-inch RMC, which is expected to consist of medium to coarse sand.
Placement of engineered capping, backfill, and RMC within the dredge footprint (includes a contingency to account for the potential that the RAA boundaries may be revised based on new Phase III PDI data)	<p>Engineered capping after dredging: LDW; 0.4 acre of (prospective) RAA 27² that includes 0.3 acre riparian and 0.1 acre intertidal, 1.0 acre over RAA 14/15/16 that is deep subtidal, plus 0.22 acre of contingency in shallow subtidal zone.</p> <p>Backfill after dredging (to existing grade): LDW in dredge areas that are currently -10 feet MLLW and shallower, over up to 7.7 acres.</p> <p>RMC (placement of a 6- to 12-inch sand layer after dredging): LDW, up to 5.9 acres total within the dredged footprint.</p>	In-water work window across three construction seasons; for each RAA, construction will only occur during one season.	<ul style="list-style-type: none"> • Conduct all in-water work within the approved in-water work window when juvenile Chinook salmon, steelhead, and bull trout are not expected to be present or are expected only in low numbers. • Implement general impact minimization measures that allow import materials to be placed in a controlled and accurate manner and that limit disturbance of the bottom sediments (e.g., follow an engineered cap placement sequencing strategy, follow appropriate material placement methods to achieve uniform coverage). See Section 2.4.5 for additional details and impact minimization measures. • Employ operational BMPs (e.g., work from lower to higher elevations during placement) to minimize sediment disturbance and dispersion. See Section 2.4.5 for additional details. • Perform monitoring of water quality standard parameters (turbidity, DO, temperature, and pH) in accordance with EPA-approved water quality monitoring plan during in-water work. • Imported materials must be approved before use; therefore, testing of the borrow source material will be required of the contractor to demonstrate that the source material meets chemical and physical criteria. • Place cap or cover layer as soon as possible after dredging to minimize recontamination risk from contaminants. • Imported materials should consist of clean, granular material free of roots, organic material, contaminants, and all other deleterious material. • Adhere to emergency spill response measures according to contractor's spill containment and control plan. • Dredging will occur prior to prospective engineered capping or backfill placement in areas with an existing elevation of -10 feet MLLW or shallower to allow for net zero bathymetry change. • Place a sand and gravel habitat layer (e.g., fish/habitat mix) on top of the cap armor layer and as backfill in areas at elevation -10 feet MLLW or shallower, unless existing condition is a steep armored slope, to enhance substrate for benthic invertebrates, which are prey for juvenile salmonids. The habitat material will also fill in the interstitial spaces between the cap armor, which will remove potential hiding places for salmonid predators. • Place RMC (sand layer) within the dredge prism to manage dredge residuals.

Action Component ¹	Where	When	Avoidance and Minimization Measures
Placement of RMC in the inner and outer dredge perimeter, ENR, and amended cover materials (no dredging, only material placement; includes a contingency to account for the potential that the RAA boundaries may be revised based on new Phase III PDI data)	RMC (no dredging; placement of 6- to 12-inch sand layer in the inner and outer dredge perimeter): LDW, up to 12.1 acres. ENR (no dredging; placement of 6- to 12-inch sand and gravel layer): LDW over up to 0.83 acre. Amended cover (no dredging; 6- to 12-inch sand and gravel layer amended with granulated activated carbon): LDW in portions of RAAs 18, 24, and 26 over up to 0.18 acre.	In-water work window across three construction seasons; for each RAA, construction will only occur during one season.	<ul style="list-style-type: none"> • Conduct all in-water work within the approved in-water work window when juvenile Chinook salmon, steelhead, and bull trout are not expected to be present or are expected only in low numbers. • Implement general impact minimization measures that allow import materials to be placed in a controlled and accurate manner and that limit disturbance of the bottom sediments (e.g., follow appropriate material placement methods to achieve uniform coverage). See Section 2.4.5 for additional details and impact minimization measures. • Employ operational measures (e.g., work from lower to higher elevations during placement) to minimize sediment disturbance and dispersion. See Section 2.4.5 for additional details. • Perform monitoring of water quality standard parameters (turbidity, DO, temperature, and pH) in accordance with EPA-approved water quality monitoring plan during in-water work. • Imported materials should consist of clean, granular material free of roots, organic material, contaminants, and all other deleterious material. • Imported materials must be approved before use; therefore, testing of the borrow source material will be required of the contractor to demonstrate that the source material meets chemical and physical criteria. • Adhere to emergency spill response measures according to contractor's spill containment and control plan. • Place RMC (sand layer) adjacent to the dredge prism to manage dredge residuals. • Place ENR and amended cover (sand and gravel) on top of the existing substrate to accelerate natural recovery processes and to reduce the bioavailability of COCs in biologically active zone, respectively.
In-water structure modifications: pile removal and installation and outfall bank protection	Pile removal and installation: LDW, RAA 13 (remove two timber and three steel pipe piles, install five steel pipe piles), ³ RAA 27 (remove eight timber piles/install one steel pipe pile), RAA 30/31 (remove nine timber piles), LDW in deep subtidal areas outside of the FNC (install up to ten 36-inch steel pipe piles temporarily for contractor's vessel moorage). Outfall bank protection: LDW bank, RAAs 13, 18, 26, 33/34/35 total area of 2,160 square feet (540 square feet each).	In-water work window; for each RAA, construction will only occur during one season.	<ul style="list-style-type: none"> • Conduct all in-water work within the approved in-water work window when juvenile Chinook salmon, steelhead, and bull trout are not expected to be present or are expected only in low numbers. • Employ physical barriers (e.g., floating containment boom), mechanical controls (e.g., vibratory hammer), and operational measures (e.g., slow pile removal, avoid deformation during pile removal) to minimize sediment disturbance and dispersion. See Sections 2.4.6 and 2.4.7 for additional details. • Use a vibratory hammer to minimize noise impacts.

Notes:

1. Transport and transloading of dredged material is not included in this table because potential effects associated with barge transport of contaminated sediment to an on-site or off-site transload facility and transloading material are considered de minimis. Impact avoidance and minimization measures described in Section 2.4.4 of the *Biological Assessment* will further reduce the potential for impacts to occur during these activities.

2. See *Biological Assessment* main text for further description of RAA 27 activity.

3. The pile numbers are conservative, pending changes in design related to Phase III data, which may result in fewer structure changes.

BMP: best management practice

COC: contaminant of concern

DO: dissolved oxygen

ENR: enhanced natural recovery

EPA: U.S. Environmental Protection Agency

FNC: federal navigation channel

LDW: Lower Duwamish Waterway

MLLW: mean lower low water

PDI: pre-design investigation

RAA: remedial action area

RMC: residuals management cover

Attachment E.3

NMFS Underwater Noise Calculator

Acoustics Tool for SERO: Calculate the effects of pile driving noise on ESA-listed species

Last Updated 05/12/21: Corrected calculation of impact effects with noise abatement

DISCLAIMER: This workbook was developed for NMFS Southeast Regional Office (SERO), Protected Resources Division. It is intended to be an in-house tool for assessing the potential effects to ESA-listed species exposed to elevated levels of underwater sound produced during pile driving. The information provided in this spreadsheet uses the best available scientific and commercial information. NMFS assumes no responsibility for interpretation of the results of these models by non-NMFS users.

Sound Measurement Terminology

Measurements of Pressure

Peak sound pressure level: the largest absolute value of the instantaneous sound pressure expressed in decibels referenced to 1 micro Pascal (dB re: 1 μ Pa) in water.

Root Mean Square (RMS): the square root of the average squared pressures over the duration of a pulse; most pile-driving impulses occur over a 50 to 100 millisecond (msec) period, with most of the energy contained in the first 30 to 50 msec (Illingworth and Rodkin, Inc. 2001, 2009). Therefore, RMS pressure levels are generally “produced” within seconds of the operations, and represent the effective pressure and the intensity (in dB re: 1 μ Pa) produced by a sound source.

Measurements of Energy

Sound exposure level (SEL): the integral of the squared sound pressure over the duration of the pulse (e.g., a full pile driving strike). SEL is the integration over time of the square of the acoustic pressure in the signal and is thus an indication of the total acoustic energy received by an organism from a particular source (such as pile strikes). Measured in dB re 1 μ Pa²s.

Single Strike SEL (sSEL): the amount of energy in one strike of a pile.

Cumulative SEL (cSEL): the energy accumulated over multiple strikes or continuous vibration over a period of time; the cSEL value is not a measure of the instantaneous or maximum noise level, but is a measure of the accumulated energy over a period of time to which an animal is exposed.

Behavioral and Physiological (Injury) Thresholds for ESA-Listed Species in NMFS' Southeast Region		
Species & Effect	Threshold	Measurement
Fish Single Strike Injury	206	dBpeak
Fish > 2 g Cumulative Exposure Injury (multiple impulses/impacts)	187	cSEL
Fish \leq 2 g Cumulative Exposure Injury (multiple impulses/impacts)	183	cSEL
Fish \geq 102 g (~0.25 lbs) Cumulative Exposure Injury (vibratory/non-impulsive)	234	cSEL
Fish < 102 g (~0.25 lbs) Cumulative Exposure Injury (vibratory/non-impulsive)	191	cSEL
Fish Behavioral Change	150	dB re 1 μ Pa RMS
Sea Turtle Single Strike Injury	206	dBpeak
Sea Turtle Cumulative Exposure Injury (multiple impulses/impacts)	187	cSEL
Sea Turtle Cumulative Exposure Injury (vibratory/non-impulsive)	234	cSEL
Sea Turtle Behavioral Change	160	dB re 1 μ Pa RMS
Cetacean Physiological*		
Cetacean Behavioral (impulsive)**	160	dB re 1 μ Pa RMS
Cetacean Behavioral (non-pulse)**	120	dB re 1 μ Pa RMS

*Please refer to NOAA's 2016 Marine Mammal Acoustic Technical Guidance document and user spreadsheet for assessing whether or not a project creates underwater noise that exceeds the permanent threshold shift (PTS) or temporary threshold shift (TTS) limits for listed cetaceans: <http://www.nmfs.noaa.gov/pr/acoustics/guidelines.htm>

**Use the impulsive threshold for impact pile driving; use the non-pulse threshold for vibratory pile driving

Practical Spreading Loss Model

This spreadsheet calculates the Practical Spreading Loss Model (PSLM). The equations for PSLM, as well as the assumptions below, were adapted from NMFS Pile Driving Calculations tool created by NMFS West Coast Region:

<http://www.dot.ca.gov/hq/env/bio/files/NMFS%20Pile%20Driving%20Calculations.xls>

Assumptions

- 1) Estimates of underwater sound are based on measured levels from similar size and type of pile. Please refer to Caltrans' compendium (Caltrans 2009; 2012; 2015).
- 2) Fish are assumed to remain stationary and the single strike SEL does not vary in magnitude between strikes.
Cumulative SEL = single-strike SEL + 10*log(# strikes).
- 3) Fish are considered more sensitive to physical injury than sea turtles; therefore, fish thresholds are used as conservative interim criteria.
- 4) Currently there are no data to support a tissue recovery allowance between pile strikes. Therefore, all strikes in any given day are counted, regardless of time between strikes. However, generally the accumulated SEL can be reset to zero overnight (or after a 12 hour period), especially in a river or tidally-influenced waterway when the fish should be moving.
- 5) Effective Quiet. When the received SEL from an individual pile strike is below a certain level, then the accumulated energy from multiple strikes would not contribute to injury, regardless of how many pile strikes occur. This SEL is referred to as “effective quiet”, and is assumed, for the purposes of this spreadsheet, to be 150 dB re 1µPa sSEL. Effective quiet establishes a limit on the maximum distance from the pile where injury to fishes is expected – the distance at which the single-strike SEL attenuates to 150 dB. Beyond this distance, no physical injury is expected, regardless of the number of pile strikes. However, the severity of the injury can increase within this zone as the number of strikes increases.
- 6) Practical Spreading Loss model: (TL = transmission loss constant*log(R₁/R₀))

Spherical (20 logR) and Cylindrical (10 and 15 logR) Spreading Loss				
<i>Instructions: Input range from source to obtain spherical and cylindrical spreading loss (-dB)</i>				
Range (m)	log (R)	20 logR Spherical Spreading Loss (- dB)	10 log R Cylindrical Spreading Loss (- dB)	15 log R Cylindrical Spreading Loss (- dB)
1	0	0	0	0
2	0.301029996	6.020599913	3.010299957	4.515449935
4	0.602059991	12.04119983	6.020599913	9.03089987
8	0.903089987	18.06179974	9.03089987	13.5463498
10	1	20	10	15
25	1.397940009	27.95880017	13.97940009	20.96910013
50	1.698970004	33.97940009	16.98970004	25.48455007
100	2	40	20	30
1000	3	60	30	45
5624	3.750045312	75.00090624	37.50045312	56.25067968
10000	4	80	40	60
31623	4.50003068	90.00006136	45.00003068	67.50004602
500000	5.698970004	113.9794001	56.98970004	85.48455007
1000000	6	120	60	90

Title	Lower Duwamish Waterway Upper Reach Remedial Design
Description	One 36-inch steel pile to be installed and removed as needed with vibratory hammer to support temporary vessel moorage during construction.
Assumptions	Approximately 30 minutes per pile based on projects in similar substrate conditions.

Instructions:

Input: Fill in the green colored cells

B1: Enter a descriptive title for the analysis.
 B2: Enter complete information about the pile driving operation, including the type of pile, size of pile, pile driver type, noise attenuation, hours of operation, etc.
 B3: Enter any assumptions you need to make about the choice of parameter values, project methods, environment, etc.
 B26: Enter the number of seconds of vibration to drive a single pile to final depth (from the Action Agency's description)
 B27: Enter the maximum number of piles to be installed in a single day (from the Action Agency's description of the project)
For the next 6 values, use the information on the Pile Driving Noise Data tab if possible, otherwise contact the Action Agency or search the internet for another source.

B32: Enter the estimated single strike peak pressure (dB re: 1µPa)
 B33: Enter the distance (m) from the pile where B7 was measured
 C32: Enter the estimated single strike SEL (dB re: 1µPa²s). If no direct measurement is available, use peak pressure minus 25 dB
 C33: Enter the distance (m) from the pile where C9 was measured
 D32: Enter the estimated single strike RMS pressure (dB re: 1µPa). If no direct measurement is available, use peak pressure minus 15 dB
 D33: Enter the distance (m) from the pile where D9 was measured
 B38: Enter the transmission loss constant (attenuation with distance), which depends on the model used:
 For deep water (depth is greater than the cSEL radius of effect) use the spherical model attenuation constant = 20
 For shallow water use a cylindrical model attenuation constant = 10 to 15; use 15 if unknown.
 If you use an attenuation constant that was reported with the noise data, be sure that the depth profile and bottom type of your project is similar to the project that generated the data.

Output: Read the values in the blue cells in the Calculated Distances Table

Pile Driving Parameters	
Number of seconds of vibration per pile	1800
Number of piles per day	1
Estimated number of seconds per day	1800

Acoustic Measurements			
Measurement	Peak	SEL	RMS
Measured peak levels at the indicated distance	185	175	175
Measurement distance from source (m)	10	10	10
Calculated levels at the source	200	190	190

← The pre-filled values are the most common--be

Model Assumptions	
Effective Quiet	150
Transmission loss constant (15 if unknown)	15
Cumulative SEL at measured distance	208

Calculated Distances					
	Onset of Physical Injury			Fish Behavior	Sea Turtle Behavior
	Peak	Cumulative SEL dB**		RMS	RMS
	Sea Turtles & Fish	Sea Turtles & Fish ≥ 102 g	Fish < 102 g	dB	dB
Threshold value	206	234	191	150	160
Distance to threshold (meters)	0	0.17252353	126.9155989	464.1588834	100
Distance to threshold (US Standard)	0.0 ft	0.566 ft	416.39 ft	1522.831 ft	328.084 ft

** This calculation assumes that single strike SELs < 150 dB do not accumulate to cause injury (Effective Quiet)

Notes (source for estimates, etc.)

Injury thresholds for fish with swim bladders:

Hastings, M.C. 2010. Recommendations for Interim Criteria for Vibratory Pile Driving. Report for Task Order on Vibratory Pile Driving for Caltrans Contract 43A0228. ICF Jones & Stokes.

Fish with swim bladders are considered more sensitive to physical injury than fish without swim bladders or sea turtles; therefore, thresholds for fish with swim bladders are used as conservative interim criteria.

Fish behavioral threshold:

McCauley, R.D., and coauthors. 2000b. Marine Seismic Surveys: Analysis And Propagation of Air-Gun Signals; And Effects of Air-Gun Exposure on Humpback Whales, Sea Turtles, Fishes and Squid Curtin. University of Technology, Western Australia.

Sea turtle behavioral threshold:

Skalski, J.R., W.H. Pearson, and C.I. Malme. 1992. "Effects of Sounds from a Geophysical Survey Device on Catch-per-Unit-Effort in a Hook-and-Line Fishery for Rockfish (Sebastes spp.)." Canadian Journal of Fisheries and Aquatic Sciences 49:1357–1365.

Title	Lower Duwamish Waterway Upper Reach Remedial Design
Description	Five 14-inch steel pipe piles will be installed to replace three 14-inch steel pipe piles and two 10-inch timber piles that support floats at the South Park Marina.
Assumptions	Approximately 10 minutes per pile based on projects in similar substrate conditions.

Instructions:

Input: Fill in the green colored cells

B1: Enter a descriptive title for the analysis.
 B2: Enter complete information about the pile driving operation, including the type of pile, size of pile, pile driver type, noise attenuation, hours of operation, etc.
 B3: Enter any assumptions you need to make about the choice of parameter values, project methods, environment, etc.
 B26: Enter the number of seconds of vibration to drive a single pile to final depth (from the Action Agency's description)
 B27: Enter the maximum number of piles to be installed in a single day (from the Action Agency's description of the project)

For the next 6 values, use the information on the Pile Driving Noise Data tab if possible, otherwise contact the Action Agency or search the internet for another source.

B32: Enter the estimated single strike peak pressure (dB re: 1µPa)
 B33: Enter the distance (m) from the pile where B7 was measured
 C32: Enter the estimated single strike SEL (dB re: 1µPa²s). If no direct measurement is available, use peak pressure minus 25 dB
 C33: Enter the distance (m) from the pile where C9 was measured
 D32: Enter the estimated single strike RMS pressure (dB re: 1µPa). If no direct measurement is available, use peak pressure minus 15 dB
 D33: Enter the distance (m) from the pile where D9 was measured
 B38: Enter the transmission loss constant (attenuation with distance), which depends on the model used:
 For deep water (depth is greater than the cSEL radius of effect) use the spherical model attenuation constant = 20
 For shallow water use a cylindrical model attenuation constant = 10 to 15; use 15 if unknown.
 If you use an attenuation constant that was reported with the noise data, be sure that the depth profile and bottom type of your project is similar to the project that generated the data.

Output: Read the values in the blue cells in the Calculated Distances Table

Pile Driving Parameters	
Number of seconds of vibration per pile	600
Number of piles per day	1
Estimated number of seconds per day	600

Acoustic Measurements			
Measurement	Peak	SEL	RMS
Measured peak levels at the indicated distance	171	155	155
Measurement distance from source (m)	10	10	10
Calculated levels at the source	186	170	170

← The pre-filled values are the most common--be

Model Assumptions	
Effective Quiet	150
Transmission loss constant (15 if unknown)	15
Cumulative SEL at measured distance	183

Calculated Distances					
	Onset of Physical Injury			Fish Behavior	Sea Turtle Behavior
	Peak	Cumulative SEL dB**		RMS	RMS
	Sea Turtles & Fish	Sea Turtles & Fish ≥ 102 g	Fish < 102 g	dB	dB
Threshold value	206	234	191	150	160
Distance to threshold (meters)	0	0.003849765	2.832049459	21.5443469	4.641588834
Distance to threshold (US Standard)	0.0 ft	0.013 ft	9.292 ft	70.684 ft	15.228 ft
** This calculation assumes that single strike SELs < 150 dB do not accumulate to cause injury (Effective Quiet)					

Notes (source for estimates, etc.)

Injury thresholds for fish with swim bladders:

Hastings, M.C. 2010. Recommendations for Interim Criteria for Vibratory Pile Driving. Report for Task Order on Vibratory Pile Driving for Caltrans Contract 43A0228. ICF Jones & Stokes.

Fish with swim bladders are considered more sensitive to physical injury than fish without swim bladders or sea turtles; therefore, thresholds for fish with swim bladders are used as conservative interim criteria.

Fish behavioral threshold:

McCauley, R.D., and coauthors. 2000b. Marine Seismic Surveys: Analysis And Propagation of Air-Gun Signals; And Effects of Air-Gun Exposure on Humpback Whales, Sea Turtles, Fishes and Squid Curtin. University of Technology, Western Australia.

Sea turtle behavioral threshold:

Skalski, J.R., W.H. Pearson, and C.I. Malme. 1992. "Effects of Sounds from a Geophysical Survey Device on Catch-per-Unit-Effort in a Hook-and-Line Fishery for Rockfish (Sebastes spp.)." Canadian Journal of Fisheries and Aquatic Sciences 49:1357–1365.

Attachment E.4
Water Quality Effects Evaluation,
Appendix K of the Intermediate (60%)
Remedial Design Basis of Design Report

Appendix K

Water Quality Effects Evaluation

TABLE OF CONTENTS

1	Introduction	1
1.1	Background.....	1
1.2	Water Quality Criteria.....	1
1.3	Objectives of Effects Evaluation.....	2
2	Contaminant Input Parameters.....	4
3	Potential Water Quality Effects During Dredging	7
3.1	Predicted Water Quality Effects Using the DREDGE Model.....	7
3.1.1	Model Description.....	7
3.1.2	Model Input Parameters.....	7
3.1.3	Model Results	8
3.2	Turbidity Criteria and Total Suspended Solids Threshold Concentrations.....	9
3.2.1	Turbidity and Total Suspended Solids.....	9
3.2.2	Chemical Concentrations and Total Suspended Solids.....	10
4	Potential Effects During Barge Dewatering and Dredge Return Water Discharge .	11
4.1	Model Description	11
4.2	Model Input Parameters.....	12
4.3	Model Results	12
5	Summary and Conclusions	13
6	References	14

TABLES

Table K-1	Water Quality Criteria and Parameters from the CLARC Database
Table K-2	Summary Chemical Concentrations for Water Quality Evaluations
Table K-3	DREDGE Model Input Parameters
Table K-4	DREDGE Model Output for Acute Water Quality Criteria
Table K-5	DREDGE Model Output for Chronic Water Quality Criteria
Table K-6	Average TSS Threshold Concentrations that Exceed Water Quality Criteria
Table K-7	Barge Dredge Return Water Model Input Parameters
Table K-8	Barge Dredge Return Water Area of Mixing Calculation

FIGURE
Figure K-1

Calculation of Vertically Weighted Average Concentration.....5

ABBREVIATIONS

CLARC	Cleanup Levels and Risk Calculation
COC	contaminant of concern
CWA	Clean Water Act
cy/day	cubic yard per day
cy/hour	cubic yard per hour
EPA	U.S. Environmental Protection Agency
LDW	Lower Duwamish Waterway
mg/L	milligram per liter
NTU	nephelometric turbidity unit
PCB	polychlorinated biphenyl
RAL	remedial action level
RD	remedial design
TSS	total suspended solids
USACE	U.S. Army Corps of Engineers
WAC	Washington Administrative Code

1 Introduction

1.1 Background

Dredging of contaminated sediment inherently results in temporary water quality effects during construction. Therefore, significant effort has been made to understand and limit water quality effects during remediation (e.g., *The Four Rs of Environmental Dredging: Resuspension, Release, Residual, and Risk* [USACE 2008]). Moreover, there is an established set of tools commonly used to analyze potential water quality effects during dredging operations and typical approaches employed for managing those potential effects.

Remedial activities in the Lower Duwamish Waterway (LDW) upper reach are anticipated to consist of mechanical dredging of contaminated sediment, which will be placed into and dewatered on a haul barge. Barge dewatering generates dredge return water (i.e., dredging return water that is made up of free water captured by the dredging bucket and placed into the barge or porewater generated from dewatering of the sediment stockpile on the barge). This dredge return water typically is discharged back to the receiving waters within the dredging work zone after suspended solids are filtered out of the dredge return water.

This appendix provides a screening-level evaluation of predicted water quality effects during both remedial dredging and barge dewatering to help inform the development of water management requirements in the specifications and a Water Quality Monitoring Plan as part of the Construction Quality Assurance Plan during Pre-Final (90%) Remedial Design (RD). The results of this appendix can be considered by the U.S. Environmental Protection Agency (EPA) to inform the detailed water quality monitoring requirements in EPA's Clean Water Act (CWA) Section 404 ARAR Memorandum.

1.2 Water Quality Criteria

The LDW upper reach RD is required to substantively comply with applicable federal and Washington State water quality criteria, as noted in the Intermediate (60%) RD *Basis of Design Report* Section 3.2.

EPA will determine specific compliance criteria, measurement methods, mixing zones, and other conditions in the CWA Section 404 ARAR Memorandum. The *Record of Decision* (EPA 2014) states that the LDW is considered marine water under the state's water quality standards regulation because it meets the salinity threshold described in Washington Administrative Code (WAC) 173-201A-260(3)(e) and that salinity measurements show tidal conditions exist beyond the turning basin. The *Record of Decision* also states that the LDW is not specifically noted in WAC 173-201A-610 and 612, Table 612, but is a continuation of Elliott Bay for the purposes of applying marine criteria. Based on the beneficial use classification of the LDW as "excellent quality" to support salmonid migration and rearing, the compliance criteria for conventional parameters will likely be the

“excellent quality” Washington State Surface Water Quality Standards for marine waters (WAC 173-201A-210). The Water Quality Monitoring Plan will develop specific monitoring methods to be used during construction, in alignment with that certification.

For the purposes of this appendix, turbidity water quality standards for the project are based on WAC 173-201A-210(1)(e) for waters designated as “excellent” marine quality. The turbidity criterion is to not exceed 5 nephelometric turbidity units (NTU) above background (or 10% above background if background is 50 NTU or higher) at the edge of the designated area of mixing during construction activities. For estuarine waters in Washington State, the standard point of compliance for a temporary area of mixing is identified as 150 feet from the activity causing the disturbance. However, sediment remediation projects often request an area of mixing larger than the point of compliance, in part because it is not safe or sometimes physically possible to sample that close to the working equipment. The proposed area of mixing is described in the Water Quality Monitoring Plan detailed outline (Attachment F-1 to Appendix F) and based on a variety of considerations. For this analysis, the water quality effects evaluation calculated all predicted concentrations and comparisons to water quality criteria using a value of 150 feet.

Acute and chronic criteria for protection of aquatic life in marine water were selected as the water quality standards for contaminants in sediment that could enter the water column due to sediment suspension during dredging or dredging return water from a barge. Applicable water quality criteria are provided in Table K-1 as obtained from Ecology’s Cleanup Levels and Risk Calculation (CLARC)¹ database based on the minimum federal standards (40 Code of Federal Regulations 131.45) and state standards (173-201A WAC) for protection of aquatic life in marine water. Per WAC 173-201A-240, marine water quality criteria are expressed as the dissolved fraction for metals except mercury, which is expressed as total recoverable fraction for the chronic criteria, and polychlorinated biphenyls (PCBs) which are expressed as the total recoverable fraction for both acute and chronic criteria. Criteria are averaged over a specific time frame (i.e., a 1-hour average for the acute criterion, a 4-day average for the chronic criterion, and a 24-hour average for total PCBs for both acute and chronic).

1.3 Objectives of Effects Evaluation

The objectives of this water quality effects evaluation are as follows:

1. Estimate the predicted total and dissolved contaminant of concern (COC) concentrations that may be mobilized into the water column during dredging at the edge of the area of mixing during construction (Section 3).

¹ The CLARC is a database maintained by Ecology that compiles both Washington State and federal cleanup levels for media and contaminants.

2. Estimate the predicted total and dissolved COC concentrations that may be discharged to waters within the construction work zone during barge dewatering and transported to the edge of the area of mixing (Section 4).

Section 2 summarizes the contaminant input parameters used in both analyses.

2 Contaminant Input Parameters

The chemical concentrations in dredged sediment are a key input to the water quality evaluation. Two different contaminant concentrations in sediment were evaluated for each modeled contaminant. A high concentration was calculated to represent a maximum concentration that may be dredged for comparison to acute water quality criteria. An area-wide representative concentration was calculated to represent an average concentration that will be dredged for comparison to chronic water quality criteria (Table K-2). These concentration calculations are discussed in this section.

Core samples in the *Pre-Design Investigation Data Evaluation Report* (Anchor QEA and Windward 2022) design dataset were used to estimate contaminant concentrations in dredged sediment. Because dredging inherently mixes sediment, the vertically weighted average concentration in each core (excluding cores without contamination) was calculated. This approach results in a conservatively high average concentration. The dredge depth of each core was estimated based on the maximum depth of contamination for each core, plus 1 foot of overdredging (i.e., if depth of contamination is 4 feet, the total dredge depth is 5 feet). Then the vertically weighted average concentration was calculated for each core by calculating the sum of each core interval's chemical concentration multiplied by the length of that core interval for every analyzed core interval, divided by the total length of all analyzed core intervals for each individual core (Figure K-1).

Figure K-1
Calculation of Vertically Weighted Average Concentration

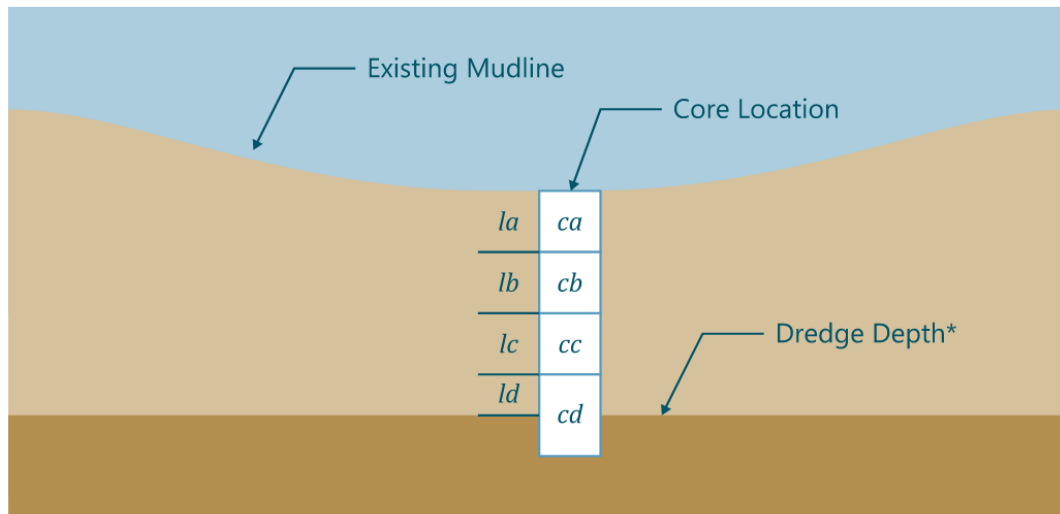

$$C_{avg} = \frac{(la)(ca) + (lb)(cb) + (lc)(cc) + (ld)(cd)}{la + lb + lc + ld}$$

Where:

- c_x = concentration in core interval "x"
- l_x = length of core interval "x" included in vertically weighted average
- C_{avg} = vertically weighted average

Note*: Dredge depth was estimated based on the maximum depth of contamination for each core, plus 1-ft of overdredge

After the vertically weighted average concentration for every core within remedial action level (RAL) exceedance areas was determined, a maximum and an average concentration were calculated to be used to compare against acute and chronic water quality criteria. The maximum concentration was the highest individual core result (i.e., highest vertically weighted average concentration of all RAL exceedance area cores), and this maximum concentration was compared against acute criteria. The average concentration represents the averaging of all RAL exceedance area cores and was compared against chronic criteria.

The partitioning coefficients for modeled contaminants are also a key input for the water quality effects evaluation. Partitioning coefficients can vary widely depending on geochemical conditions and contaminant characteristics (e.g., mixture of PCBs). For simplicity, the partitioning coefficients were pulled from the values in the CLARC database (Table K-1). The PCBs partitioning coefficient was

calculated based on the organic-carbon-based partitioning coefficient times average percent of organic carbon in the cores.

3 Potential Water Quality Effects During Dredging

3.1 Predicted Water Quality Effects Using the DREDGE Model

3.1.1 Model Description

The U.S. Army Corps of Engineers (USACE) developed the DREDGE Model (Hayes and Je 2000) to help predict contaminant concentrations within the water column that result from dredging operations. The model steps are as follows:

1. The model first estimates the mass rate at which sediments become suspended into the water column during mechanical dredging operations, based on the dredging production rate and the percent loss of material during dredging, which are supplied by the user.
2. Next, the model estimates the transport of the total suspended solids (TSS) plume from the dredging area due to lateral diffusion, transport by ambient water currents, and settlement of suspended solids. This calculation predicts the TSS concentration with distance from the dredging area.
3. Finally, the model estimates the total and dissolved contaminant concentrations in the water column based on contaminant concentrations in the predicted TSS and equilibrium partitioning theory. The model conservatively assumes that partitioning is instantaneous in the water column and that solids-phase concentrations and dissolved-phase concentrations are in equilibrium.

An additional evaluation check was performed using just the third step in the DREDGE Model, to back-calculate the TSS concentration that would be predicted to result in a water quality exceedance based on partitioning assumptions.

3.1.2 Model Input Parameters

Table K-3 presents the model input parameters selected for the evaluations and the rationale for each parameter. The DREDGE Model inputs consist of dredge characteristics and transport parameters. The general approach was to use reasonable conservative assumptions (i.e., assumptions that result in higher concentrations) to account for uncertainty.

The dredging production rate was assumed to be 180 cubic yards per hour (cy/hour) for the acute (1-hour average) evaluation, 1,000 cubic yards per day (cy/day) for the chronic (4-day average), and 1,000 cy/day for the total PCBs acute and chronic (24-hour average) evaluation. Dredging is not a continuous operation because the contractor will not work 24 hours a day (e.g., a typical 10-hour workday involves 6 to 8 hours of active dredging), and there is significant downtime in a typical workday for moving and setting up the dredge plant and equipment maintenance. These are

considered reasonable maximum average production rates for calculating the average conditions over the time frames of interest.

Three percent of the dredged material volume was assumed to be suspended into the water column during dredging, which is high compared to previous studies (e.g., Anchor QEA 2003). The DREDGE Model assumes that suspended solids loading is evenly distributed throughout the water column during the raising of the dredge bucket.

Suspended solids transport lateral diffusion coefficients were established based on discussions with USACE (Schroeder 2019; Table K-3). The site-specific settling rates in the model were determined based on sediment grain sizes and densities. The mean settling velocity is a conservative representation of the TSS (i.e., fine fraction) and was therefore estimated based on the Stokes' law settling velocity of a particle size of 37 micrometers, representative of the median of the fine fraction of dredged material.

The ambient river flow and tidal velocities within LDW vary; however, a speed of 1 foot per second was used for modeling and is considered representative of moderate flow in the LDW. Dredging was not assumed to occur during high-flow storm events because dredging contractors may not be able to safely operate during high-flow events.

3.1.3 Model Results

Table K-4 presents the model results for the acute water quality evaluation (1-hour average; 180 cy/hour). The DREDGE Model predicted a TSS concentration of 15.6 mg/L at 150 feet from the work zone. The resulting predicted total and dissolved concentrations for COCs did not exceed acute water quality criteria.

Table K-5 presents the model results for the chronic water quality criteria (4-day average; 1,000 cy/day). The DREDGE Model predicted an effective average TSS concentration of 3.6 milligrams per liter (mg/L) at 150 feet from the work zone. This is the predicted average TSS concentration averaged over a 4-day period; TSS concentrations at 150 feet would be higher during active dredging. All predicted dissolved COC concentrations were below marine chronic water quality criteria.

In summary, based on site-specific model inputs to the DREDGE Model, no acute or chronic water quality exceedances are predicted for COCs at the point of compliance of 150 feet from the dredging activity.

3.2 Turbidity Criteria and Total Suspended Solids Threshold Concentrations

The preceding section showed that water quality criteria exceedances are not predicted at the point of compliance during dredging operations, based on dredging operational characteristics and modeled hydrodynamic conditions. This section summarizes an additional evaluation performed to illustrate how turbidity monitoring is considered to be appropriate to monitor and identify potential water quality criteria exceedances in real time during dredging. The following subsection (3.2.1) discusses the relationship between turbidity and TSS, which is important for linking the real-time turbidity monitoring with potential water quality effects; however, while turbidity provides important real-time information on water quality, a confirmed turbidity exceedance may trigger a request from EPA for chemical analysis for relevant COCs to determine if an exceedance of water quality criteria has occurred. The next subsection (3.2.2) discusses a back-calculation method to predict concentrations of TSS that would need to be observed at the point of compliance from dredging operations that potentially could result in acute or chronic water quality criteria exceedances. Together, these evaluations demonstrate that real-time turbidity measurements are considered to be an appropriate method to monitor for potential water quality exceedances due to dredging operations.

3.2.1 Turbidity and Total Suspended Solids

Turbidity is a water quality parameter that refers to how clear the water is. TSS are physical particles in the water (e.g., sediment), and turbidity is the effect on light caused by those particles and anything else that affects light. Therefore, there is not a constant relationship between turbidity and TSS, but they are related. The greater the amount of TSS in the water, the murkier it appears and the higher the measured turbidity. However, turbidity is also caused by discoloration of the water affecting light transmission through the water; therefore, the relationship between turbidity and TSS can fluctuate at any site. Because turbidity is generally correlated with TSS and provides real-time feedback about water quality during dredging operations, it is commonly used as the primary tool to assess whether significant resuspension is occurring during dredging operations.

Turbidity is commonly used to assess water quality effects during dredging, with a criterion established relative to ambient background concentrations to assess the contributory effect of dredging on turbidity (e.g., 5 NTU above background, or 10% above background when background turbidity > 50 NTU). Turbidity measurements provide real-time information about the potential effects to water quality due to dredging and therefore can provide near real-time feedback to the contractor. Although TSS is used in predictive modeling, real-time measurements of TSS during dredging are not possible (i.e., TSS requires laboratory analysis). As such, turbidity, which has a relationship to TSS, is recommended for real-time measurements of water quality during dredging.

Based on literature (Thackston and Palermo 2000; Anchor QEA 2003) and Anchor QEA's, experience at other remedial dredging sites, the turbidity to TSS relationship ranges from approximately 1 NTU = 0.5 mg/L TSS to 1 NTU = 4 mg/L TSS, with 1 NTU = 2 mg/L TSS considered to be a reasonable relationship. Specific turbidity criteria to be recommended for the LDW upper reach will be described in the Water Quality Monitoring Plan during Pre-Final (90%) RD.

3.2.2 Chemical Concentrations and Total Suspended Solids

The partitioning component of the DREDGE Model was used to back-calculate the concentrations of TSS that would result in acute or chronic water quality criteria. Table K-6 presents the TSS concentrations at the 150-foot point of compliance that would exceed acute and chronic water quality criteria based on the maximum and the mean concentrations in cores. The lowest TSS concentration that could result in an acute water criteria exceedance was for copper. The copper acute water quality criterion of 4.8 micrograms per liter was predicted to be exceeded at 21 mg/L TSS above the background TSS at the 150-foot compliance point. Because 1 NTU equates to approximately 0.5 to 4 mg/L TSS, the compliance criterion of 5 NTU above background would be predicted to equate to an approximate TSS concentration of 2.5 to 20 mg/L above background, which is lower than the predicted concentration required to exceed the copper acute criteria. Because all other COCs are predicted to require a much higher TSS concentration than copper to potentially exceed acute criteria at the point of compliance, this evaluation shows there is low risk of exceeding the acute criteria at the point of compliance under any dredging scenarios.

The lowest TSS concentration that exceeded chronic water criteria was for total PCBs. The chronic water quality criterion of 0.030 microgram per liter was predicted to be exceeded at 43 mg/L TSS above the background TSS, indicating that the long-term average TSS concentration should be maintained below 43 mg/L above background. Again, considering a typical turbidity to TSS conversion of 1 NTU = 0.5 to 4 mg/L TSS, the project compliance criterion of 5 NTU above background would be predicted to equate to an approximate TSS concentration of 2.5 to 20 mg/L above background, which is also protective of chronic water quality criteria.

4 Potential Effects During Barge Dewatering and Dredge Return Water Discharge

Dredging return water is typically discharged from the barge to the dredging work zone after filtration to remove suspended solids. The dredge return water is one of the many processes during dredging that contributes to overall effects on the water column. This section provides a screening-level assessment of the incremental contribution of the return water to ambient chemical concentrations in the water column.

4.1 Model Description

The effects of barge dewatering dredge return water were estimated using the procedure in *Evaluation of Dredged Material Proposed for Discharge in Water of the U.S. – Testing Manual, Appendix C* (USACE 1998). The following steps were performed:

- The average concentration in sediment cores and the chronic water criteria were used because sediment mixes in the barge, and barge dredge return water discharge can take place throughout the day (even when dredging is not being performed).
- The dissolved contaminant concentrations in porewater were calculated by partitioning theory.
- Sediment porewater was assumed to mix on the barge with free water captured by the dredging buckets during dredging.
- The barge dredge return water was assumed to discharge continuously into the dredging work zone.
- The dissolved concentration and discharge rate of barge dredge return water were compared to water quality criteria to calculate a required dilution factor to meet water quality criteria. The dilution factor is calculated using the following EFQUAL equation (USACE 1991):

$$\text{dilution factor} = \frac{(\text{concentration in the dredge return water discharge}) - (\text{water quality standard})}{\text{water quality standard}}$$

- The dilution factor is the ratio of surface water to dredge return water that needs to be mixed together to meet the water quality criteria. This dilution factor is used to determine the quantity of water that must be diluted with dredge return water and the distance of mixing to meet the water quality criteria in the next step.
- Finally, a distance of mixing was calculated based on the approach described in *Evaluation of Dredged Material Proposed for Discharge in Water of the U.S. – Testing Manual, Appendix C*

(USACE 1998) that achieves the chronic water quality criteria. This distance was compared to the typical point of compliance of 150 feet for in-water construction activities.

4.2 Model Input Parameters

Table K-7 presents the model input parameters selected for the evaluation and the rationale for each parameter. The model assumptions are similar to the DREDGE Model. The production rate was assumed to be 1,000 cy/day of in situ dredged sediment, consistent with a comparison to chronic criteria (4-day average). The proportion of free water compared to the in situ volume of sediment is 43%, calculated by assuming a bucket fill factor of 70%, and a conservatively high assumption of bucket free water at 30% of the bucket volume placed on the barge (i.e., $30\% / 70\% = 43\%$). This assumption results in a free water volume of 430 cy/day. The volume of free water is then assumed to discharge continuously from the barge (i.e., 430 cy/day = 228 liters per minute). The dissolved concentration in barge dredge return water is calculated based on porewater concentrations for each chemical (based on partitioning). The volume of sediment porewater is assumed to fully mix with the volume of free water, which results in conservatively higher barge dredge return water concentrations.

The turbulent dissipation parameter was assumed to be 0.005 based on the recommendations in *Evaluation of Dredged Material Proposed for Discharge in Water of the U.S. – Testing Manual, Appendix C* (USACE 1998). A depth of mixing was assumed to be 3 meters, which conservatively assumes that mixing does not occur in the entire water column, and the ambient water velocity was assumed to be 1 foot per second.

4.3 Model Results

Table K-8 presents the results of the barge dredge return water discharge evaluation. The largest required mixing zone of 60 feet was calculated to achieve chronic water quality criteria for copper. All other COCs meet chronic criteria closer than 60 feet to the barge discharge. Based on this evaluation, water quality criteria for COCs are predicted to be met at the point of compliance 150 feet from the work zone for barge dredge return water discharge.

5 Summary and Conclusions

Screening-level site-specific water quality modeling predicts there is unlikely to be water quality criteria exceedances for COCs due to suspension of sediment during dredging operations, or from barge dredge return water discharge of dissolved concentrations. Based on this water quality assessment, it is unlikely there will be a chronic exceedance when the barge dredge return water discharge is combined with water quality effects associated with dredging. Monitoring for turbidity at 150 feet or the closest safe distance from dredging and barge discharge is expected to provide real-time feedback of water quality conditions during dredging and provide a mechanism for corrective action(s) should excessive sediment suspension be observed. Further, the turbidity compliance criterion (5 NTU above background, or 10% above background when background turbidity > 50 NTU) is predicted to result in COC concentrations less than marine water quality criteria and supports the use of turbidity as the primary evaluation metric. The proposed water quality criteria, area of mixing (and point of compliance), and procedures for water quality monitoring, reporting, and potential contingency response actions (i.e., procedures to follow in the case of a water quality exceedance) will be described in the Water Quality Monitoring Plan to be developed during Pre-Final (90%) RD.

The results of this appendix can be considered by EPA to inform the detailed water quality monitoring requirements in EPA's CWA Section 404 ARAR Memorandum. Actual water quality monitoring, as defined in the Water Quality Monitoring Plan, will be conducted during remedial actions, and the contractor will be required to modify operations to remain in compliance with the requirements outlined in EPA's CWA Section 404 ARAR Memorandum.

6 References

- Anchor QEA (Anchor QEA, LLC), 2003. Literature Review of Effects of Resuspended Sediments Due to Dredging Operations. Prepared for Los Angeles Contaminated Sediments Task Force Los Angeles, California.
- Anchor QEA and Windward (Windward Environmental), 2022. *Pre-Design Investigation Data Evaluation Report*. Final. Submitted to EPA July 15, 2022.
- Ecology (Washington State Department of Ecology), 2021. CLARC Database July 2021 Update. Available at: <https://ecology.wa.gov/Regulations-Permits/Guidance-technical-assistance/Contamination-clean-up-tools/CLARC/Data-tables>.
- EPA (U.S. Environmental Protection Agency), 2014. *Record of Decision*. Lower Duwamish Waterway Superfund Site. United States Environmental Protection Agency Region 10. November 2014.
- ERDC (U.S. Army Corps of Engineers Engineer Research and Development Center), 2008. *Technical Guidance for Environmental Dredging of Contaminated Sediments*. USACE ERDC/EL TR-08-29. September 2008.
- Hayes, D.F., and C.H. Je, 2000. *DREDGE Model User's Guide*. University of Utah, Department of Civil and Environmental Engineering. July 2000.
- Schroeder, Paul (USACE), 2019. Personal communication with Greg Brunkhorst (Anchor QEA). December 3, 2019.
- Thackston, E. L., and Palermo, M. R. (2000). "Improved methods for correlating turbidity and suspended solids for monitoring," DOER Technical Notes Collection (ERDC TN-DOER-E8), U.S. Army Engineer Research and Development Center, Vicksburg, MS. Available at: www.wes.army.mil/el/dots/doer.
- USACE (U.S. Army Corps of Engineers), 1991. *Environmental Effects of Dredging, Technical Notes Documentation of the EFQUAL Module for ADDAMS: Comparison of Predicted Effluent Water Quality with Standard EEDP-06-13*. November 1991.
- USACE, 1998. *Evaluation of Dredged Material Proposed for Discharge in Water of the U.S. – Testing Manual, Appendix C*.
- USACE, 2008. *The Four Rs of Environmental Dredging: Resuspension, Release, Residual, and Risk*. Technical Report ERDC/EL TR-08-4. Vicksburg, MS: U.S. Army Engineer Research and Development Center. February 2008.

USACE et al. (U.S. Army Corps of Engineers, U.S. Environmental Protection Agency, National Oceanic and Atmospheric Administration Fisheries – West Coast Region, U.S. Fish and Wildlife Service, Oregon Department of Environmental Quality, Idaho Department of Environmental Quality, Washington Department of Natural Resources, Washington Department of Ecology), 2016. *Sediment Evaluation Framework for the Pacific Northwest*. Table 9-2. July 2016.

Tables

Table K-1
Water Quality Criteria and Partitioning Coefficients from the CLARC Database

Chemical	Marine Acute (µg/L)	Marine Chronic (µg/L)	Kd (L/kg)	Koc (L/kg)
Arsenic	69	36	29	
Cadmium	33	7.9	6.7	
Chromium VI	1,100	50	19	
Copper	4.8	3.1	22	
Lead	140	5.6	10,000	
Mercury	1.8	0.025	52	
Nickel	74	8.2	65	
PCBs	10	0.030		78,100
Silver	1.9		8.3	
Zinc	90	81	62	

Notes:

Blank cells = not applicable

1. Values from Ecology's CLARC database.
2. COCs selected based on COCs in the Design Dataset with Water Quality Criteria.
3. Water Quality Criteria are the lowest of Federal (40 CFR 131.45) and Washington State Standards (173-201A WAC) for protection of aquatic life.
4. Acute and chronic criteria for metals (except mercury) are based on the dissolved fraction.
5. The chronic criterion for mercury is based on total recoverable and the acute criterion is based on the dissolved fraction (WAC 173-201A-240).
6. Criteria for total PCBs are based on total recoverable fraction (WAC 173-201A-240).

µg/L: microgram per liter

CFR: Code of Federal Regulations

CLARC: Cleanup Levels and Risk Calculation

COC: contaminant of concern

L/kg: liter per kilogram

PCB: polychlorinated biphenyl

WAC: Washington Administrative Code

Table K-2
Summary Chemical Concentrations for Water Quality Evaluations

Chemical	Unit	Maximum of Cores	Mean of Cores
Arsenic	mg/kg	662	18
Cadmium	mg/kg	6.0	0.61
Chromium	mg/kg	188	29
Copper	mg/kg	228	46
Lead	mg/kg	844	47
Mercury	mg/kg	0.58	0.17
Silver	mg/kg	1.1	0.29
Zinc	mg/kg	1,790	113
PCBs	µg/kg	6,680	738

Notes:

1. Core statistics based on the Design Dataset samples within the dredge prism.
2. Each core concentration is the vertically weighted average concentration of core samples within the dredge prism.
3. The preliminary dredging depth for this analysis is based on the depth of benthic SCO exceedances (e.g., 12 mg/kg OC for Total PCBs) plus 1 foot of overdredging.

µg/microgram per kilogram

mg/kg: milligram per kilogram

OC: organic carbon

PCB: polychlorinated biphenyl

SCO: sediment cleanup objective

Table K-3
DREDGE Model Input Parameters

Parameter	Value	Unit	Rationale
Dredge Characteristics			
Production Rate	180 cy/hour (acute); 1000 cy/day (chronic)	varies	Based on dredging project experience within the LDW. 180 cy/hour represents a maximum 1-hour dredge rate for comparison to acute criteria. 1000 cy/day represents an average 4-day dredge rate for comparison to chronic criteria.
In Situ Dry Density	919	kg/m ³	Calculated based on an average total solids of 59% assuming a particle density of 2.60 (specific gravity).
Source Strength (Percent Loss from Dredge Bucket)	3	percent	1% typical of environmental bucket. 3% is a conservative estimate (higher TSS).
Transport Characteristics			
Lateral Diffusion Coefficient	10,000	cm ² /s	Reasonable based on personal communication with Paul Schroeder, USACE (December 3, 2019) for LDW and laterally bounded waterways.
Settling Velocity	0.00077	m/s	Calculated based on Stokes' Law assuming 37 µm particle size (half of the 74 µm upper threshold of fine-grained material).
Water Depth	5	m	Within the range of LDW water depth during construction.
Ambient Water Velocity	1	ft/s	Flow changes with river stage and tidal conditions. 1 ft/sec was selected as a reasonable minimum average flow velocity over time. Higher flow velocities reduce predicted TSS due to dilution effects.
Particle Size (Diameter)	37	µm	Particle size is used to calculate the settling velocity (median of fines fraction).
Specific Gravity of Sediment Particles	2.6	unitless	The average specific gravity from design dataset samples is 2.6, with a range between 2.3 and 2.66.

Notes:

µm: micrometer

cm²/s: square centimeter per second

cy: cubic yard

ft/s: foot per second

kg/m³: kilogram per cubic meter

LDW: Lower Duwamish Waterway

m: meter

m/s: meter per second

TSS: total suspended solids

USACE: U.S. Army Corps of Engineers

Table K-4
DREDGE Model Output Compared to Marine Acute Water Quality Criteria

Chemical	Marine Acute Criteria (µg/L)	Maximum of Cores (mg/kg)	Concentration at 150 Feet (µg/L)
Arsenic	69	662	10
Cadmium	33	6.0	0.093
Chromium VI	1,100	188	2.9
Copper	4.8	228	3.5
Lead	140	844	11
Mercury	1.8	0.58	0.0090
PCBs	10	6.7	0.0027
Silver	1.9	1.1	0.017
Zinc	90	1,790	28

Notes:

1. DREDGE model predicted an effective average TSS concentration of 15.6 mg/L at the 150-foot point of compliance.
2. TSS value represents the average over a 1-hour period for acute criteria, except for PCBs, for which DREDGE model predicted an effective average TSS concentration of 3.6 mg/L at the 150-foot point of compliance, representing the average over a 24-hour period for both acute and chronic criteria (WAC 173-201A-240).
3. Water Quality Criteria are the lowest of Federal (40 CFR 131.45) and Washington State Standards (173-201A WAC) for protection of aquatic life.
4. Maximum of Cores refers to the maximum vertically-weighted average concentration among cores in the dredge prism.
5. Total chromium concentrations are compared to chromium VI water quality criteria.
6. Criteria for metals are based on the dissolved fraction.
7. Acute criteria for total PCBs are based on total recoverable fraction (WAC 173-201A-240).

µg/L: microgram per liter

CFR: Code of Federal Regulations

mg/kg: milligram per kilogram

mg/L: milligram per liter

PCB: polychlorinated biphenyl

TSS: total suspended solids

WAC: Washington Administrative Code

Table K-5
DREDGE Model Output Compared to Chronic Water Quality Criteria

Chemical	Marine Chronic Criteria (µg/L)	Mean of Cores (mg/kg)	Concentration at 150 Feet (µg/L)
Arsenic	36	18	0.066
Cadmium	7.9	0.61	0.0022
Chromium VI	50	29	0.10
Copper	3.1	46	0.17
Lead	5.6	47	0.16
Mercury	0.025	0.17	0.00062
PCBs	0.030	0.74	0.0027
Silver		0.29	0.0011
Zinc	81	113	0.41

Notes:

Blank cells = not applicable

1. DREDGE model predicted an effective average TSS concentration of 3.6 mg/L at the 150-foot point of compliance.
2. TSS value represents the average over a 4-day period for chronic criteria, except for PCBs, for which the TSS value represents the average over a 24-hour period for both acute and chronic criteria (WAC 173-201A-240).
3. Water Quality Criteria are the lowest of Federal (40 CFR 131.45) and Washington State Standards (173-201A WAC) for protection of aquatic life.
4. Mean of Cores refers to the average of the vertically-weighted average concentration among cores in the dredge prism.
5. Total chromium concentrations are compared to chromium VI water quality criteria.
6. Criteria for metals (except mercury) are based on the dissolved fraction.
7. Chronic criteria for mercury and total PCBs are based on total recoverable fraction (WAC 173-201A-240).

µg/L: microgram per liter

CFR: Code of Federal Regulations

mg/kg: milligram per kilogram

mg/L: milligram per liter

PCB: polychlorinated biphenyl

TSS: total suspended solids

WAC: Washington Administrative Code

Table K-6
Average TSS Threshold Concentrations that Exceed Water Quality Criteria

Chemical	Marine Acute Criteria (µg/L)	Marine Chronic Criteria (µg/L)	Maximum of Cores (mg/kg)	Mean of Cores (mg/kg)	TSS Equivalent to the Marine Acute Criteria Based on the Maximum of Cores (mg/L)	TSS Equivalent to the Marine Chronic Criteria Based on the Mean of Cores (mg/L)
Arsenic	69	36	662	18	105	> 1000
Cadmium	33	7.9	6.0	0.61	> 1000	> 1000
Chromium VI	1,100	50	188	29	> 1000	> 1000
Copper	4.8	3.1	228	46	21	67
Lead	140	5.6	844	47	> 1000	> 1000
Mercury	1.8	0.025	0.58	0.17	> 1000	145
PCBs	10	0.030	6.7	0.74	> 1000	41
Silver	1.9		1.1	0.29	> 1000	
Zinc	90	81	1,790	113	50	756

Notes:

Blank cells = not applicable

1. Contaminant partitioning is used to back-calculate the TSS that results in exceedances of dissolved criteria (except for mercury and PCBs, which are described below). Criteria are applicable at the 150-foot point of compliance.
2. Maximum sediment concentrations are based on the maximum vertically-weighted average core concentrations in cores from the Design Dataset and are coupled with acute criteria.
3. Mean sediment concentrations are based on the mean vertically-weighted average core concentrations in cores from the Design Dataset and are coupled with chronic criteria.
4. Acute criteria for total PCBs are based on total recoverable fraction (WAC 173-201A-240).
5. Chronic criteria for mercury and total PCBs are based on total recoverable fraction (WAC 173-201A-240).

µg/L: microgram per liter

mg/kg: milligram per kilogram

mg/L: milligram per liter

PCB: polychlorinated biphenyl

TSS: total suspended solids

WAC: Washington Administrative Code

Table K-7
Barge Effluent Model Input Parameters

Parameter	Value	Unit	Rationale
Dredge Characteristics			
Production Rate	1000	cy/day	Based on dredging project experience within the LDW. 1000 cy/day represents an average 4-day dredge rate for comparison to chronic criteria.
In Situ Dry Density	919	kg/m ³	Calculated based on an average total solids of 59% assuming a particle density of 2.60 (specific gravity).
Proportion of Free Water to In Situ Volume of Sediment	43%	percent	Assuming a 70% bucket fill factor and the other 30% of the bucket is made up of free water. (30% / 70% = 43%)
Barge Water Effluent Discharge Rate	228	L/min	Equivalent to 430 cy/day free water discharged continuously.
Transport Characteristics			
Assumed Turbulent Dissipation Parameter	0.005	unitless	Recommended in USACE (1998) for estuary system.
Depth of Mixing	3	m	Discharge is assumed to mix to a depth of 3 meters.
Ambient Water Velocity	1	ft/s	Flow changes with river stage and tidal conditions. 1 ft/s was selected as a reasonable minimum average flow velocity over a tidal cycle. Higher flow velocities reduce predicted TSS due to dilution effects.
Specific Gravity of Sediment Particles	2.6	unitless	Reasonable specific gravity for LDW sediments.

Notes:

1. Dissolved chemical concentrations are calculated based on porewater concentrations for each chemical (based on partitioning). The volume of porewater is then assumed to mix with the volume of free water.

cy: cubic yard

ft/s: foot per second

kg/m³: kilogram per cubic meter

LDW: Lower Duwamish Waterway

L/min: liter per minute

m: meter

USACE: U.S. Army Corps of Engineers

Table K-8
Barge Effluent Area of Mixing Calculation

Chemical	Marine Chronic Criteria (µg/L)	Sediment Concentration (mg/kg)	Dissolved Concentration in Effluent (µg/L)	Dilution Factor	Area of Mixing (feet)
Arsenic	36	18	364	9.1	4.7
Cadmium	7.9	0.61	47	4.9	3.1
Chromium VI	50	29	858	16	6.9
Copper	3.1	46	1,201	387	57
Lead	5.6	47	2.8		
Mercury	0.025	0.17	1.9	77	19
PCBs	0.030	0.74	0.36	11	5.3
Silver		0.29	19		
Zinc	81	113	1,074	12	5.7

Notes:

1. Sediment concentrations are based on the mean vertically-weighted average core concentrations in cores from the Design Dataset coupled with chronic criteria.
2. Dissolved chemical concentrations are calculated based on porewater concentrations for each chemical (based on partitioning). The volume of porewater is then assumed to mix with the volume of free water.
3. The dilution factor is the ratio of surface water to dredge return water that needs to be mixed in order to achieve water quality criteria, and is calculated using the EFQUAL equation (USACE 1991).
4. Area of mixing based on the Dilution Volume Method for CDF Effluent Discharges in USACE, 1998. Evaluation of Dredged Material Proposed for Discharge in Water of the U.S. – Testing Manual, Appendix C.
5. The dredge return water discharge rate based on the rate of dredging and the volume of free water is 228 L/min.

µg/L: microgram per liter

L/min: liter per minute

mg/kg: milligram per kilogram

Attachment E.5

Vegetation Observations, Appendix I to the Final Pre-Design Investigation Data Evaluation Report

Appendix I

Vegetation Observations

1 Introduction

A visual inspection of shoreline vegetation along the upper reach of the Lower Duwamish Waterway was conducted by boat on June 20 and July 1, 2021, as part of the Phase II Pre-Design Investigation (PDI). This inspection built on the information collected during the PDI Phase I visual bank inspection but focused on areas where remediation is anticipated to occur. The inspection included the collection of photographs and detailed observations to document shoreline vegetation within the Phase I remedial action level (RAL) exceedance areas along the upper reach. During the planning phase of the program, periods of predicted daytime moderately low tides (i.e., low enough to observe bank conditions while still being accessible by boat) were identified as potential survey dates, and actual inspection dates were selected based on forecasted weather conditions and team availability.

This appendix provides focused information related to vegetation that may be disturbed during remedial action. Methods to collect this information are detailed in the PDI Quality Assurance Project Plan (QAPP) (Windward and Anchor QEA 2020).

1.1 Vegetation Observation and Photos

Abbreviated terms for species of trees, shrubs, and grass/herbaceous communities observed are defined in Tables I-1 and I-2. At each Phase I RAL exceedance area, photographs were taken and observations were recorded to document vegetation types. Typically, observations were made for the top of bank, middle of bank, and toe of bank. Along the east bank near river mile 3.8, four distinct shoreline conditions were observed, so the photographs and observations were split into four different subarea groups: RM 3.8E-a, RM 3.8E-b, RM 3.8W-c, and RM 3.8W-d. Along the east bank near river mile 4.9, four distinct shoreline conditions were observed, so photographs and observations were split into four subarea groups: RM 4.9E-a, RM 4.9E-b, RM 4.9E-c, and RM 4.9E-d. The vegetation types and shorelines are detailed in Table I-3. Representative photographs for each segment are included in Attachment I-1.

**Table I-1
Plant Community Definitions**

Plant Community ^{1,2}	Species ³	Notes
Trees		
T1	ALRU, POBA, PONI, SABA	Dominated by native, typically overbank zone
T2	ALRU, ARME, PONI, POTR	Dominated by native, typically overbank zone
T3	ALRU, ARME, PIMO, POBA, POTR, PSME, THPL	Dominated by native, typically overbank zone
T4	PSME	Landscaping plantings
Shrubs		
S1	BUDA, RUAR	Dominated by non-native species
S2	BUDA, POCU, RUAR	Dominated by non-native species
S3	BUDA, HEHE, RUAR	Dominated by non-native species
S4	BUDA, CYSC, RUAR	Dominated by non-native species
S5	HODI, RONU, SARA	Dominated by native species, mitigation plantings
Grass, Ferns, Herbaceous		
GH1	ACMI, BRRA, CIAR, COAR, EQAR, FERU, HOLA, HYRA, LOCO, PLLA, SOAS, TAOF, TAVU	Dominated by non-native, typically includes a variety of these species
GH2	IRPS, JUEF, PHCO, SCAC	Wetland species, typically at or below OHWM
GH3	IRPS, JUEF, SCAC	Wetland species, typically at or below OHWM
GH4	DECE, PHAR	

Notes:

1. Plant community categories represent typically present and dominant species.
2. Categories are not intended to provide a comprehensive list of all species present.
3. Species codes are defined in Table I-2.

OHWM: ordinary high water mark

Table I-2
Species Codes

Species Name	Common Name	Native/ Non-Native	Code
Trees			
<i>Alnus rubra</i>	Red alder	Native	ALRU
<i>Acer macrophyllum</i>	Big-leaf maple	Native	ACMA
<i>Arbutus menziesii</i>	Madrone	Native	ARME
<i>Betula papyrifera</i>	Paper birch	Native	BEPA
<i>Crataegus douglasii</i>	Douglas' hawthorn	Native	CRDO
<i>Cupressus leylandii</i>	Leyland cypress	Non-native	CULE
<i>Fraxinus latifolia</i>	Oregon ash	Native	FRLA
<i>Malus pumila</i>	Cultivated apple	Non-native	MAPU
<i>Pinus contorta</i>	Shore pine	Native	PICO
<i>Pinus monticola</i>	Western white pine	Native	PIMO
<i>Populus balsamiera</i> <i>syn. trichocarpa</i>	Black cottonwood	Native	POBA
<i>Populus nigra</i>	Lombardy poplar	Native	PONI
<i>Prunus domestica</i>	Domestic plum	Native	PRDO
<i>Pseudotsuga menziesii</i>	Douglas fir	Native	PSME
<i>Quercus rubra</i>	Red oak	Native	QURU
<i>Salix babylonica</i>	Weeping willow	Native	SABA
<i>Salix scouleriana</i>	Scouler willow	Native	SASC
<i>Thuja plicata</i>	Western red cedar	Native	THGPL
Shrubs			
<i>Buddleia davidii</i>	Butterflybush	Non-native	BUDA
<i>Cornus sercia</i>	Red-twigged dogwood	Native	COSI
<i>Cytisus scoparius</i>	Scotch broom	Non-native	CYSC
<i>Hedera helix</i>	English ivy	Non-native	HEHE
<i>Holodiscus discolor</i>	Oceanspray	Native	HODI
<i>Polygonum cuspidatum</i>	Japanese knotweed	Non-native	POCU
<i>Rosa nutkana</i>	Nootka rose	Native	RONU
<i>Rubus armeniacus</i>	Himalayan blackberry	Non-native	RUAR
<i>Prunus laurocerasus</i>	European laurel	Non-native	PRLA
<i>Rubus ursinus</i>	Trailing blackberry	Native	RUUR
<i>Sambucus racemosa</i>	Red elderberry	Native	SARA
Grass, Ferns, Herbaceous			
<i>Achillea millefolium</i>	Yarrow	Native	ACMI
<i>Alisma plantago-aquatica</i>	American water-plantain	Native	ALPL
<i>Brassica rapa</i>	Common mustard	Non-native	BRRA
<i>Bromus tectorum</i>	Cheat grass	Non-native	BRTE
<i>Carex lyngbii</i>	Lyngbi sedge	Native	CALY
<i>Cirsium arvense</i>	Canada thistle	Non-native	CIAR
<i>Convolvulus arvensis</i>	Field bindweed	Non-native	COAR
<i>Deschampsia cespitosa</i>	Tufted hairgrass	Native	DECE
<i>Digitalis purpurea</i>	Foxglove	Non-native	DIPU
<i>Equisetum arvense</i>	Field horsetail	Native	EQAR
<i>Festuca rubra</i>	Red fescue	Non-native	FERU
<i>Holcus lanatus</i>	Velvet grass	Non-native	HOLA
<i>Hypericum perforatum</i>	St. John's-wort	Non-native	HYPE

Species Name	Common Name	Native/ Non-Native	Code
<i>Hypochaeris radicata</i>	Hairy cat's-ear	Non-native	HYRA
<i>Iris pseudoacorus</i>	Yellow-flag iris	Non-native	IRPS
<i>Juncus effusus</i>	Soft rush	Non-native	JUEF
<i>Lactuca serriola</i>	Prickly lettuce	Non-native	LASE
<i>Lapsana communis</i>	Nipplewort	Non-native	LACO
<i>Lepidium latifolium</i>	Perennial pepperweed	Non-native	LELA
<i>Lotus corniculatus</i>	Birds-foot trefoil	Non-native	LOCO
<i>Phalaris arundinacea</i>	Reed canarygrass	Non-native	PHAR
<i>Phragmites communis</i>	Reed	Non-native	PHCO
<i>Plantago lanceolata</i>	Narrow-leaved plantain	Non-native	PLLA
<i>Polystichum munitum</i>	Swordfern	Native	POMU
<i>Potentilla palustris</i>	Marsh cinquefoil	Native	POPA
<i>Pteridium aquilinum</i>	Bracken fern	Native	PTAQ
<i>Ranunculus repens</i>	Creeping buttercup	Non-native	RARE
<i>Rumex crispus</i>	Curly dock	Native	RUCR
<i>Schoenoplectus acutus</i>	Hardstem bulrush	Native	SCAC
<i>Sonchus asper</i>	Prickly lettuce	Non-native	SOAS
<i>Symphotrichum lanceolatum</i>	Panicled aster	Native	SYLA
<i>Tanacetum vulgare</i>	Common tansy	Non-native	TAVU
<i>Taraxacum officinale</i>	Common dandelion	Non-native	TAOF

Notes:

Bolded items are new observations made in 2021.

**Table I-3
Phase II Vegetation Data**

River Mile ¹	Location Along Bank	Substrate/ Structure	Species	%	Notes
3.5W	Top of bank	Chain link fence above ecology block wall	ACMA	5	Sparse vegetation due to ecology block wall and riprap
			HYPE	1	
			RUAR	1	
			LASE	1	
			LACO	1	
	Middle of bank	Ecology block wall	-	-	No vegetation
	Toe of bank	Medium rip rap	LELA	5	Algal mat and barnacles on subtidal riprap. Small woody debris at high tide line
RUOC			1		
SYLA			5		
3.8E-a	Top of Bank	Sheetpile wall	BUDA	75	Vegetation only at top of wall extending east 50 ft to staging area
			RUAR	15	
			POBA	5	
			HYPE	5	
	Middle of bank	Sheetpile wall	-	-	No vegetation
Toe of bank	Sheetpile wall	-	-	No vegetation	

River Mile ¹	Location Along Bank	Substrate/ Structure	Species	%	Notes
3.8E-b	Top of bank	Sheetpile wall	BUDA	5	Sparse vegetation
	Middle of bank	Sheetpile wall	-	-	No vegetation
	Toe of bank	Gravel and fines	-	-	No vegetation
3.8E-c	Top of bank	Eroded wooden bulkhead with layers of fill and soil	BUDA	60	Vertical slope of eroding fill
			RUAR	10	
			RULA	10	
			ARME	5	
	Middle of bank	Eroded fill from top of bank, 45% of the slope	RUAR	45	Middle of bank held in place by downslope eroded bulkhead
			LELA	5	
			BUDA	5	
			POPA	5	
			FRLA	5	
	Toe of bank	Rock, gravel, and fines	SYLA	5	Aster growing within bulkhead piles
3.8E-d	Top of bank	Sheetpile wall	BUDA	50	Vegetated top of bank is only 5 to 10 ft deep
			RUAR	40	
			BEPA	5	
			POBA	5	
	Middle of bank	Sheetpile wall	-	-	No vegetation
Toe of bank	Rock, gravel, and fines	-	-	No vegetation	
3.9E	Top of bank	Sheetpile wall	BUDA	90	Vegetated top of bank is only 5 to 10 ft deep
			RUAR	10	
	Middle to bank	Sheetpile wall	-	-	No vegetation
	Toe of bank	Rock, gravel, and fines	-	-	No vegetation
4.0E	Top of bank	Medium riprap	RUAR	75	Vegetated top of bank is only 5 to 10 ft deep
			BUDA	24	
	Middle of bank	Medium riprap	RUAR	50	Dense shrubs
			BUDA	40	
			LELA	10	
Toe of bank	Riprap	-	-	Algal mat on riprap	

River Mile ¹	Location Along Bank	Substrate/ Structure	Species	%	Notes
4.1E	Top of bank	Riprap, concrete debris, and fill	BUDA	45	Vegetated layer extends east 20 to 30 ft from top of bank. There is a canopy, shrub, and herb layer.
			FRLA	5	
			POBA	5	
			CULE	5	
			RUAR	10	
			RULA	5	
			HEHE	10	
			HYPE	5	
	PONI	10	Mix of riprap and debris		
	Middle of bank	Riprap, concrete debris, and fill		RUAR	30
				RULA	20
				PONI	5
				FRLA	5
				LELA	5
LASE			5		
Toe of bank	Loose riprap, rock, gravel, sands, and fines	BUDA	30	Substrate is mix of fill and fines (50/50)	
		RUOC	10		
		IRPS	5		
		ALPL	5		
		POPA	5		
4.2E (Slip 6)	Top of bank	Elevated pier	-	-	No vegetation
	Middle of bank	Open	-	-	No vegetation
	Toe of bank	Deepwater	-	-	No vegetation
4.6E	Top of bank	Parking lot bulkhead, riprap, and concrete slabs	BUDA	80	Very dense vegetation
			RUAR	20	
	Middle of bank	Riprap with 40%	BUDA	100	Very dense vegetation
	Toe of bank	Rock, gravel, and fines	-	-	No vegetation
4.7W	Top of bank	Native substrate	ALRU	40	Native substrate and vegetation
			BEPA	20	
			SASC	15	
			HOB1	10	
			PHAR	10	
			COSI	5	
	Middle of bank	Gravel, sand, and silt	TYLA	20	Native substrate and vegetation
			SCVA	20	
			CALY	40	
	Toe of bank	Silt	SCVA	10	Algal mat in depressions, piles in the nearshore
CALY			10		

River Mile ¹	Location Along Bank	Substrate/Structure	Species	%	Notes
4.8W	Top of bank	Native substrate	ALRU	20	Native substrate and vegetation
			BEPA	20	
			SASC	10	
			HODI	5	
			PHAR	40	
	Middle of bank	Gravel, sand, and silt	COSI	5	Native substrate and vegetation
			TYLA	5	
			PHAR	20	
			SCVA	20	
	Toe of bank	Silt	CALY	40	Algal mat in depressions, piles in the nearshore
SCVA			10		
4.9E-a	Top of bank	75% riprap, 25% concrete blocks	PICO	5	Mix of trees and shrubs extending to paved trail
			RUAR	25	
			POTR	30	
			BUDA	20	
	Middle of bank	Some riprap with exposed soil	FRLA	10	Scattered trees and saplings
			RUAR	60	
			BUDA	20	
Toe of bank	Piles, riprap, gravels, and fines	SYLA	10	Aster rooted in the piles	
4.9E-b	Top of bank	25% riprap, 25% steep soil	PICO	20	Mix of trees and shrubs
			RUAR	25	
			POTR	50	
			FRLA	5	
	Middle of bank	Soil with rock	RUAR	50	-
	Toe of bank	Piles, riprap, gravel, and fines	SYLA	5	Aster rooted in piles, algal mat on riprap
			JUEF	5	
			IRPS	10	
			POPA	10	
	4.9E-c	Top of bank	75% soil, 20% riprap, 5% piles	PSME	25
ACMA				40	
RUAR				25	
Middle of bank		Steep exposed soil	RUAR	40	
			LELA	10	
			HYPE	10	
Toe of bank		High tide bench with piles	IRPS	5	
			POPA	10	
			ALPL	5	
4.9E-d	Top of bank	Concrete slabs and large riprap	SALA	50	Large debris
			FRLA	50	
	Middle of bank	Concrete slab and large riprap	RUAR	20	80% bare ground
			BUDA	5	
	Toe of bank	Concrete slab and large	CALY	5	Algal mat on riprap
			SYLA	5	

Notes:

1. This represents the closest river mile to the midpoint of the Phase I RAL exceedance area. Additionally, the side of the bank (i.e., east or west) is included for reference.

RAL: remedial action level

2 References

Windward, Anchor QEA. 2020. Lower Duwamish Waterway quality assurance project plan for remedial design of Upper Reach: pre-design investigation. Final. Submitted to EPA May 19, 2020. Windward Environmental LLC and Anchor QEA, Seattle, WA.

3 Attachments

Attachment I-1 Photographs

FINAL

Attachment I-1

Photographs

Photograph I-1
Representative Vegetation Conditions at RM 3.5W



Photograph I-2
Representative Vegetation Conditions at RM 3.8E-a



Photograph I-3
Representative Vegetation Conditions at RM 3.8W-b



Photograph I-4
Representative Vegetation Conditions at RM 3.8E-c



Photograph I-5
Representative Vegetation Conditions at RM 3.8W-d



Photograph I-6
Representative Vegetation Conditions at RM 3.9E



Photograph I-7
Representative Vegetation Conditions at RM 4.0E



Photograph I-8
Representative Vegetation Conditions at RM 4.1E



Photograph I-9
Representative Vegetation Conditions at RM 4.2E



Photograph I-10
Representative Vegetation Conditions at RM 4.6E



Photograph I-11
Representative Vegetation Conditions at RM 4.7W



Photograph I-12
Representative Vegetation Conditions at RM 4.8W



Photograph I-13
Representative Vegetation Conditions at RM 4.9E-a



Photograph I-14
Representative Vegetation Conditions at RM 4.9E-b



Photograph I-15
Representative Vegetation Conditions at 4.9E-c



Photograph I-16
Representative Vegetation Conditions at RM 4.9E-d



Attachment E.6

Habitat Evaluation

Lower Duwamish Waterway Group

Port of Seattle / City of Seattle / King County / The Boeing Company

HABITAT EVALUATION FOR LOWER DUWAMISH WATERWAY UPPER REACH REMEDIAL DESIGN

For submittal to

U.S. Environmental Protection Agency

Seattle, WA

July 25, 2023

Prepared by:



1201 3rd Avenue • Suite 2600
Seattle, Washington • 98101

in association
with



200 West Mercer Street • Suite 401
Seattle, Washington • 981199

TABLE OF CONTENTS

1	Introduction	1
1.1	Purpose of the Habitat Evaluation.....	1
2	Habitat Evaluation Methods	3
2.1	Existing Habitat Conditions.....	3
2.1.1	Shoreline Bank Habitat Data Collection	3
2.1.2	Other Sources of Habitat Data.....	5
2.2	Post-Remediation Habitat Conditions	5
2.3	Data Processing and Mapping.....	6
2.4	Puget Sound Nearshore Calculator.....	7
2.5	Semi-Quantitative Habitat Evaluation.....	8
3	Results.....	10
4	References	13

TABLES

Table E.6.2-1	Existing Habitat Data to Be Used as Inputs to the Habitat Evaluation.....	5
Table E.6.3-1	PNSC Habitat Evaluation Results.....	11
Table E.6.3-2	Summary of Semi-Quantitative Habitat Evaluation Results.....	12

ATTACHMENTS

- Attachment E.6.1 Remedial Technology Assignments
- Attachment E.6.2 PSNC Workbook 1 of 2
- Attachment E.6.3 PSNC Workbook 2 of 2
- Attachment E.6.4 Pile Removal Information

ABBREVIATIONS

BA	<i>Biological Assessment for the Lower Duwamish Waterway Upper Reach</i>
BODR	<i>Basis of Design Report</i>
DER	<i>Pre-Design Investigation Data Evaluation Report for the Lower Duwamish Waterway</i>
DSAY	discounted service acre-year
Ecology	Washington State Department of Ecology
ENR	enhanced natural recovery
EPA	U.S. Environmental Protection Agency
ESA	Endangered Species Act
FNC	federal navigation channel
HEA	Habitat Equivalency Analysis
LDW	Lower Duwamish Waterway
LDWG	Lower Duwamish Waterway Group
MHHW	mean higher high water
MLLW	mean lower low water
NMFS	National Marine Fisheries Service
NOAA	National Oceanic and Atmospheric Administration
NHVM	Nearshore Habitat Values Model
PDI	pre-design investigation
PSNC	Puget Sound Nearshore Calculator
QAPP	<i>Quality Assurance Project Plan</i>
RAA	remedial action area
RAL	remedial action level
RD	remedial design
RMC	residuals management cover
ROD	<i>Record of Decision</i>
SSNP	Salish Sea Nearshore Programmatic
USFWS	U.S. Fish and Wildlife Service

1 Introduction

The Lower Duwamish Waterway Group (LDWG), in coordination with the U.S. Environmental Protection Agency (EPA) and Washington State Department of Ecology (Ecology), is proposing an in-water cleanup remedy for the upper reach of the Lower Duwamish Waterway (LDW) Superfund Site in King County, Washington. The upper reach extends from river miles 3 to 5. EPA and Ecology have divided lead agency responsibility for addressing the site as follows: EPA is responsible for administering the cleanup of the sediments in the waterway, and Ecology is responsible for controlling sources of pollution to the waterway. The proposed action will remediate contaminated sediments that are a result of over a century of urbanization and industrial activity on the LDW. The proposed action implements the EPA's remedy as specified in the LDW *Record of Decision* (ROD) and the *Explanation of Significant Differences* (EPA 2014, 2021).

This habitat evaluation attachment to the *Biological Assessment for the Lower Duwamish Waterway Upper Reach* (BA) is prepared based on the 60% remedial design (RD) for the upper reach and is intended to demonstrate substantive compliance for this federal cleanup action under the Endangered Species Act (ESA), and the Magnuson-Stevens Fishery Conservation and Management Act. Separate BAs will be prepared for subsequent cleanup phases (middle and lower reaches).

1.1 Purpose of the Habitat Evaluation

The purpose of this habitat evaluation is to determine impacts to habitat from implementing the remedial activities within each remedial action area (RAA; BA Figures E2-3a and E2-3b). As described in Section 11.6 of the Intermediate (60%) RD *Basis of Design Report* (BODR; Anchor QEA and Windward 2023), the impact of remedial activities to all habitat types, including the ROD-defined "habitat areas"¹ (EPA 2014), is being evaluated to help comply with Section 404 of the Clean Water Act and Section 7 of the ESA. The results of the habitat evaluation will determine if the remedial activities are expected to improve or degrade habitat conditions relative to existing conditions and will be used to support the evaluation of threatened and endangered species and habitats associated with the remedial activities.

Mitigation may be required to offset unavoidable adverse impacts to habitat, but this will be evaluated across all reaches (upper, middle, and lower) of the LDW. The design for the upper reach will seek to maintain net habitat value and avoid the need for mitigation to the extent possible. Additionally, it is anticipated that the future design for the middle and lower reaches will also seek to avoid the need for mitigation to the extent possible, which will be confirmed by conducting the same habitat evaluation for middle and lower reaches as the RD progresses for those reaches. The

¹ The ROD defines "habitat areas" as all areas with elevations between -10 feet mean lower low water (MLLW) and the mean higher high water (MHHW) elevation of +11.3 feet MLLW to provide design requirements for remedial activities that occur within those elevations.

resulting habitat impacts or benefits will be determined for each reach. The intent of this approach is to use potential credits generated in one reach to offset potential impacts estimated in another reach, such that mitigation will be unnecessary across all three reaches of the LDW. Because the upper reach is the first project to be designed and constructed, it is the intent of the upper reach design to result in net neutral or positive habitat credit. If it is determined that mitigation is needed after considering all three reaches of the LDW, a draft and final Compensatory Mitigation Plan will be included in the RD submittals for the lower reach.

The remainder of this document describes the habitat evaluation methods and results.

2 Habitat Evaluation Methods

The habitat evaluation was completed using the Puget Sound Nearshore Calculator (PSNC) to determine potential habitat impacts from specific activities included in the in-water cleanup remedy for the upper reach of the LDW. Specific activities that could result in either the loss of or the gain of nearshore habitat functions and values to ESA-listed species and their designated critical habitat include piling removal and replacement, creosote removal, bulkhead reinforcement, debris removal, and riparian disturbance. The PSNC implements a Habitat Equivalency Analysis (HEA) methodology to assess impacts and benefits to the habitat consistent with the Salish Sea Nearshore Programmatic (SSNP) Biological Opinion (NOAA 2022). The National Oceanic and Atmospheric Administration's (NOAA's) National Marine Fisheries Service (NMFS) and the U.S. Fish and Wildlife Service (USFWS) developed the PSNC as a user-accessible tool to quantify habitat impacts and facilitate avoidance, minimization, and, where warranted or otherwise appropriate, no-net loss of nearshore habitat functions relevant for Puget Sound nearshore environments and species (Ehinger et al. 2023).

As described in the SSNP Biological Opinion, other remedial activities in the upper reach of the LDW that may not require conservation offsets and are not included in the PSNC include dredging, excavation, capping, or other methods of removing or isolating contaminated sediments from aquatic habitats. Contaminated sediment removal activities are not included because they are expected to result in permanent habitat improvement (NOAA 2022). Instead, a semi-quantitative comparison of existing habitat conditions to expected post-remediation conditions was performed for these activities. Overall, the habitat evaluation steps included the following:

- Establish existing habitat conditions.
- Establish post-remediation habitat conditions.
- Conduct a quantitative habitat evaluation for remedial activities included in the PSNC.
- Conduct a semi-quantitative evaluation for remedial activities not included in the PSNC.

2.1 Existing Habitat Conditions

This section describes how existing habitat conditions were established, including data collection for shoreline bank conditions. Existing habitat data and habitat categories to be used are summarized in Table E.6.2-1, and existing habitat conditions are shown in BA Figures E2-2a and E2-2b.

2.1.1 Shoreline Bank Habitat Data Collection

Shoreline bank habitat data collection was performed during visual bank inspections for Phase I and Phase II pre-design investigations (PDIs), and results were presented in the final *Pre-Design Investigation Data Evaluation Report for the Lower Duwamish Waterway – Upper Reach* (DER;

Anchor QEA and Windward 2022). Details of the shoreline bank habitat and vegetation data collection methods during Phase I and Phase II are described in the following sections.

2.1.1.1 Phase I

The Phase I bank visual inspection was conducted building upon the existing LDW waterway user survey (Integral et al. 2018). Detailed methods to collect visual bank data were presented in the PDI *Quality Assurance Project Plan* (QAPP; Anchor QEA and Windward 2019).

Phase I bank inspection of the entire upper reach was conducted primarily by boat around daytime low tides (2 hours before and 2 hours after) on June 11, 16, 18, 23, and 26, and August 4, 2020. The inspection included the collection of videos, photographs, and detailed observations to document eastern and western bank conditions along the upper reach. Inspections occurred at various times throughout the day to provide varying lighting conditions to capture photographs of both sides of the waterway. Detailed observations collected included shoreline station (as defined in the LDW waterway user survey [Integral et al. 2018]), bank type and characteristics, above-bank (above mean higher high water [MHHW]) vegetation presence, and vegetation details. Bank types were defined as one of the following: armored, unarmored, or bulkheaded (Figure E4-2 of the BA). Unarmored banks included those with exposed sediment, random armoring, and/or vegetation. Bank characteristics included vegetation presence, slope, erosion, and general condition. Bank and above-bank vegetation (above MHHW) details included percent cover and plant species for tree, shrub, and grass/herbaceous communities. Full results of the Phase I visual bank inspection are presented in Appendix E of the final DER (Anchor QEA and Windward 2022).

2.1.1.2 Phase II

A visual inspection of shoreline vegetation along the upper reach of the LDW was conducted by boat on June 20 and July 1, 2021, as part of the Phase II PDI. This inspection built on the information collected during the Phase I PDI visual bank inspection but focused only on areas where remediation was anticipated to occur. The inspection included the collection of photographs and detailed observations to document shoreline vegetation within the Phase I remedial action level (RAL) exceedance areas along the upper reach. At each Phase I RAL exceedance area, photographs were taken, and observations were recorded to document vegetation types. Vegetation details included percent cover and plant species for tree, shrub, and grass/herbaceous communities. Typically, observations were made for the top of bank (above MHHW), middle of bank (intertidal portion of bank below MHHW and above the toe of bank), and toe of bank (area below bank observed during the low-tide inspections); however, observations were split into subareas if needed, to capture distinct shoreline conditions. Full vegetation observations collected in the Phase II visual bank inspection are presented in Appendix I of the DER (Anchor QEA and Windward 2022).

2.1.2 Other Sources of Habitat Data

Bathymetric, topographic, bank feature, geotechnical, and structure inspection data were collected as part of the Phase I and Phase II PDIs and are used to further establish existing habitat conditions. Other data used to support the habitat evaluation collected during Phase I and II PDIs included visual structure inspections, geotechnical investigations, and topographic survey results (Attachment E.6.1). These investigations are detailed in the DER and supporting appendices (Anchor QEA and Windward 2022).

**Table E.6.2-1
Existing Habitat Data to Be Used as Inputs to the Habitat Evaluation**

Habitat Data Sources				
Characteristics	Shoreline Bank Visual Observations ¹	Bathymetry and Topography ²	Aerial Imagery ³	Sediment and Substrate ⁴
Vegetation	x		x	
Natural Substrate ⁵	x		x	x
Artificial Substrate ⁶	x		x	x
Structures ⁷	x		x	
Paved Areas, Buildings	x		x	
Elevation		x		

Notes:

1. Including habitat, vegetation, structures, and bank features observations (Anchor QEA and Windward 2023)
2. Anchor QEA and Windward 2020, 2021
3. King County 2021
4. Phase I and Phase II geotechnical investigations as described in the final DER (Anchor QEA and Windward 2022)
5. Natural substrate includes rounded gravel and finer substrates and natural rock outcrop.
6. Artificial substrate includes angular rock, riprap, or anthropogenic debris (e.g., slag).
7. Structures include overwater structures (wharfs, piers, docks, etc.), in-water structures (piles, pile groups, dolphins, etc.), and shoreline structures and utilities (outfalls, bulkheads, wing walls, etc.).

DER: *Pre-Design Investigation Data Evaluation Report for the Lower Duwamish Waterway*

2.2 Post-Remediation Habitat Conditions

Post-remediation habitat conditions were determined based on the remedial technologies assigned to each RAA as shown in BA Figures E6-1a and E6-1b. Remedial technologies include dredge/excavation; engineered cap, placement of backfill, residuals management cover (RMC), enhanced natural recovery (ENR), and amended cover material; and in-water structure modification, as described in Section 2 of the *Biological Assessment for the Lower Duwamish Waterway Upper Reach* (BA). RAL exceedance areas were the basis for the RAAs that are inclusive of the expected area of impact (e.g., includes dredging side slopes), including the RMC placement areas in the dredge perimeter. A conservative 40-foot outer dredge perimeter for RMC was included around each RAA to

account for both post-dredging residuals and contingency dredge area (BA Figures E2-3a and E2-3b). For this evaluation, remedial activities were from Table 5-1 of the Intermediate (60%) RD BODR (Anchor QEA and Windward 2023) and anticipated changes from Phase III sampling, and expected post-construction habitat (i.e., substrate and elevation conditions) was determined based on Attachment E.6.1. Additional details about the types of remedial and construction activities are included in Section 2.2 of the BA.

Overall, approximately 28.1 acres of the approximately 132-acre upper reach could be impacted by remedial activities, including dredging; engineered capping; and placement of backfill, RMC, ENR, and amended cover materials, as summarized in Table E.6.3-1. Additionally, up to thirty 10-inch timber piles are expected to be removed, and up to two 14-inch steel pipe piles are expected to be installed as replacements (Table E.6.3-2). Fifteen of the 10-inch timber piles that are expected to be removed are assumed to be creosote-treated. This results in a net gain of 14.22 square feet of intertidal habitat from the permanent decrease in pile areal coverage. Approximately 10 temporary piles may be installed during construction for moorage in deep subtidal areas outside of the federal navigation channel (FNC). The reinforcement of an existing bulkhead wall results in a loss of 240 square feet of intertidal habitat. Finally, 0.05 acre (2,160 square feet) of bank protection is expected to be permanently placed at outfalls to protect the remediated bank from erosion. These areas will be within areas of dredging and/or material placement, so they will not be new areas of construction impact. Overall, 2,386 square feet (net) will be impacted by in-water structure modifications (Table E2-2 of the BA).

2.3 Data Processing and Mapping

All available data sources, including visual habitat observations of habitat types and plant species, bank features and structures, bathymetry, topography, geotechnical (substrate), and aerial imagery, were imported to GIS mapping software. The resulting habitat polygons were assigned an elevation-based habitat category relative to mean lower low water (MLLW) ("Existing Habitat Conditions," BA Figures E2-2a and E2-2b). Post-remediation habitat conditions were then assigned based on engineering design details for each RAA plus its RMC perimeter. For the semi-quantitative evaluation, spatial analysis tools were used to reassign habitat categories in each RAA (plus RMC) based on changes to elevation and substrate type that would occur because of remedial activities ("Post-Remediation Habitat Conditions," BA Figures E6-1a and E6-1b). Design details extracted for the PSNC included length and diameter of pilings, length and elevation of shoreline armoring removal and replacement, area and elevation of debris removal, and area of riparian disturbance. Project information and design details required for the PSNC are documented in Attachments E.6.2, E.6.3, and E.6.4.

2.4 Puget Sound Nearshore Calculator

The PSNC uses HEA and the Nearshore Habitat Values Model (NHVM) to facilitate determination of the following: 1) habitat impacts resulting from nearshore projects that decrease habitat function; and 2) habitat benefits, which are associated with projects that increase nearshore habitat function (Ehinger et al. 2023). HEA is an accounting technique for calculating the replacement of lost ecological services (defined as functions and values that a habitat provides) resulting from an impact (NOAA 1995; Ray 2009). It is a generalized method that can be used in any type of habitat, including freshwater rivers and streams, salt marshes, seagrass beds, and coral reefs. The accounting metric used in HEA is discounted service acre-years (DSAYs), which is a measure of the resource service flows provided by various habitats over time.

The NHVM defines habitat values in terms of physical and biological functions of salmonid critical habitat as defined in 50 Code of Federal Regulations 226.212 (Ehinger et al. 2023). As described in the BA, elements of salmonid critical habitat include the unobstructed migratory corridor, cover and primary production, sediment quality and quantity, and water quality. The NHVM defines habitat values for four major elevation zones including the Riparian Zone, the Upper Shore Zone, the Lower Shore Zone, and the Deep Shore Zone, which are used in the PSNC. More information on HEA and the NHVM can be found in the Puget Sound Nearshore Habitat Calculator User Guide (Ehinger et al. 2023).

The PSNC is available at the NMFS Puget Sound Nearshore Habitat Conservation Calculator website as an excel workbook (NOAA 2023). Two workbooks used to evaluate LDW Upper Reach remedial activities are included with this document as Attachment E.6.2 (PSNC Workbook 1 of 2) and Attachment E.6.3 (PSNC Workbook 2 of 2). Additional information on pile installation and removal is included in Attachment E.6.4. The PSNC workbooks were used to evaluate actions associated with LDW upper reach remedial activities on the following tabs:

- **Summary (Workbook 1 of 2) – Puget Sound Nearshore Habitat Conservation Calculator:** This tab provides a summary of habitat debits and credits (impacts and benefits) for activities evaluated in Workbook 1.
- **Summary (Workbook 2 of 2) – Puget Sound Nearshore Habitat Conservation Calculator:** This tab provides a summary of habitat debits and credits (impacts and benefits) for activities evaluated in Workbook 2.
- **ProjectD (Workbook 1 of 2) – Project Details:** This tab provides project details including location, project description, and site-specific factors, as well as design details and assumptions for remediation activities evaluated in Workbook 1.
- **ProjectD (Workbook 2 of 2) – Project Details:** This tab provides project details including location, project description, site-specific factors, as well as design details and assumptions for remediation activities evaluated in Workbook 2.

- **RZ (Workbook 1 of 2)– Habitat Impact and Determination for the Riparian Zone:** This tab was used to quantify riparian disturbance in RAA 27 during construction.
- **RZ (Workbook 2 of 2)– Habitat Impact and Determination for the Riparian Zone:** This tab was used to quantify riparian planting in RAA 27 after construction. The evaluation included the assumption that riparian bank areas of RAA 27 that are currently riprap/debris with non-native shrub species will be capped and replanted with native species.
- **Overwater Structures (Workbook 1 of 2)– Impact and Benefit Determination for Overwater Structure:** This tab was used to quantify piling removal and replacement in RAAs 24/25, 26, 27, 30/31, 32, and 33/34/35 and creosote removal in RAAs 24/25, 26, 27, and 30/31.
- **BoatR, Jetty (Workbook 1 of 2)– Impact and Determination for Concrete Boat Ramps, Jetties, and Concrete Rubble:** This tab was used to quantify debris removal and waterward reinforcement of an existing bulkhead in RAA 22.

2.5 Semi-Quantitative Habitat Evaluation

As described in the SSNP Biological Opinion (NOAA 2022), methods of removing or isolating contaminated sediments from aquatic habitats (e.g. dredging, excavation, capping) that are performed, ordered, or sponsored by government agency with established legal or regulatory authority are not included in the PSNC. Therefore, a semi-quantitative habitat evaluation was performed for this category of remedial activities by comparing the existing habitat conditions to the expected post-remediation habitat conditions. The qualitative evaluation was used in the BA as a systematic way to determine the level of habitat benefit or habitat impact related to remedial activities not considered in the PSNC. Habitat categories in the semi-quantitative evaluation were defined by elevations referenced to MLLW based on the bathymetric and topographic data collected as part of the Phase I and II PDIs. Habitat categories used for the habitat evaluation included the following:

- **Deep Subtidal:** Deeper than -10 feet MLLW
- **Shallow Subtidal:** Between -10 and -4 feet MLLW
- **Lower Intertidal:** Between -4 and +4 feet MLLW
- **Upper Intertidal:** Between +4 and +11.3 feet MLLW
- **Vegetated Buffer²:** Above +11.3 feet MLLW

Consistent with the ROD (EPA 2014), the semi-quantitative evaluation confirmed that no elevation-based habitat type changes occurred because of remedial activities (e.g. Intertidal to Subtidal habitat). Additionally, the descriptor “degraded” was applied to some areas of habitat. For the purposes of the habitat evaluation, degraded habitat types refer to those with overwater structures, riprap and/or debris, or adjacent to a bulkhead wall. The habitat type immediately

² Vegetated buffer is assumed to extend 400 feet upland or until a paved surface and is not expected to be impacted by remediation construction.

adjacent to the bulkhead wall is considered degraded. In some instances this is the upper intertidal area and in some instances this is the lower intertidal area. The degraded status of each RAA-based habitat area was reviewed for pre- and post-remediation conditions.

3 Results

The results of the PSNC portion of the habitat evaluation are reported in DSAYs, where a DSAY represents the value of all the ecosystem services provided by 1 acre of habitat over 1 year. A negative DSAY indicates a habitat impact; a positive DSAY indicates a habitat benefit. The habitat evaluation compared baseline habitat conditions to the post-remediation habitat conditions for activities including pile installation and removal, creosote removal, bulkhead reinforcement, debris removal, and riparian disturbance and replanting. These activities are reported as habitat impacts and benefits (debits and credits) in Table E.6.3-1. The project is expected to result in habitat impacts of -0.45 DSAYs related to piling installation, waterward shoring reinforcement of an existing bulkhead in RAA 22, and riparian disturbance in RAA 27. The project is expected to result in habitat benefits of 1.50 DSAYs related to piling and creosote removal, debris removal in RAA 22, and planting of native vegetation in RAA 27. Overall, project remediation activities are expected to result in a net 1.05 DSAYs of habitat benefit.

The semi-quantitative habitat evaluation of sediment chemical remediation activities, including dredging and capping, shows that no changes in habitat type (e.g., from intertidal to shallow subtidal) are expected in 98% of the remediation areas. Changes in habitat elevation and/or degradation status³ are expected to occur in a total of 0.33 acre in RAAs 22, 29, 32, and 33/34/35 (Table E.6.3-2). A change from Degraded Upper Intertidal to Degraded Lower Intertidal in RAA 22 is related to removal of delineated debris piles. In RAA 22, the two debris piles are adjacent to a bulkhead wall and in the upper intertidal zone. After the debris piles are removed, the areas will also change to lower intertidal and will be degraded because the areas will be adjacent to a bulkhead wall. However, the benefit related to the debris pile removal is quantified by the PSNC, as previously described. Removal of scattered riprap and debris in RAA 29 from dredging will result in a habitat change from Degraded Upper Intertidal to Upper Intertidal. Removal of scattered riprap and debris in RAAs 32 and 33/34/35 from dredging will result in habitat changes from Degraded Upper and Lower Intertidal to Upper and Lower Intertidal. In the engineered cap area in RAA 27, the existing substrate consists of riprap and debris within the cap area. Because the surface substrate in this area would be riprap armor, there is no change in substrate type post-remediation. In the engineered cap area in RAA 14/15/16, riprap armor will also be placed in a deep subtidal area that is expected to quickly fill in with native material and cover the riprap. As such, no permanent change in substrate type is expected in this area. The semi-quantitative habitat evaluation results indicate that there will be project-related habitat benefits from incidental debris/riprap removal. These benefits would be in addition to benefits quantified with the PSNC and the expected permanent benthic habitat, sediment quality, and water quality improvements from sediment chemical remediation.

³ Degradation refers to habitat with overwater structures, riprap and/or debris, or that is adjacent to a bulkhead wall.

Consideration of both the PSNC calculations and the semi-quantitative evaluation of sediment remediation areas shows that conservation offsets are not expected for the upper reach of the LDW. There is expected to be up to 1.05 DSAYs of project-related habitat benefit and net improvement of nearshore habitat functions and values to ESA-listed species and their designated critical habitat related to the project.

**Table E.6.3-1
PNSC Habitat Evaluation Results**

Habitat Change Type	Conservation Credit/Debit	Conservation Credit/Debit Description	RAA	DSAYs
Overwater Structures	Debit	Piling Installation	24/25, 26, 27	-0.01
	Credit	Piling Removal (Including creosote removal)	24/25, 26, 27, 30/31, 32, 33/34/35 (24/25, 26, 27, 30/31)	0.07
Boat Ramps, Jetties, and Rubble	Debit	Waterward Reinforcement of Existing Bulkhead	22	-0.09
	Credit	Debris Pile Removal	22	0.12
Riparian Vegetation	Debit	Removal of Riparian Vegetation During Construction	27	-0.35
	Credit	Planting of Riparian Vegetation After Construction	27	1.31
Total DSAYs				1.05

Notes:

PNSC: Puget Sound Nearshore Calculator

RAA: remedial action area

DSAY: discounted service acre-year

**Table E.6.3-2
Summary of Semi-Quantitative Habitat Evaluation Results**

RAA	Pre-Construction Habitat Type	Post-Construction Habitat Type	Area (acres)	Description of Change
22	Degraded Upper Intertidal	Degraded Lower Intertidal	0.03	Removal of delineated debris pile adjacent to bulkhead wall. This change is considered quantitatively in the PSNC evaluation.
22	Degraded Upper Intertidal	Degraded Lower Intertidal	0.01	Removal of delineated debris pile adjacent to bulkhead wall. This change is considered quantitatively in the PSNC evaluation.
29	Degraded Upper Intertidal	Upper Intertidal	0.08	Removal of scattered riprap/debris during sediment remediation dredging
32/33/34/35 ¹	Degraded Lower Intertidal	Lower Intertidal	0.17	Removal of scattered riprap/debris during sediment remediation dredging
32/33/34/35 ¹	Degraded Upper Intertidal	Upper Intertidal	0.01	Removal of scattered riprap/debris during sediment remediation dredging
32/33/34/35 ¹	Degraded Upper Intertidal	Upper Intertidal	0.03	Removal of scattered riprap/debris during sediment remediation dredging
Total			0.33	

Notes: For the purposes of the habitat evaluation, degradation refers to habitat with overwater structures, riprap and/or debris, or that is adjacent to a bulkhead wall.

RAA: Remedial Action Area

1. Areas for RAAs 32 and 33/34/35 overlapped when the conservative 40-foot outer dredge perimeter was included around each RAA to account for both post-dredging residuals and contingency dredge area.

4 References

- Anchor QEA and Windward (Anchor QEA, LLC; Windward Environmental LLC), 2019. *Quality Assurance Project Plan: Pre-Design Surveys of the Lower Duwamish Waterway Upper Reach*. Final. Submitted to EPA April 11, 2019.
- Anchor QEA and Windward, 2020. *Quality Assurance Project Plan for the Lower Duwamish Waterway Upper Reach: Pre-Design Investigation*. Final. Submitted to EPA May 19, 2020
- Anchor QEA and Windward, 2021. *Quality Assurance Project Plan Addendum for the Lower Duwamish Waterway Upper Reach: Pre-Design Investigation Phase II*. Final. Submitted to EPA June 25, 2021.
- Anchor QEA and Windward, 2022. *Pre-Design Investigation Data Evaluation Report for the Lower Duwamish Waterway – Upper Reach*. Final. Submitted to EPA July 15, 2022.
- Anchor QEA and Windward, 2023. *Intermediate (60%) Remedial Design Basis of Design Report for Lower Duwamish Waterway Upper Reach*. Submitted to EPA February 20, 2023.
- Ehinger, S. I., L. Abernathy, M. Bhuthimethee, L. Corum, N. Rudh, D. Price, J. Lim, M. O'Connor, S. Smith, J. Quan, 2023. Puget Sound Nearshore Habitat Calculator User Guide V1.5. NOAA, editor. Accessed via. <https://www.fisheries.noaa.gov/west-coast/habitat-conservation/puget-sound-nearshore-habitat-conservation-calculator>
- EPA (U.S. Environmental Protection Agency), 2014. *Record of Decision*. Lower Duwamish Waterway Superfund Site (WA0000232980). EPA Region 10. November 2014.
- EPA, 2021. *Programmatic Biological Assessment, Portland Harbor Superfund Site*. U.S. Environmental Protection Agency, Region 10, Seattle, Washington. July 2021.
- Integral (Integral Consulting, Inc.), Moffatt & Nichol, and Windward Environmental LLC, 2018. *Waterway User Survey and Assessment of In-Water Structures – Data Report*. Prepared for U.S. Environmental Protection Agency, Region 10. July 2, 2018.
- King County, 2021. WA – King County – Aerial (2021). Available at: https://gismaps.kingcounty.gov/arcgis/rest/services/BaseMaps/KingCo_Aerial_2021/MapServer.
- NOAA (National Oceanic and Atmospheric Administration), 1995. *Habitat Equivalency Analysis: An Overview*. NOAA Damage Assessment and Restoration Program, Department of Commerce. Washington, DC. March 21, 1995.

NOAA, 2022. Endangered Species Act (ESA) Section 7(a)(2) Biological Opinion and Magnuson–Stevens Fishery Conservation and Management Act Essential Fish Habitat Response for the Salish Sea Nearshore Programmatic Consultation (SSNP). NMFS consultation number WCRO-2019-04086. June 29, 2022.

NOAA, 2023. Puget Sound Nearshore Habitat Conservation Calculator. Available at:
<https://www.fisheries.noaa.gov/west-coast/habitat-conservation/puget-sound-nearshore-habitat-conservation-calculator>

Ray, G.L., 2009. *Application of Habitat Equivalency Analysis to USACE Projects*. Ecosystem Management and Restoration Research Program (EMRRP). ERDC TN-EMRRP-EI-04. April 2009.

Attachment E.6.1

Remedial Technology Assignments

Attachment E.6.1

Intermediate (60%) Remedial Technology Assignments by RAA

Remedial Action Area¹	Area (acreage)	Intermediate 60% Design Remedial Technology Assignment^{2,3}	Notes
1/2/3	2.42	Dredge and Backfill	Elevations shallower than -10 MLLW will be backfilled to grade.
		Dredge	Elevations deeper than -10 MLLW will not be backfilled to grade, but RMC material will be placed.
4/5	4.24	Dredge and Backfill	Elevations shallower than -10 MLLW and outside the FNC will be backfilled to grade.
		Dredge	Areas within the FNC or elevations deeper than -10 MLLW will not be backfilled to grade, but RMC material will be placed.
6	0.03	Dredge	Elevations deeper than -10 MLLW will not be backfilled to grade, but RMC material will be placed.
7	0.03	ENR	ENR material to be placed on existing mudline.
8	0.03	Dredge and Backfill	Elevations shallower than -10 MLLW will be backfilled to grade.
10	0.04	ENR	ENR material to be placed on existing mudline.
11	0.10	Dredge and Backfill	Elevations shallower than -10 MLLW and outside the FNC will be backfilled to grade.
12	0.03	Dredge	Areas within the FNC or elevations deeper than -10 MLLW will not be backfilled to grade, but RMC material will be placed.
13	0.07	Dredge	Areas within the South Park Marina will not be backfilled to grade, but RMC material will be placed.
	0.09	ENR	ENR material will be placed over existing riprap slope.
14/15/16 ⁴	1.2	Dredge and Backfill	Elevations shallower than -10 MLLW will be backfilled to grade.
		Partial Dredge and Engineered Cap	Areas within the FNC or elevations deeper than -10 MLLW will not be backfilled to grade, but RMC material will be placed.
17	0.11	Dredge	Areas within the FNC or elevations deeper than -10 MLLW will not be backfilled to grade, but RMC material will be placed.
18	0.54	Dredge and Backfill	Elevations shallower than -10 MLLW will be backfilled to grade.
	0.02	Area-Specific Technology B: Amended Cover	Amended cover material will be placed on existing mudline in structural offset areas.
	0.009	Slag Pile Removal	Slag pile will be removed.
19/20	0.16	Dredge and Backfill	Elevations shallower than -10 MLLW will be backfilled to grade.
21	0.07	Dredge and Backfill	Elevations shallower than -10 MLLW will be backfilled to grade.
22	0.62	Dredge and Backfill	Elevations shallower than -10 MLLW will be backfilled to grade.
		Dredge	Elevations deeper than -10 MLLW will not be backfilled to grade, but RMC material will be placed.

Remedial Action Area ¹	Area (acreage)	Intermediate 60% Design Remedial Technology Assignment ^{2,3}	Notes
	0.41	Slag Pile Removal	Two large debris piles will be removed.
23	0.06	ENR	ENR material will be placed on existing mudline.
24/25	0.20	Dredge and Backfill	Elevations shallower than -10 MLLW will be backfilled to grade.
	0.03	Area-Specific Technology B: Amended Cover	Amended cover material will be placed in structural offset area.
	0.08	ENR	ENR material will be placed on existing mudline.
26	0.22	Dredge and Backfill	Elevations shallower than -10 MLLW will be backfilled to grade.
	0.07	Area-Specific Technology B: Amended Cover	Amended cover material will be placed on existing riprap slope.
27	1.88	Dredge and Backfill	Elevations shallower than -10 MLLW will be backfilled to grade.
	0.35	Partial Dredge and Engineered Cap	Engineered cap may be placed along the bank slope.
28	0.22	Dredge	Berth areas will not be backfilled to grade.
29	0.15	Dredge and Backfill	Elevations shallower than -10 MLLW will be backfilled to grade.
30	0.04	Dredge and Backfill	Elevations shallower than -10 MLLW will be backfilled to grade.
31	0.05	Dredge and Backfill	Elevations shallower than -10 MLLW will be backfilled to grade.
32	0.07	Dredge and Backfill	Elevations shallower than -10 MLLW will be backfilled to grade.
33/34/35	0.05	ENR	ENR material will be placed on existing mudline.
	0.35	Dredge and Backfill	Elevations shallower than -10 MLLW will be backfilled to grade.
ENR (cPAH only) Areas ⁵	0.17	ENR	ENR material will be placed on existing mudline.

Notes:

Backfill means backfill to restore approximate pre-construction elevations.

1. RAA 9 is removed for 90% RD.
2. From Intermediate (60%) RD BODR, Section 10.2.9: all dredge areas located outside of the FNC and above elevation -10 feet MLLW will be backfilled to grade using suitable habitat material consisting of a mix of sand and gravel (Anchor QEA and Windward 2023)
3. From Intermediate (60%) RD BODR, Section 3.7.3, ENR is 12 inches of sand/gravel placed on existing mudline (Anchor QEA and Windward 2023).
4. The one exception in this table to the remedial technology assignment from the 60% RD is for RAA 14/15/16. Preliminary Phase III PDI data indicate that this area will expand both horizontally and vertically. For BA evaluation purposes, the anticipated larger area footprint has been assumed for this area.
5. See Appendix C of the 60% RD BODR for further discussion regarding the cPAH-only area. This area will be treated the same as the other ENR areas identified in this table.

BA: *Biological Assessment*

cPAH: carcinogenic polycyclic aromatic hydrocarbon

ENR: enhanced natural recovery

FNC: federal navigation channel

MLLW: mean lower low water

RAA: remedial action area

RD: remedial design

RMC: residuals management cover

Attachment E.6.2

PSNC Workbook 1 of 2

Provided as Excel file

Attachment E.6.3

PSNC Workbook 2 of 2

Provided as Excel file

Attachment E.6.4

Pile Removal Information

BORDER FILE EDITION: x:\KOV\DW\DW-Size-TB-Border_AQB\layer
 \g:\a\c\p\projects\0067-King County\LDW Upper Reach Engineering Services\Construction Plans\0067-LDWUR-PL-Existing Conditions.dwg | Layout: V106
 PLOTTED: Feb 20, 2023 12:39:06am By tgriga

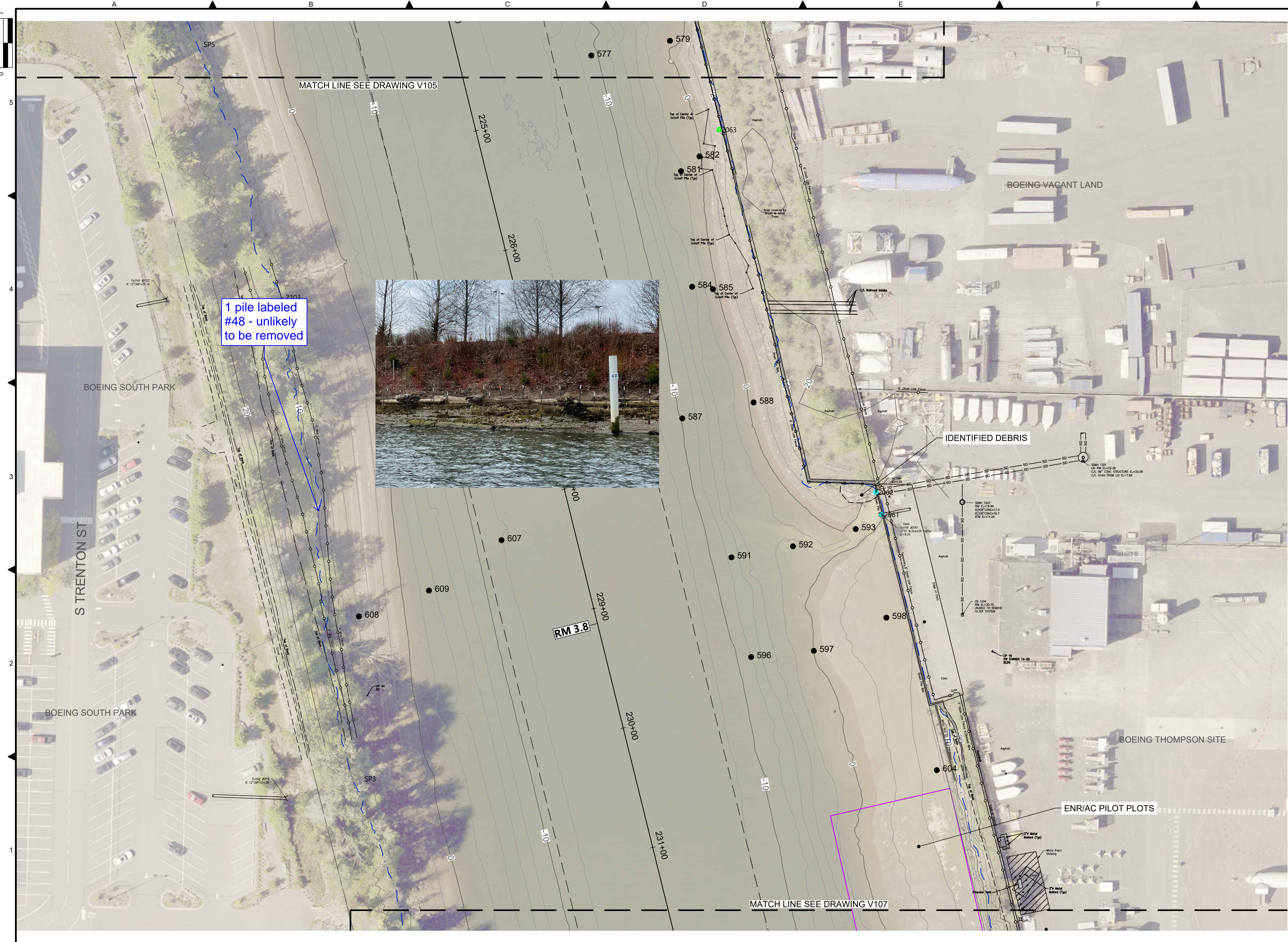

- LEGEND:**
- USACE CHANNEL CENTERLINE AND STATIONING
 - FEDERAL NAVIGATION CHANNEL
 - RM 3.0** RIVER MILE LABEL
 - KING COUNTY PARCEL (GIS)
 - LDW UPPER REACH APPROXIMATE BOUNDARY
 - EXISTING GRADE MERGED DATA SET CONTOURS (2' & 10' INTERVALS)
 - OUTFALL LOCATION (ACTIVE)
 - OUTFALL LOCATION (ABANDONED/INACTIVE)
 - OUTFALL LOCATION (REMOVED)
 - VERTICAL SAMPLE LOCATION
 - ENR/AC PILOT PLOT

- NOTES:**
1. HORIZONTAL DATUM: WASHINGTON STATE PLANE NORTH ZONE, NAD83 (2011), U.S. SURVEY FEET
 2. VERTICAL DATUM: MLLW
 3. AERIAL SOURCE: KING COUNTY 2019

COLOR IMAGE
 THIS DRAWING IS COMPOSED USING COLOR IMAGES OR PHOTOGRAPHS AND MUST BE PLOTTED, PRINTED, AND REPRODUCED IN COLOR TO BE VIEWED ACCURATELY.

NO	REVISION DESCRIPTION	BY	APVD	DATE

Lower Duwamish Waterway Group
 Port of Seattle / City of Seattle / King County / The Boeing Company

INTERMEDIATE ISSUE DRAWING
 INFORMATION ONLY
60% REVIEW
 FEBRUARY 2023

DESIGNED/DRAWN: K. GROSS	CHECKED: BIGSBY/GRIGA
PROJECT ENGINEER: J. LAPLANTE	SCALE: AS NOTED
DESIGN APPROVAL: T. WANG	PROJECT FILE NO: E00559E18
PROJECT ACCEPTANCE: PRJCT MNGR	CONTRACT NO: C0XXXXCX

DEPARTMENT OF NATURAL RESOURCES & PARKS
 WASTEWATER TREATMENT DIVISION
 LOWER DUWAMISH WATERWAY UPPER REACH
 ENGINEERING SERVICES AND SEDIMENT CLEANUP

EXISTING CONDITIONS
 (RM 3.73 TO 3.84)

DATE: FEBRUARY 2023
DRAWING NO: V106
SHT NO / TOTAL 10 / 73
REV NO: 0

BORDER FILE EDITION: x:\KOV\TD-size-TB-Border_ACBM_Layer_V\gial\CAD\Projects\0067-King County\LDW Upper Reach Engineering Services\Construction Plans\0067-LDWUR-PL-Existing Conditions.dwg | Layout: V107
 PLOTTED: Feb 20, 2023-12:39:57am By tgriga

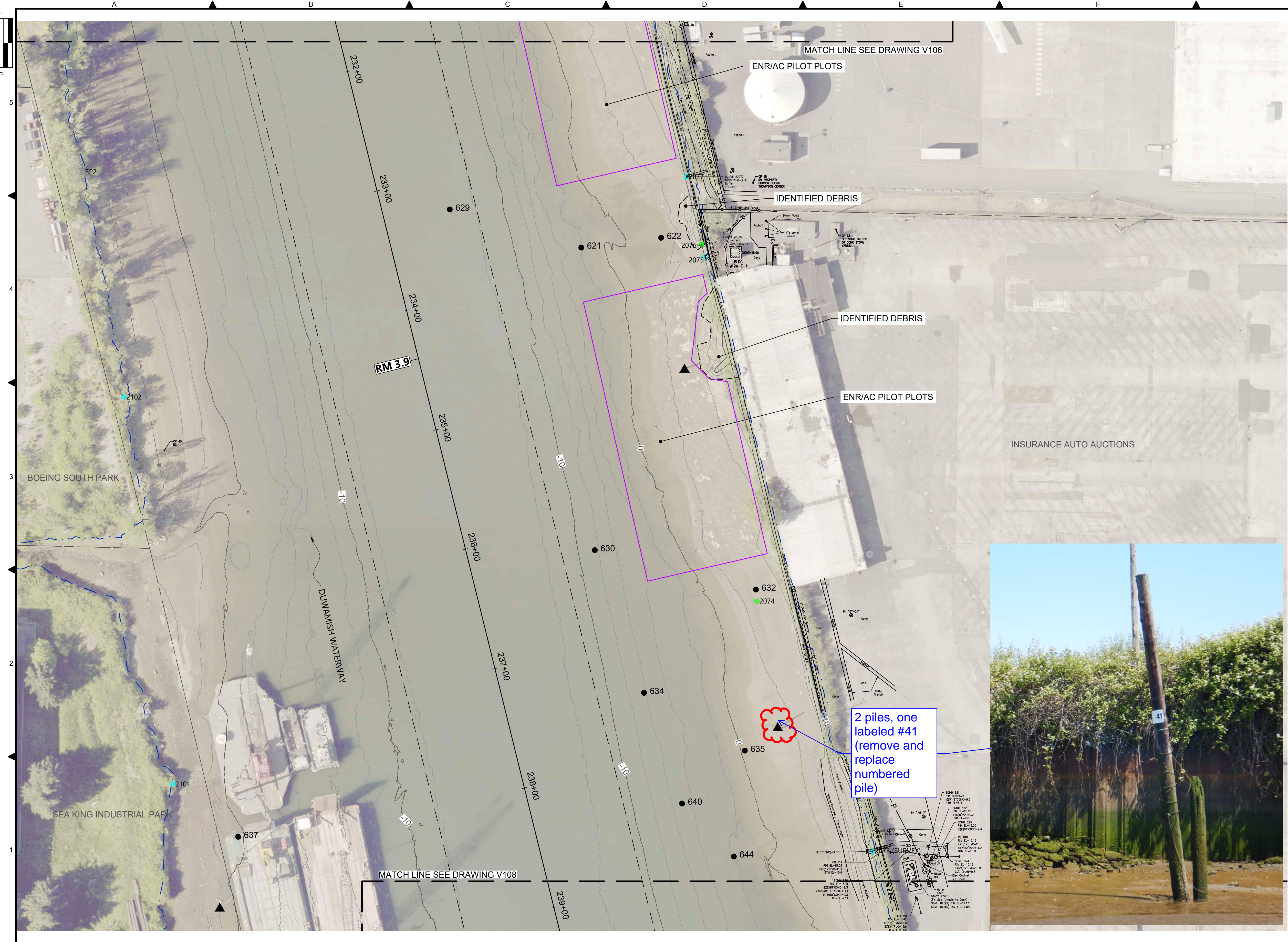

- LEGEND:**
- USACE CHANNEL CENTERLINE AND STATIONING
 - FEDERAL NAVIGATION CHANNEL
 - RM 3.0** RIVER MILE LABEL
 - KING COUNTY PARCEL (GIS)
 - LDW UPPER REACH APPROXIMATE BOUNDARY
 - EXISTING GRADE MERGED DATA SET CONTOURS (2' & 10' INTERVALS)
 - OUTFALL LOCATION (ACTIVE)
 - OUTFALL LOCATION (ABANDONED/INACTIVE)
 - OUTFALL LOCATION (REMOVED)
 - VERTICAL SAMPLE LOCATION
 - DOLPHINS
 - ENR/AC PILOT PLOT

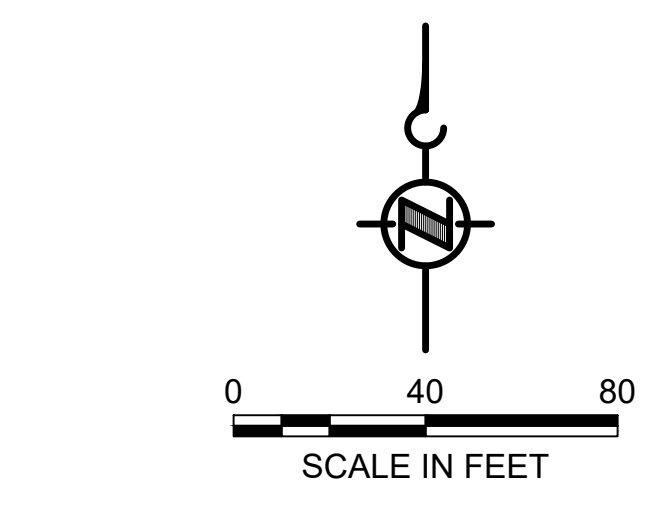
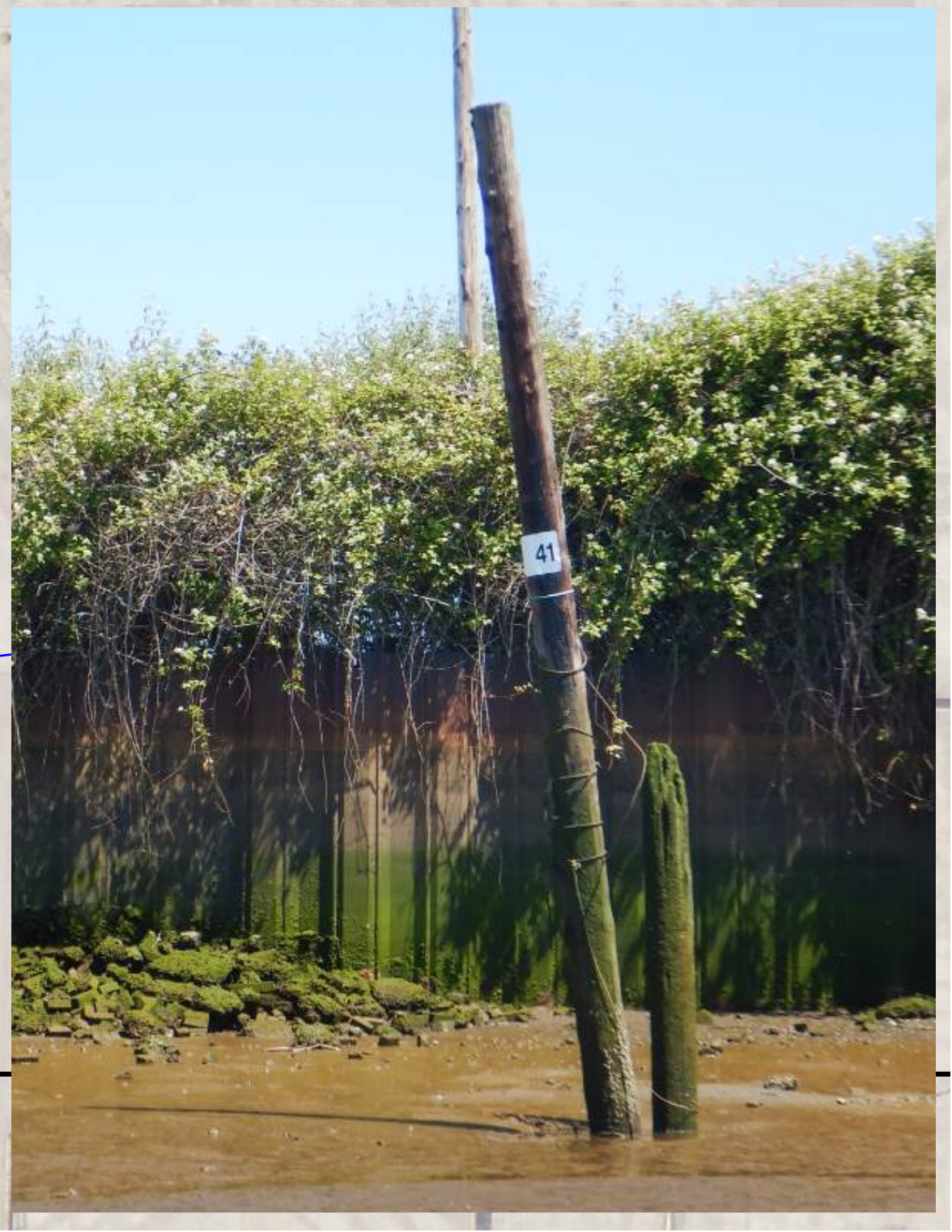

- NOTES:**
1. HORIZONTAL DATUM: WASHINGTON STATE PLANE NORTH ZONE, NAD83 (2011), U.S. SURVEY FEET
 2. VERTICAL DATUM: MLLW
 3. AERIAL SOURCE: KING COUNTY 2019

COLOR IMAGE
 THIS DRAWING IS COMPOSED USING COLOR IMAGES OR PHOTOGRAPHS AND MUST BE PLOTTED, PRINTED, AND REPRODUCED IN COLOR TO BE VIEWED ACCURATELY.

NO	REVISION DESCRIPTION	BY	APVD	DATE

Lower Duwamish Waterway Group
 Port of Seattle / City of Seattle / King County / The Boeing Company

ANCHOR QEA

INTERMEDIATE ISSUE DRAWING
 INFORMATION ONLY

60% REVIEW

FEBRUARY 2023

DESIGNED/DRAWN: K. GROSS	CHECKED: BIGSBY/GRIGA
PROJECT ENGINEER: J. LAPLANTE	SCALE: AS NOTED
DESIGN APPROVAL: T. WANG	PROJECT FILE NO: E00559E18
PROJECT ACCEPTANCE: PRJCT MNGR	CONTRACT NO: C0XXXXCXX



DEPARTMENT OF NATURAL RESOURCES & PARKS
 WASTEWATER TREATMENT DIVISION
 LOWER DUWAMISH WATERWAY UPPER REACH
 ENGINEERING SERVICES AND SEDIMENT CLEANUP

EXISTING CONDITIONS
 (RM 3.85 TO 3.99)

DATE: FEBRUARY 2023
DRAWING NO: V107
SHT NO / TOTAL 11 / 73
REV NO: 0

BORDER FILE EDITION: x:\KOVTD\size-TB-Border_ACBM\layer
 \gial\CAD\Projects\0067-King County\LDW Upper Reach Engineering Services\Construction Plans\0067-LDWUR-PL-Existing Conditions.dwg | Layout: V108
 PLOTTED: Feb 20, 2023 12:40:43am By tgriga

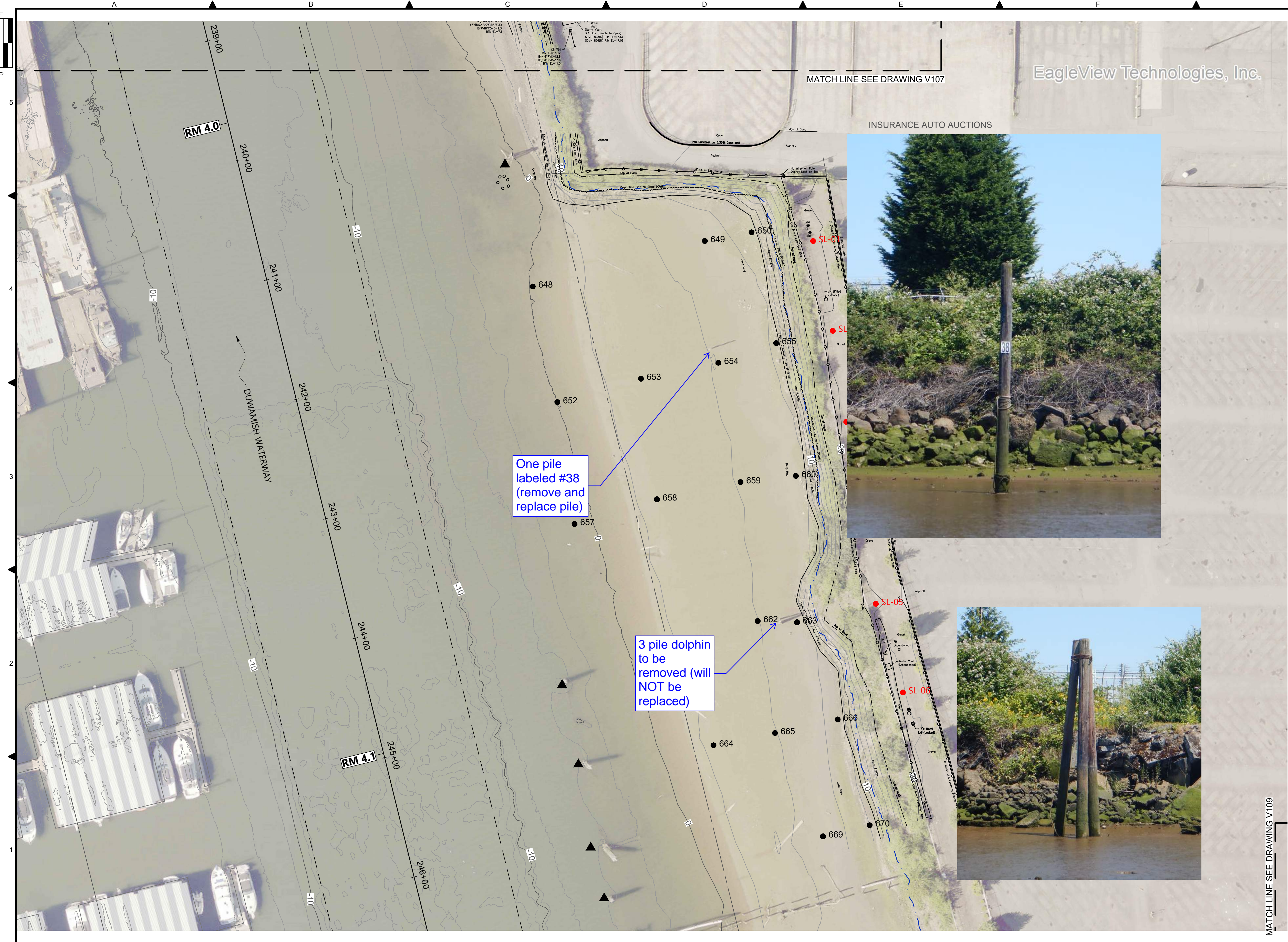

EagleView Technologies, Inc.

MATCH LINE SEE DRAWING V107

INSURANCE AUTO AUCTIONS

- LEGEND:**
- USACE CHANNEL CENTERLINE AND STATIONING
 - FEDERAL NAVIGATION CHANNEL
 - RM 3.0** RIVER MILE LABEL
 - KING COUNTY PARCEL (GIS)
 - LDW UPPER REACH APPROXIMATE BOUNDARY
 - EXISTING GRADE MERGED DATA SET CONTOURS (2' & 10' INTERVALS)
 - OUTFALL LOCATION (ACTIVE)
 - OUTFALL LOCATION (ABANDONED/INACTIVE)
 - OUTFALL LOCATION (REMOVED)
 - VERTICAL SAMPLE LOCATION
 - DOLPHINS
 - PILES
 - UPLAND SAMPLE LOCATIONS

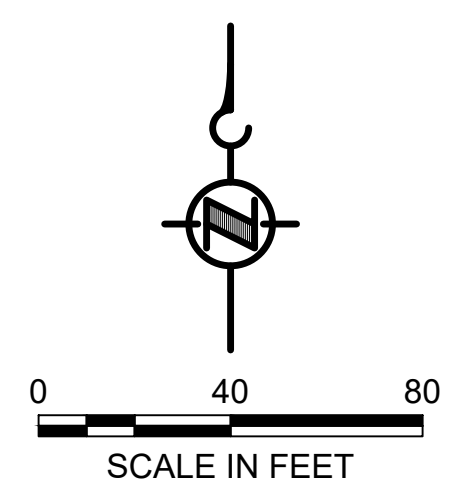

- NOTES:**
- HORIZONTAL DATUM: WASHINGTON STATE PLANE NORTH ZONE, NAD83 (2011), U.S. SURVEY FEET
 - VERTICAL DATUM: MLLW
 - AERIAL SOURCE: KING COUNTY 2019

COLOR IMAGE
 THIS DRAWING IS COMPOSED USING COLOR IMAGES OR PHOTOGRAPHS AND MUST BE PLOTTED, PRINTED, AND REPRODUCED IN COLOR TO BE VIEWED ACCURATELY.

NO	REVISION DESCRIPTION	BY	APVD	DATE

Lower Duwamish Waterway Group
 Port of Seattle / City of Seattle / King County / The Boeing Company

INTERMEDIATE ISSUE DRAWING
 INFORMATION ONLY
60% REVIEW
 FEBRUARY 2023

DESIGNED/DRAWN: K. GROSS
 PROJECT ENGINEER: J. LAPLANTE
 DESIGN APPROVAL: T. WANG
 PROJECT ACCEPTANCE: PRJCT MNGR

CHECKED: BIGSBY/GRIGA
 SCALE: AS NOTED
 PROJECT FILE NO: E00559E18
 CONTRACT NO: C0XXXXCX



DEPARTMENT OF NATURAL RESOURCES & PARKS
 WASTEWATER TREATMENT DIVISION
 LOWER DUWAMISH WATERWAY UPPER REACH
 ENGINEERING SERVICES AND SEDIMENT CLEANUP

EXISTING CONDITIONS
 (RM 3.98 TO 4.13)

DATE: FEBRUARY 2023
 DRAWING NO: **V108**
 SHT NO / TOTAL: 12 / 73
 REV NO: **0**

BORDER FILE EDITION: \\KOV\TD\size-TB-Border_AQB\Layer
 \gala\CAD\Projects\0067-King County\LDW Upper Reach Engineering Services\Construction Plans\0067-LDWUR-PL-Existing Conditions.dwg | Layout: V111
 PLOTTED: Feb 20, 2023 12:42:56am By Igriga



9 piles to be removed (will NOT be replaced)

- LEGEND:**
- USACE CHANNEL CENTERLINE AND STATIONING
 - FEDERAL NAVIGATION CHANNEL
 - RM 3.0** RIVER MILE LABEL
 - KING COUNTY PARCEL (GIS)
 - LDW UPPER REACH APPROXIMATE BOUNDARY
 - EXISTING GRADE MERGED DATA SET CONTOURS (2' & 10' INTERVALS)
 - OUTFALL LOCATION (ACTIVE)
 - OUTFALL LOCATION (ABANDONED/INACTIVE)
 - OUTFALL LOCATION (REMOVED)
 - VERTICAL SAMPLE LOCATION
 - PILES

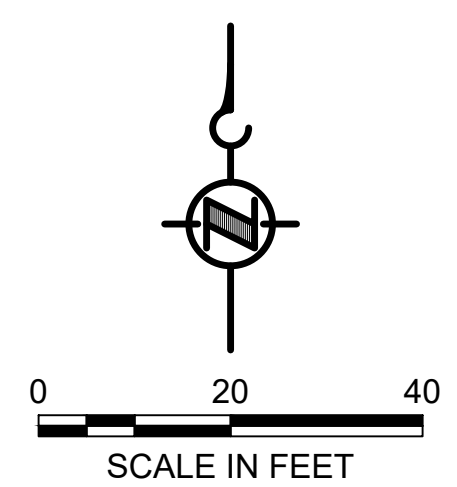

- NOTES:**
1. HORIZONTAL DATUM: WASHINGTON STATE PLANE NORTH ZONE, NAD83 (2011), U.S. SURVEY FEET
 2. VERTICAL DATUM: MLLW
 3. AERIAL SOURCE: KING COUNTY 2019

COLOR IMAGE
 THIS DRAWING IS COMPOSED USING COLOR IMAGES OR PHOTOGRAPHS AND MUST BE PLOTTED, PRINTED, AND REPRODUCED IN COLOR TO BE VIEWED ACCURATELY.

NO	REVISION DESCRIPTION	BY	APVD	DATE

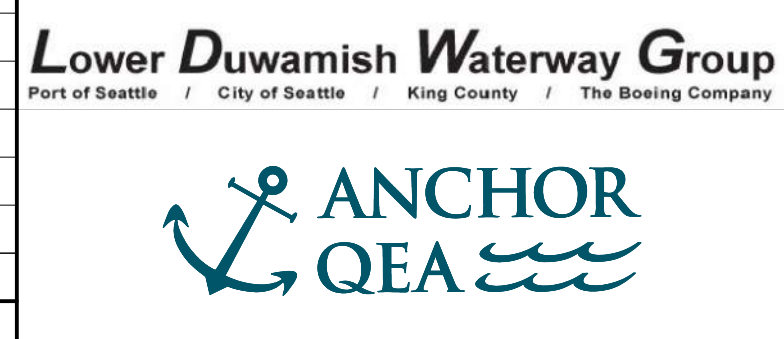

INTERMEDIATE ISSUE DRAWING
 INFORMATION ONLY
60% REVIEW
 FEBRUARY 2023

DESIGNED/DRAWN: K. GROSS
 PROJECT ENGINEER: J. LAPLANTE
 DESIGN APPROVAL: T. WANG
 PROJECT ACCEPTANCE: PRJCT MNGR

CHECKED: BIGSBY/GRIGA
 SCALE: AS NOTED
 PROJECT FILE NO: E00559E18
 CONTRACT NO: C0XXXXCX



DEPARTMENT OF NATURAL RESOURCES & PARKS
 WASTEWATER TREATMENT DIVISION
 LOWER DUWAMISH WATERWAY UPPER REACH
 ENGINEERING SERVICES AND SEDIMENT CLEANUP

EXISTING CONDITIONS
 (RM 4.64 TO 4.76)

DATE: FEBRUARY 2023
 DRAWING NO: **V111**
 SHT NO / TOTAL: 15 / 73
 REV NO: **0**

BORDER FILE EDITION: x:\KOVTD\size-TB-Border_AQB\Layer
 \gial\CAD\Projects\0067-King County\LDW Upper Reach Engineering Services\Construction Plans\0067-LDWUR-PL-Existing Conditions.dwg | Layout: V112
 PLOTTED: Feb 20, 2023 12:43:39am By tgriga

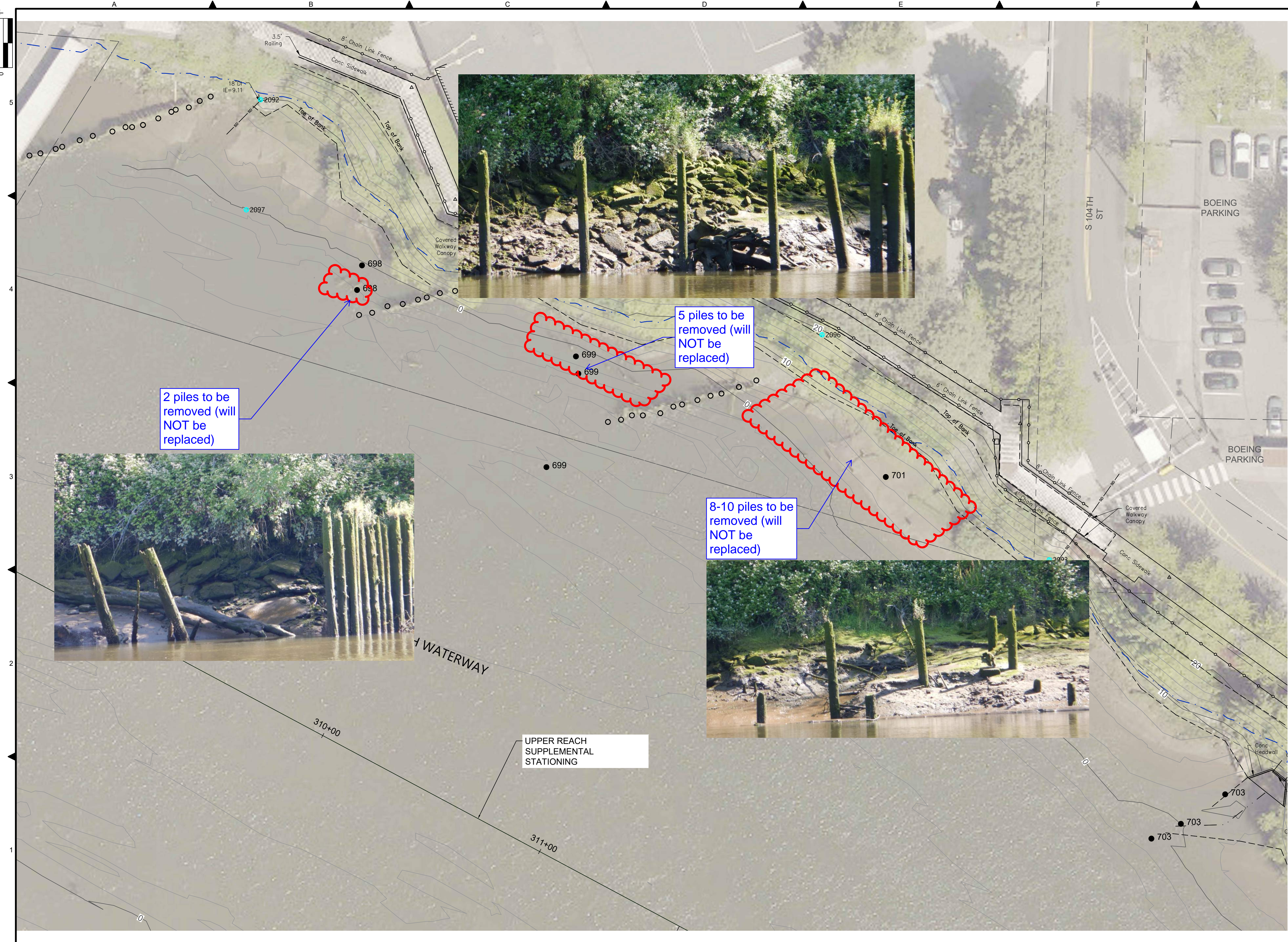

- LEGEND:**
- USACE CHANNEL CENTERLINE AND STATIONING
 - FEDERAL NAVIGATION CHANNEL
 - RM 3.0** RIVER MILE LABEL
 - KING COUNTY PARCEL (GIS)
 - LDW UPPER REACH APPROXIMATE BOUNDARY
 - EXISTING GRADE MERGED DATA SET CONTOURS (2' & 10' INTERVALS)
 - OUTFALL LOCATION (ACTIVE)
 - OUTFALL LOCATION (ABANDONED/INACTIVE)
 - OUTFALL LOCATION (REMOVED)
 - VERTICAL SAMPLE LOCATION
 - PILES

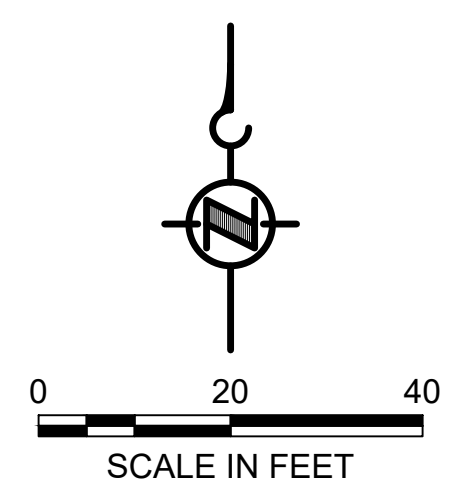

- NOTES:**
1. HORIZONTAL DATUM: WASHINGTON STATE PLANE NORTH ZONE, NAD83 (2011), U.S. SURVEY FEET
 2. VERTICAL DATUM: MLLW
 3. AERIAL SOURCE: KING COUNTY 2019

COLOR IMAGE
 THIS DRAWING IS COMPOSED USING COLOR IMAGES OR PHOTOGRAPHS AND MUST BE PLOTTED, PRINTED, AND REPRODUCED IN COLOR TO BE VIEWED ACCURATELY.

NO	REVISION DESCRIPTION	BY	APVD	DATE

Lower Duwamish Waterway Group
 Port of Seattle / City of Seattle / King County / The Boeing Company

INTERMEDIATE ISSUE DRAWING
 INFORMATION ONLY
60% REVIEW
 FEBRUARY 2023

DESIGNED/DRAWN: K. GROSS	CHECKED: BIGSBY/GRIGA
PROJECT ENGINEER: J. LAPLANTE	SCALE: AS NOTED
DESIGN APPROVAL: T. WANG	PROJECT FILE NO: E00559E18
PROJECT ACCEPTANCE: PRJCT MNGR	CONTRACT NO: C0XXXXCXX



DEPARTMENT OF NATURAL RESOURCES & PARKS
 WASTEWATER TREATMENT DIVISION
 LOWER DUWAMISH WATERWAY UPPER REACH
 ENGINEERING SERVICES AND SEDIMENT CLEANUP

EXISTING CONDITIONS
 (RM 4.84 TO 4.95)

DATE: FEBRUARY 2023
DRAWING NO: V112
SHT NO / TOTAL 16 / 73
REV NO: 0

Attachment E.7

Summary of Effects Table

**Table E.7-1
Summary of Effects of the Proposed Action**

Action Component ¹	Where	Exposure						Avoidance and Minimization Measures	Anticipated Effects of the Action
		Stressor ²	When	Duration	Frequency	Species and Life History Form	Potential Response to Stressor		
Dredging or land-based excavation (in the wet) of contaminated sediments (includes a contingency area to account for the potential that the RAA boundaries may be revised based on new Phase III PDI data)	LDW; approximately 15.2 acres total that include 0.3 acre riparian (higher than 11.3 feet MLLW), 4.9 acres intertidal (-4 to +13 feet MLLW), 1.5 acres shallow subtidal (-10 to -14 feet MLLW), and 8.5 acres deep subtidal (deeper than -10 feet MLLW).	<p>1) Turbidity/TSS and decreased DO</p> <p>2) Toxicity (COCs in sediment, surface water, and suspended sediment)</p> <p>3) Toxicity (accidental leaks/spills from vehicles/equipment)</p> <p>4) Underwater noise and construction disturbance (vehicles/equipment)</p> <p>5) Entrainment during dredging)</p> <p>6) Modification of benthic habitat and changes to prey species</p>	1–6) In-water work window across three construction seasons; for each RAA, construction will only occur during one season.	1–5) Temporary during/after implementation; construction period over 3 years. However, construction in each RAA will only occur during one season. 6) Weeks to 1 to 2 years until benthic communities recolonize and restabilize	1–6) One or more in-water work windows over 3 years; construction will only occur during one season for each RAA	<p>1–6) Juvenile PS Chinook salmon use the action area for rearing and migration and can typically be found in the action area between February and July so are only expected to be present in low numbers during construction. PS steelhead use the action area for rearing and migration and are typically found in the action area during their seaward migration, which mostly occurs from April to mid-May, so are also only expected to be present in low numbers during construction. Coastal-PS bull trout are not common in the action area and are not expected to be present during construction.</p> <p>1–6) Adult PS Chinook salmon are expected to migrate through the action area in June through early November, and PS steelhead are expected to migrate through the action area in December through April. Therefore, adult PS Chinook Salmon and PS steelhead could be present during construction. Adult Coastal-PS bull trout are not typically found in the action area.</p> <p>2) PS-GB yelloweye rockfish, PS-GB bocaccio rockfish, SRKW, and sunflower sea star may be present near the mouth of Duwamish River and Elliott Bay during and after construction.</p>	<p>1) Potential responses include direct mortality (unlikely) or sublethal impacts related to gill tissue damage from suspended sediment, physiological stress, and behavioral changes.</p> <p>2–3) Potential responses include direct mortality (unlikely) or reproductive effects due to bioaccumulation of COCs and compromised immune response.</p> <p>4) Construction-related noise during dredging is not expected to be above ambient noise levels. Disturbance due to equipment placement could lead to behavioral changes to avoid the immediate area of construction.</p> <p>5) Injury or mortality of entrained organisms could occur during dredging, especially hydraulic dredging. However, dredging is largely expected to be completed using mechanical dredging methods, which have a low potential of entraining fish.</p> <p>6) Potential responses include modification of benthic habitat affecting prey availability; temporary reduction in benthic prey base in up to approximately 5.1 acres per year (15.2 acres total).</p>	<p>1–5) Conduct all in-water work within the approved in-water work window when juvenile Chinook salmon, steelhead, and bull trout are not expected to be present or are expected only in low numbers.</p> <p>1–6) Implement general measures to minimize impacts (e.g., follow specific dredging procedures). See Section 2.4.2 for additional details and impact minimization measures.</p> <p>1–5) Employ mechanical controls (e.g., use of environmental bucket) and operational measures (e.g., avoid overfilling bucket, reduce dredging speed) to minimize sediment disturbance and dispersion. See Section 2.4.2 for additional details and minimization measures.</p> <p>1–2) Employ treatment of barge return water (e.g., filter or other treatment system of all water prior to discharge to remove suspended solids) when necessary based on water quality criteria.</p> <p>3) Adhere to emergency spill response measures according to contractor's spill containment and control plan.</p> <p>1) Perform monitoring of water quality standard parameters (e.g., turbidity, DO, pH, and temperature) in accordance with EPA-approved water quality monitoring plan during in-water work.</p> <p>2) Perform water quality monitoring of project-specific COCs in accordance with EPA-approved water quality monitoring plan during in-water work.</p> <p>6) Place suitable habitat material to return the post-dredge elevation to existing grade in all dredge areas at or shallower than -10 feet MLLW.</p> <p>6) Cover all dredge leave surfaces in waters deeper than -10 feet MLLW with a 6- to 12-inch RMC, which is expected to consist of medium to coarse sand.</p>	<p>Measures will be implemented to avoid and minimize effects to the extent possible; however, adverse effects to listed species are possible. Of all proposed activities, dredging and land-based excavation in the wet when the tide is high are anticipated to result in the most significant, farthest-reaching effects and has the highest potential to result in adverse effects.</p> <p>1) Direct salmonid mortality is considered unlikely at expected levels of turbidity/TSS. Sublethal physical, behavioral, and/or physiological effects could occur in turbidity/TSS plume. Effects of decreased DO are expected to be limited and highly localized. Additionally, work will occur when juvenile Chinook salmon, steelhead, and bull trout are not expected to be present or are expected only in low numbers.</p> <p>2) Direct salmonid mortality due to acute exposure is considered unlikely but could occur; juveniles would be more susceptible. Additionally, work will occur when juvenile Chinook salmon, steelhead, and bull trout are not expected to be present or are expected only in low numbers. Longer-term effects from COC bioaccumulation may occur. Direct rockfish, SRKW, and sunflower sea star exposure is considered unlikely, and there is minimal risk to long-term effects from COC bioaccumulation due to their distance from the dredge areas.</p> <p>3) Potential for effects is considered to be low based on impact avoidance, minimization, and conservation measures described in Section 2.4.</p> <p>4) Potential for effects is considered to be low based on work timing and ambient noise conditions in the action area.</p> <p>5) Potential for effects is considered to be low for mechanical dredging methods because pressure waves created as the bucket descends through the water column will forewarn individual fish within the area and allow them time to avoid the equipment. In the unlikely event that hydraulic dredging equipment is used for dredging, the risk of entrainment is expected to be low based on impact avoidance, minimization, and conservation measures described in Section 2.4.</p> <p>6) Anticipated effects include short-term loss of existing chemically impacted benthic foraging areas while the benthic community re-establishes and a long-term benefit of improved benthic habitat function from removal of contaminants. Recovery anticipated to occur within 1 to 2 years of dredging.</p>

Action Component ¹	Where	Exposure						Avoidance and Minimization Measures	Anticipated Effects of the Action
		Stressor ²	When	Duration	Frequency	Species and Life History Form	Potential Response to Stressor		
Placement of prospective engineered capping, backfill, and RMC within the dredge footprint (includes a contingency to account for the potential that the RAA boundaries may be revised based on new Phase III PDI data)	Prospective engineered capping after dredging: LDW; 0.4 acre of RAA 27 that includes 0.3 acre riparian and 0.1 acre intertidal, 1.0 acre over RAA 14/15/16 that is deep subtidal, plus 0.22 acre of contingency in shallow subtidal zone. Backfill after dredging (to existing grade): LDW in dredge areas that are currently -10 feet MLLW and shallower, over up to 7.7 acres. RMC (placement of a 6- to 12-inch sand layer after dredging): LDW, up to 5.9 acres total within the dredged footprint.	1) Turbidity/TSS and decreased DO 2) Toxicity (COCs in sediment, surface water, and suspended sediment) 3) Toxicity (accidental leaks/spills from vehicles/equipment) 4) Underwater noise and construction disturbance (vehicles/equipment) 5) Entrainment during cover placement 6) Modification of benthic habitat and changes to prey species	1-6) In-water work window across three construction seasons; for each RAA, construction will only occur during one season.	1-5) Temporary during/after implementation; construction period over 3 years. However, construction in each RAA will only occur during one season. 6) Weeks to 1 to 2 years until benthic communities recolonize and restabilize.	1-6) One or more in-water work windows over 3 years; construction will only occur during one season for each RAA.	1-6) Juvenile PS Chinook salmon use the action area for rearing and migration and can typically be found in the action area between February and July so are only expected to be present in low numbers during construction. PS steelhead use the action area for rearing and migration and are typically found in the action area during their seaward migration, which mostly occurs from April to mid-May, so are also only expected to be present in low numbers during construction. Coastal-PS bull trout are not common in the action area and are not expected to be present during construction. 1-6) Adult PS Chinook salmon are expected to migrate through the action area in June through early November, and PS steelhead are expected to migrate through the action area in December through April. Therefore, adult PS Chinook salmon and PS steelhead could be present during construction. Adult coastal-PS bull trout are not typically found in the action area. 2) PS-GB yelloweye rockfish, PS-GB bocaccio rockfish, SRKW, and sunflower sea star may be present near the mouth of Duwamish River and Elliott Bay during and after construction.	1) Potential responses include direct mortality or sublethal impacts related to gill tissue damage from suspended sediments, physiological stress, and behavioral changes. 2-3) Direct mortality or reproductive effects due to bioaccumulation of COCs and compromised immune response could occur but are unlikely given material placement methods. 4) Construction-related noise during material placement is not expected to be above ambient noise levels. Disturbance due to equipment placement could lead to behavioral changes to avoid the immediate area of construction. 5) Injury or mortality of entrained organisms is not likely to occur during material placement because material placement methods (using a clamshell bucket, skip box, or telebelt) have a very low potential of entraining fish as the bucket or skip box is opening or open in the water and not closing (as with dredging). In some instances, the material may be placed by opening the bucket above the water line. A telebelt is not operated within the water, so there is no chance of entrainment using this method. 6) Potential responses include modification of benthic habitat affecting prey availability and temporary reduction in benthic prey base in the same footprint as dredging (i.e., not a new area of impact).	1-5) Conduct all in-water work within the approved in-water work window when juvenile Chinook salmon, steelhead, and bull trout are not expected to be present or are expected only in low numbers. 1-6) Implement general impact minimization measures that allow import materials to be placed in a controlled and accurate manner and that limit disturbance of the bottom sediments (e.g., follow an engineered cap placement sequencing strategy, follow appropriate material placement methods to achieve uniform coverage). See Section 2.4.5 for additional details and impact minimization measures. 1-5) Employ operational BMPs (e.g., work from lower to higher elevations during placement) to minimize sediment disturbance and dispersion. See Section 2.4.5 for additional details. 1) Perform monitoring of water quality standard parameters (turbidity, DO, temperature, and pH) in accordance with EPA-approved water quality monitoring plan during in-water work. 1-2) Imported materials must be approved before use; therefore, testing of the borrow source material will be required of the contractor to demonstrate that the source material meets chemical and physical criteria. 2) Place cap or cover layer as soon as possible after dredging to minimize recontamination risk from contaminants. 1-2) Imported materials should consist of clean, granular material free of roots, organic material, contaminants, and all other deleterious material. 3) Adhere to emergency spill response measures according to contractor's spill containment and control plan. 6) Dredging will occur prior to prospective engineered capping or backfill placement in areas with an existing elevation of -10 feet MLLW or shallower to allow for net zero bathymetry change. 6) Place a sand and gravel habitat layer (e.g., fish/habitat mix) on top of the cap armor layer and as backfill in areas at elevation -10 feet MLLW or shallower, unless existing condition is a steep armored slope, to enhance substrate for benthic invertebrates, which are prey for juvenile salmonids. The habitat material will also fill in the interstitial spaces between the cap armor, which will remove potential hiding places for salmonid predators. 6) Place RMC (sand layer) within the dredge prism to manage dredge residuals.	Measures will be implemented to avoid and minimize effects to the extent possible; however, adverse effects to listed species are possible. 1) Direct salmonid and bull trout mortality is considered unlikely at expected levels of TSS. Sublethal physical, behavioral, and/or physiological effects could occur in turbidity/TSS plume. Effects of decreased DO are expected to be limited and highly localized. Additionally, work will occur when juvenile Chinook salmon, steelhead, and bull trout are not expected to be present or are expected only in low numbers. 2) Direct salmonid and bull trout mortality due to acute exposure to contaminants is considered unlikely to occur during placement of prospective engineered capping, backfill, and RMC materials given that the placement methods used are intended to minimize the potential for contaminated sediment resuspension. Additionally, work will occur when juvenile Chinook salmon, steelhead, and bull trout are not expected to be present or are expected only in low numbers. Longer-term effects from COC bioaccumulation are also unlikely to occur with this activity. Direct rockfish, SRKW, and sunflower sea star exposure is considered extremely unlikely due to their distance from the construction activity and there is very minimal risk to long-term effects from COC bioaccumulation resulting from placing prospective engineered capping, backfill, and RMC materials. 3) Potential for effects is considered to be low based on impact avoidance, minimization, and conservation measures described in Section 2.4. 4) Potential for effects is considered to be low based on work timing and ambient noise conditions in the action area. 5) Entrainment is not expected to occur during material placement because of the material placement methods that consist of the bucket or skipbox opening or being open in the water and not closing (as with dredging), or a telebelt that is operated on land and not in the water. 6) Recovery of benthic invertebrates would occur within 1 to 2 years because these areas would all be dredged prior to material placement. Anticipated effects include long-term benefit of improved benthic habitat function due to placement of clean surface substrate.

Action Component ¹	Where	Exposure						Avoidance and Minimization Measures	Anticipated Effects of the Action
		Stressor ²	When	Duration	Frequency	Species and Life History Form	Potential Response to Stressor		
Placement of RMC in the inner and outer dredge perimeter, ENR, and amended cover materials (no dredging, only material placement; includes a contingency to account for the potential that the RAA boundaries may be revised based on new Phase III PDI data)	RMC (no dredging; placement of 6- to 12-inch sand layer in the inner and outer dredge perimeter): LDW, up to 12.1 acres. ENR (no dredging; placement of 6- to 12-inch sand and gravel layer): LDW over up to 0.83 acre. Amended cover (no dredging; 6- to 12-inch sand and gravel layer amended with granulated activated carbon): LDW in portions of RAAs 18, 24, and 26 over up to 0.18 acre.	1) Turbidity/TSS and decreased DO 2) Toxicity (accidental leaks/spills from vehicles/equipment) 3) Underwater noise and construction disturbance (vehicles/equipment) 4) Entrainment during cover placement 5) Modification of benthic habitat and changes to prey species	1–5) In-water work window across three construction seasons; for each RAA, construction will only occur during one season.	1–4) Temporary during/after implementation; construction period over 3 years. However, construction in each RAA will only occur during one season. 5) Weeks to 1 year until benthic communities recolonize and restabilize	1–5) One or more in-water work windows over 3 years; construction will only occur during one season for each RAA.	1–5) Juvenile PS Chinook salmon use the action area for rearing and migration and can typically be found in the action area between February and July so are only expected to be present in low numbers during construction. PS steelhead use the action area for rearing and migration and are typically found in the action area during their seaward migration, which mostly occurs from April to mid-May, so are also only expected to be present in low numbers during construction. Coastal-PS bull trout are not common in the action area and are not expected to be present during construction. 1–5) Adult PS Chinook salmon are expected to migrate through the action area in June through early November, and PS steelhead are expected to migrate through the action area in December through April. Therefore, adult PS Chinook salmon and PS steelhead could be present during construction. Adult coastal-PS bull trout are not typically found in the action area.	1) Potential responses include direct mortality or sublethal impacts related to gill tissue damage from suspended sediments, physiological stress, and behavioral changes. 2) Direct mortality due to exposure to leaked or spilled material and compromised immune response could occur but are unlikely given impact avoidance, minimization, and conservation measures to reduce potential for accidental leaks and spills from construction vehicles/equipment. Resuspension of contaminants is not expected to occur due to material placement activities in non-dredged areas. 3) Construction-related noise during material placement is not expected to be above ambient noise levels. Disturbance due to equipment placement could lead to behavioral changes to avoid the immediate area of construction. 4) Injury or mortality of entrained organisms is not likely to occur during material placement because material placement methods (using a clamshell bucket, skip box, or telebelt) have a very low potential of entraining fish as the bucket or skipbox is opening or open in the water and not closing (as with dredging). In some instances, the material may be placed by opening the bucket above the water line. A telebelt is not operated within the water, so there is no chance of entrainment using this method. 5) Modification of benthic habitat affecting prey availability; temporary reduction in benthic prey base in up to approximately 4.3 acres per year (12.9 acres total).	1–5) Conduct all in-water work within the approved in-water work window when juvenile Chinook salmon, steelhead, and bull trout are not expected to be present or are expected only in low numbers. 1–5) Implement general impact minimization measures that allow import materials to be placed in a controlled and accurate manner and that limit disturbance of the bottom sediments (e.g., follow appropriate material placement methods to achieve uniform coverage). See Section 2.4.5 for additional details and impact minimization measures. 1–4) Employ operational measures (e.g., work from lower to higher elevations during placement) to minimize sediment disturbance and dispersion. See Section 2.4.5 for additional details. 1) Perform monitoring of water quality standard parameters (turbidity, DO, temperature, and pH) in accordance with EPA-approved water quality monitoring plan during in-water work. 1) Imported materials should consist of clean, granular material free of roots, organic material, contaminants, and all other deleterious material. 1) Imported materials must be approved before use; therefore, testing of the borrow source material will be required of the contractor to demonstrate that the source material meets chemical and physical criteria. 2) Adhere to emergency spill response measures according to contractor's spill containment and control plan. 5) Place RMC (sand layer) adjacent to the dredge prism to manage dredge residuals. 5) Place ENR and Amended Cover (sand and gravel) on top of the existing substrate to accelerate natural recovery processes and to reduce the bioavailability of COCs in biologically active zone, respectively.	Measures will be implemented to avoid and minimize effects to the extent possible; however, adverse effects to listed species are possible. 1) Direct salmonid and bull trout mortality is considered unlikely at expected levels of TSS. Sublethal physical behavioral, and/or physiological effects could occur in turbidity/TSS plume. Effects of decreased DO expected to be limited and highly localized. Additionally, work will occur when juvenile Chinook salmon, steelhead, and bull trout are not expected to be present or are expected only in low numbers. 2) Potential for effects is considered to be low and insignificant based on impact avoidance, minimization, and conservation measures described in Section 2.4. 3) Potential for effects is considered to be low based on work timing and ambient noise conditions in the action area. 4) Entrainment is not expected to occur during material placement because of the material placement methods that consist of the bucket or skipbox opening or being open in the water and not closing (as with dredging), or a telebelt that is operated on land and not in the water. 5) Anticipated effects include short-term loss of existing chemically impacted benthic foraging areas while the benthic community re-establishes and a long-term benefit of improved benthic habitat function due to placement of clean surface substrate. Recovery of benthic invertebrates would occur over weeks following the placement of clean material.

Action Component ¹	Where	Exposure						Avoidance and Minimization Measures	Anticipated Effects of the Action
		Stressor ²	When	Duration	Frequency	Species and Life History Form	Potential Response to Stressor		
In-water structure modifications: pile removal and installation and outfall bank protection	Pile removal and installation: LDW, RAA 13 (remove two timber and three steel pipe piles, install five steel pipe piles) ³ , RAA 27 (remove eight timber piles/install one steel pipe pile), RAA 30/31 (remove nine timber piles), LDW in deep subtidal areas outside of the FNC (install up to ten 36-inch steel pipe piles temporarily for contractor's vessel moorage). Outfall bank protection: LDW bank, RAAs 13, 18, 26, 33/34/35 total area of 2,160 square feet (540 square feet each).	1) Turbidity/TSS and decreased DO 2) Toxicity (pile removal and accidental leaks/spills from vehicles/equipment) 3) Underwater noise and construction disturbance (vibratory pile driver) 4) Modification of benthic habitat and changes to prey species	1-4) In-water work window; for each RAA, construction will only occur during one season.	1-3) Temporary during/after implementation; construction period over 3 years. However, construction in each RAA will only occur during one season. 4) Weeks to 1 to 2 years until benthic communities recolonize and restabilize for areas where piles will be removed; permanent for areas where outfall bank protection is placed.	1-4) One or more in-water work windows over 3 years; construction will only occur during one season for each RAA.	1-4) Juvenile PS Chinook salmon use the action area for rearing and migration and can typically be found in the action area between February and July so are only expected to be present in low numbers during construction. PS steelhead use the action area for rearing and migration and are typically found in the action area during their seaward migration, which mostly occurs from April to mid-May, so are also only expected to be present in low numbers during construction. Coastal-PS bull trout are not common in the action area and are not expected to be present during construction. 1-4) Adult PS Chinook salmon are expected to migrate through the action area in June through early November, and PS steelhead are expected to migrate through the action area in December through April. Therefore, adult PS Chinook salmon and PS steelhead could be present during construction. Adult Coastal-PS bull trout are not typically found in the action area.	1) Potential responses include direct mortality or sublethal impacts related to gill tissue damage from suspended sediments, physiological stress, and behavioral changes. 2) Direct mortality or reproductive effects due to bioaccumulation of COCs and compromised immune response could occur but are unlikely given impact avoidance, minimization, and conservation measures to reduce impacts during pile removal and potential for accidental leaks and spills from construction vehicles/equipment from occurring. 3) Vibratory pile driving may generate noise above behavior and injury thresholds for salmonids at limited distances from the pile driving activity. However, only adverse behavioral effects are anticipated due to elevated underwater noise. 4) Potential responses include modification of benthic habitat affecting prey availability, temporary reduction in benthic prey base in 7.16 square feet of intertidal habitat from the permanent decrease in pile areal coverage, and permanent impact to benthic habitat affecting prey availability in 2,160 square feet of intertidal habitat from placement of outfall bank protection.	1-4) Conduct all in-water work within the approved in-water work window when juvenile Chinook salmon, steelhead, and bull trout are not expected to be present or are expected only in low numbers. 1-3) Employ physical barriers (e.g., floating containment boom), mechanical controls (e.g., vibratory method for pile removal and installation), and operational measures (e.g., slow pile removal, avoid deformation during pile removal) to minimize sediment disturbance and dispersion. See Sections 2.4.6 and 2.4.7 for additional details. 3) Use vibratory methods for pile removal and installation to minimize noise impacts.	Measures will be implemented to avoid and minimize effects to the extent possible; however, adverse effects may occur. 1) Direct salmonid and bull trout mortality is considered unlikely at expected levels of TSS. Sublethal physical behavioral, and/or physiological effects could occur in turbidity/TSS plume. Effects of decreased DO are expected to be limited and highly localized. Additionally, work will occur when juvenile Chinook salmon, steelhead, and bull trout are not expected to be present or are expected only in low numbers. 2) Direct salmonid mortality due to acute exposure is considered unlikely but could occur due to sediment disturbance during pile removal activities; juveniles would be more susceptible. Additionally, work will occur when juvenile Chinook salmon, steelhead, and bull trout are not expected to be present or are expected only in low numbers. Direct rockfish, SRKW, and sunflower sea star exposure is considered unlikely, and there is minimal risk to long-term effects from COC bioaccumulation due to their distance from the pile removal areas. Potential for effects from accidental leaks and spills is considered to be low and insignificant based on impact avoidance, minimization, and conservation measures described in Section 2.4. 3) Potential for behavioral effects to occur is considered to be low based on work timing and limited spatial extent of pile removal and installation. No injury thresholds are expected to be exceeded during pile driving activities. 4) Anticipated effects include a net gain of 7.16 square feet of intertidal habitat from the permanent decrease in pile areal coverage and impact to 2,160 square feet (0.05 acre) of intertidal habitat from placement of bank outfall protection. Overall, 2,153 square feet (0.05 acre) of existing chemically impacted benthic habitat will be impacted by in-water structure modifications.

Notes:

1. Transport and transloading of dredged material is not included in this table because potential effects associated with barge transport of contaminated sediment to an on-site or off-site transload facility and transloading material are considered de minimis as detailed in Section 2.2.2.1. Impact avoidance and minimization measures described in Section 2.4.4 of the *Biological Assessment* will further reduce the potential for impacts to occur during these activities.
2. Each stressor in this column is numbered. This number is used in the columns to the right to link each element back to a specific stressor. For example, the first avoidance and minimization measure for dredging is to conduct work within the approved in-water work window, and this measure addresses stressors 1 through 5 as indicated by the "1-5" at the beginning of the measure.
3. The pile numbers are conservative, pending changes in design related to Phase III data, which may result in fewer structure changes.

BMP: best management practice
COC: contaminant of concern
DO: dissolved oxygen
ENR: enhanced natural recovery
EPA: U.S. Environmental Protection Agency

FNC: federal navigation channel
GB: Georgia Basin
LDW: Lower Duwamish Waterway
MLLW: mean lower low water
PDI: pre-design investigation

PS: Puget Sound
RAA: remedial action area
RMC: residuals management cover
SRKW: Southern Resident killer whale
TSS: total suspended solids

90% Remedial Design Basis of Design Report

Attachment E.6.2

PNSC Workbook 1 of 2

Pugent Sound Nearshore Habitat Conservation Calculator

Summary

Blue cells contain section headings
 Rose cells contain questions that need to be answered to fill out calculator
 Grey cells contain units requested for entry
 Yellow cells indicate user entry fields
 Green cells contain additional explanations and resource links
 Maroon cells contain summary values

Action Agency Reference #	
FWS or NMFS #	
Project Name:	Lower Duwamish Waterway Upper Reach Remedial Design
Prepared on and by:	Workbook 1 of 2, 14-July 2023, Sydney Gonsalves (Anchor QEA)

Puget Sound Nearshore Habitat Conservation Calculator

Version 1.5 **2/24/2023**

This tool determines long-term habitat impacts and benefits for projects in the Salish Sea nearshore. Details about the use of this Conservation Calculator can be found in the User Guide, FAQs, and training materials, which are all available on the [Puget Sound Nearshore Habitat Conservation Calculator Webpage](#)

		Conservation Credits/Debits	DSAYs (Discounted Service Acre Years)
Overwater Structures	Debit	-1	-0.01
	Credit (includes creosote removal)	7	0.07
	Balance	5	0.05
Shoreline Armoring	Debit	0	0.00
	Credit from Armor Removal	0	0.00
	Credit from Creosote Removal	0	0.00
	Balance	0	0.00
Maintenance Dredging	Balance	0	0.00
Boatramps, Jetties, Rubble	Debit	-9	-0.09
	Credit	12	0.12
	Balance	4	0.04
Beach Nourishment	Conservation Offsets	0	0.00
Riparian Enhancement/Degradation	Balance	-35	-0.35
SAV Planting	Conservation Credit	0	0.00
Habitat Loss / Remaining Conservation Offsets Needed		-26	-0.26

Is this a standalone restoration project?*	No		
---------------------------------------------------	-----------	--	--

* Standalone restoration actions are actions that can be executed outside of a replacement or construction of new structures. They have no negative long term habitat impacts. A standalone restoration action solely restores or improves habitat functions. It does not introduce new or temporarily extend adverse effects aside from construction-related effects. Standalone restoration projects include removal of a structure (that has adverse effects) without its replacement.

Habitat Loss/Remaining Conservation Offsets Needed (Workbook 1 of 2)	-0.26
Habitat Loss/Remaining Conservation Offsets Needed (Workbook 1 of 2)	1.31
	1.05 Total

Project Details

Project Details

Include all metrics and rationale used to fill out this Calculator. Note where you found all relevant information (JARPA, BE, other).

Orange cells contain questions from NMFS for the applicant or agency.

Project Name:	Lower Duwamish Waterway Upper Reach Remedial Design		
Marine Basin:	South Central Puget Sound	Click on the Beach Slope Reference Line at the project location to find the Marine Basin Name and other information.	
Location (lat, long):	47.532268 N, 122.319532 W (Web Mercator)		
Project Description:	The Lower Duwamish Waterway Group (LDWG), in coordination with the U.S. Environmental Protection Agency (EPA) and Washington State Department of Ecology (Ecology), is implementing a cleanup remedy for the upper reach of the Lower Duwamish Waterway (LDW) Comprehensive Environmental Response, Compensation, and Liability Act (CERCLA, or Superfund) Site in King County, Washington (EPA Site No. WA00002329803). The LDW Superfund Site extends 5 miles upstream from the southern tip of Harbor Island to just upstream of the Turning Basin at river mile (RM) 5; the upper reach comprises the furthest upstream two RMs: 3.0 to 5.0.		
Elements entered in this Calculator:	Workbook 1 of 2: Riparian habitat disturbed during construction (RZ), piles removed and installed during construction (Overwater Structures), bulkhead wall replacement (InputShorl and ShorelStab), debris removal (BoatR, Jetty). Workbook 2 of 2: Riparian habitat restored after construction (RZ), shoreline armoring replacement (InputShorl and ShorelStab)		

Site Specific Factors

Enter site specific credit factors and submerged aquatic vegetation (SAV) scenarios in the yellow boxes below. They will auto-apply to all tabs. If more than one project location exists, enter each location in a separate calculator file and submit both.

	Yes or No	% Change	Applicable to:	Ref: Application of Factors
Natal Estuary	No	0%	All tabs	Ref: Application of Factors
Is the project within 5 miles of a Puget Sound Chinook natal estuary or 1 mile of a Hood Canal summer-chum natal estuary? If yes, a factor of 50% applies. A project in both natal estuary and pocket estuary/embayment receives a combined 90% factor.				
Pocket Estuary or Embayment	No	0%	All tabs	Ref: Pocket Estuaries and Embayments
Is the project located within a pocket estuary/embayment? If yes, a factor of 30% applies. If also within a natal estuary zone, a factor of 40% applies.				
Forage Fish Spawning	No	0%	USZ for all tabs	
Is there sand lance or surf smelt spawning on the project site (as mapped or determined by WDFW)? If yes, a factor of 50% applies.				
Same Drift Cell and Updrift of Forage Fish Use Coastal Atlas "Drift Cell" map Layer	No	0%	USZ for ShorelStab, BoatRJetty, Beach N	Use Coastal Atlas "Drift Cells" map layer along with WDFW Forage Fish Spawning map
Is the project within the same drift cell <i>and</i> updrift of sand lance or surf smelt spawning? If yes, a factor of 20% applies <i>if</i> there is no forage fish spawning documented.				
Herring Spawning	No	0%	LSZ and DSZ structures in all tabs except RZ	Overwater structures in DSZ herring spawning and holding areas may have herring spawning factor applied depending on size and design. See the User Guide for more information.
Does the project site have documented herring spawning (as mapped or determined by WDFW)? If yes, a factor of 50% applies.				
Feeder Bluff	No	0%	RZ, ShorelStab	Use Coastal Atlas "Coastal Landforms" map layer
Is the project located at a feeder bluff? If yes, a factor of 50% applies.				
LSZ Submerged Aquatic Vegetation (SAV) and USZ Upper Intertidal Vegetation Scenario				
Upper Shore Zone	0	Select a number 1 - 3. Vegetation scenarios should be based on the average plant density in the footprint of the structure including a 25-foot buffer around the structure.		
Lower Shore Zone	0			

Document additional project information below.

Tab: RZ Note: Tab RZ in workbook 1 of 2 shows removal of trees near RAA 27 during construction and Tab RZ in workbook 2 of 2 shows replanting of removed trees plus planting of top-of-bank native riparian vegetation.

Riparian Area to be disturbed at RAA 27, from removal of existing riprap and placement of armor cap for contaminated sediment remediation will include landscaped trees along the parking lot fence line. Non-native shrubs (Himalayan blackberry and butterfly bush) over riprap bank is not considered in pre-construction riparian conditions

Pre-Construction

Num Trees	Area (sq ft)	total area	
9	200	1800	trees along fence

Post-Construction - replanting of native shrubs (shown in Workbook 2 of 2)

Length (ft)	Width (ft)	Area (sq. ft)
270	10	2700
244	20	4880
		<u>7580 Total</u>

Pre-Construction - trees along fence line above RAA 27

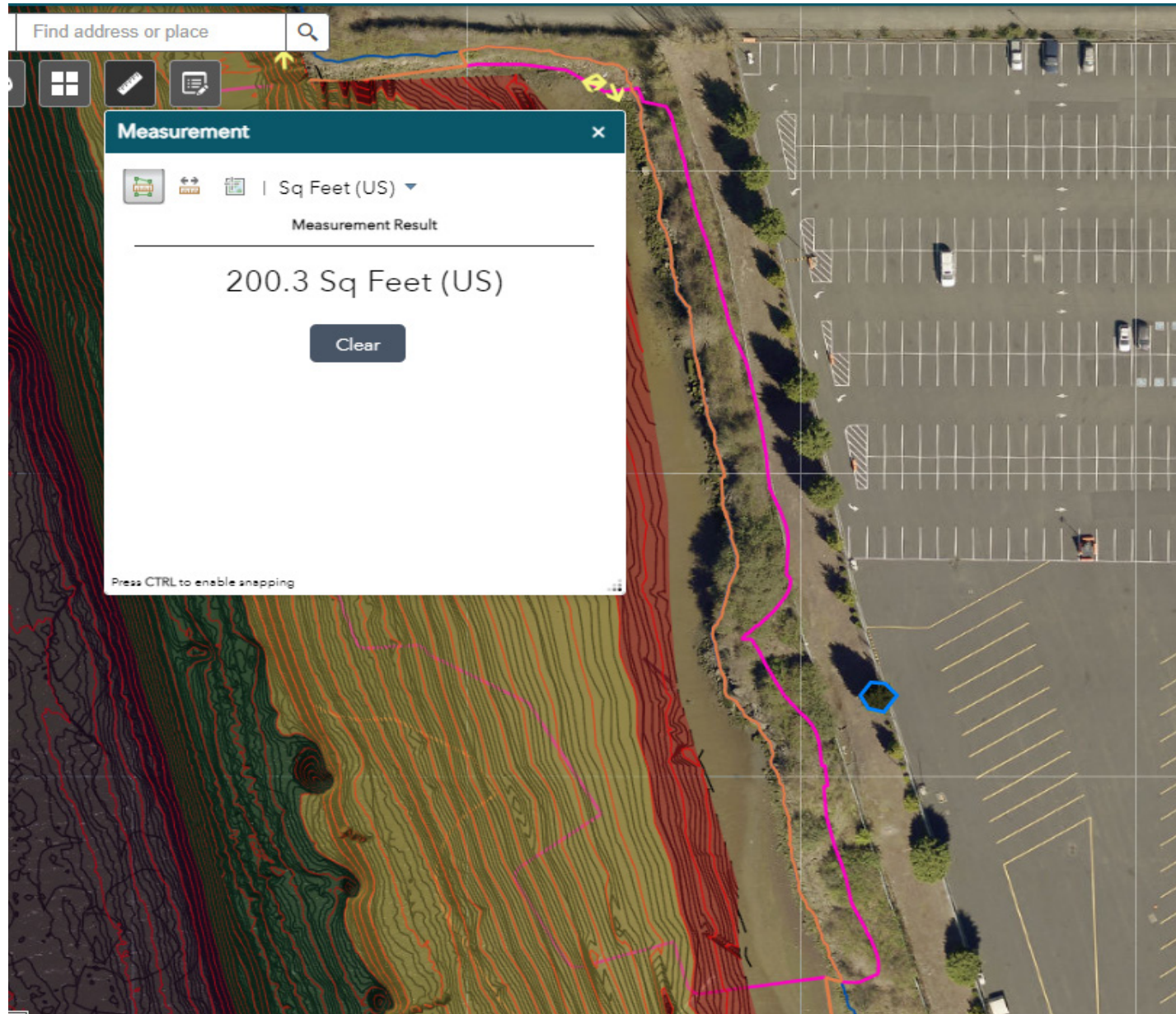

Post-Construction - cap area to be planted with native shrubby, fence line trees would also be replaced.



Tab: Overwater Structures

Project Piles to be removed and installed

RAA	Habitat Zone	Number	Dia. (in)	Est. Length (Material)	Creosote?	Replace?	Rep Mat.	Rep Dia. (in)	No. Rep.
24/25, 26	LSZ	2	10	10 timber	yes	yes	steel	14	1
	27 LSZ	3	10	10 timber	yes	no			
	27 LSZ	1	10	10 timber	yes	yes	steel	14	1
30/31	USZ	9	10	10 timber	yes	no			
	32 LSZ	2	10	10 timber	no	no			
33/34/35	LSZ	5	10	10 timber	no	no			
33/34/35	USZ	8	10	10 timber	no	no			
	Total	30						Total	2

Tab: BoatR, Jetty

RAA	Toe Elev (ft MLLW)	Toe Elev (ft)	Length Rem	Length Insta	Offset (ft) from existing	Riparian conditions after construction		
						length(ft)	width(ft)	area(sq ft)
22	10	7.6	160	160	1.5	160	130	20800 sand, gravel, impervious

Note: the reinforcing bulkhead will be installed approximately 1.5 feet horizontal distance in front of (water-ward of) the existing bulkhead
 Space between old and new bulkhead walls will be filled. Construction is expected to occur from the water. Top of bulkhead wall shrubs are non-native and not included on RZ tab.



Tab: BoatR, Jetty

Debris pile removal in RAAs 18 and 22

RAA	Area (sq ft)
18	404.8
22	512.5
22	1346.8
<hr/>	
	1859.3 Total area of debris removal

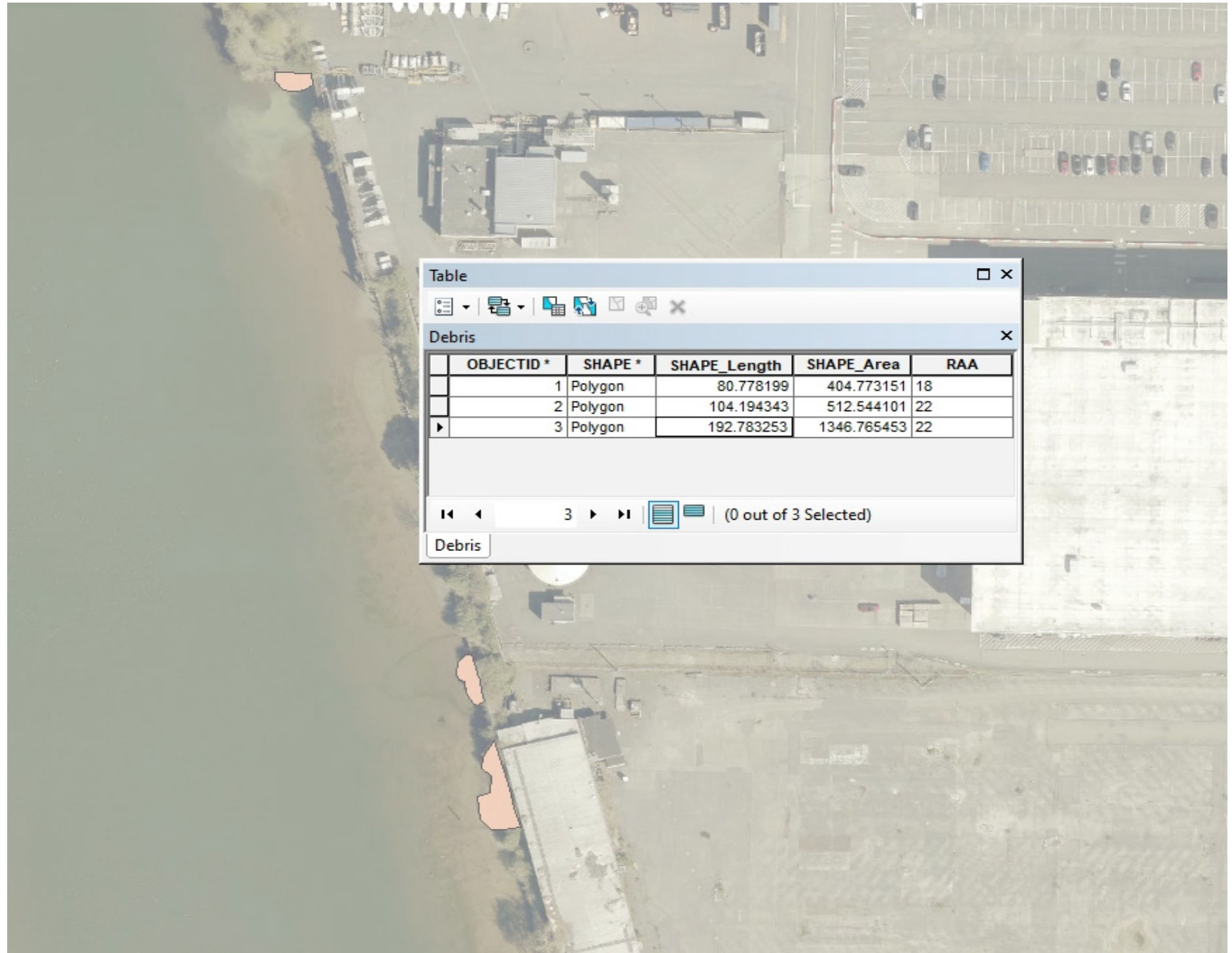

Site Specific Factors

Mapping Screen Shots of Project Area (Upper Reach of the Lower Duwamish River)

Natal Estuary

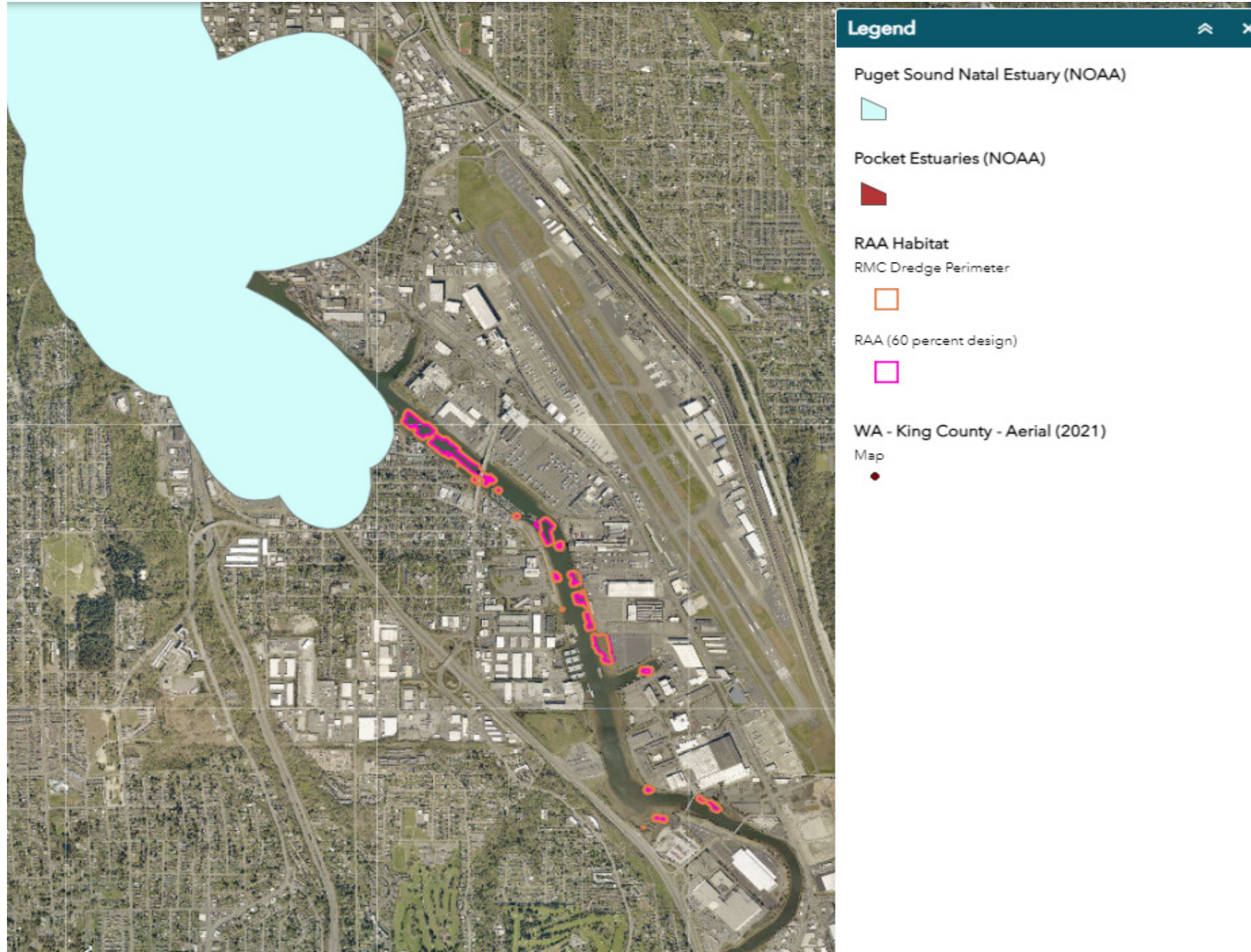

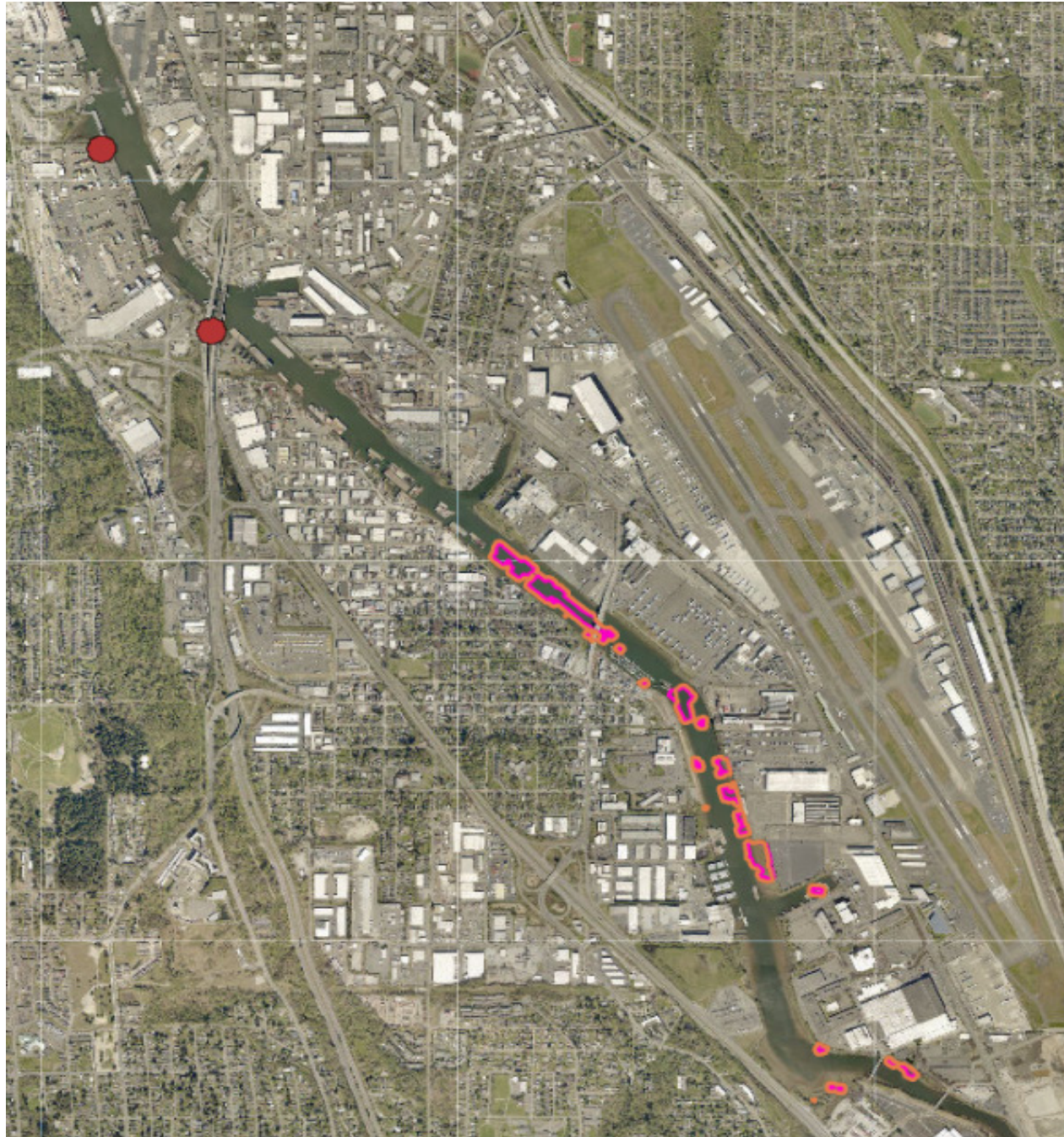

Legend ⤴ ✕

Pocket Estuaries (NOAA)

RAA Habitat

RMC Dredge Perimeter

RAA (60 percent design)

WA - King County - Aerial (2021)

Map

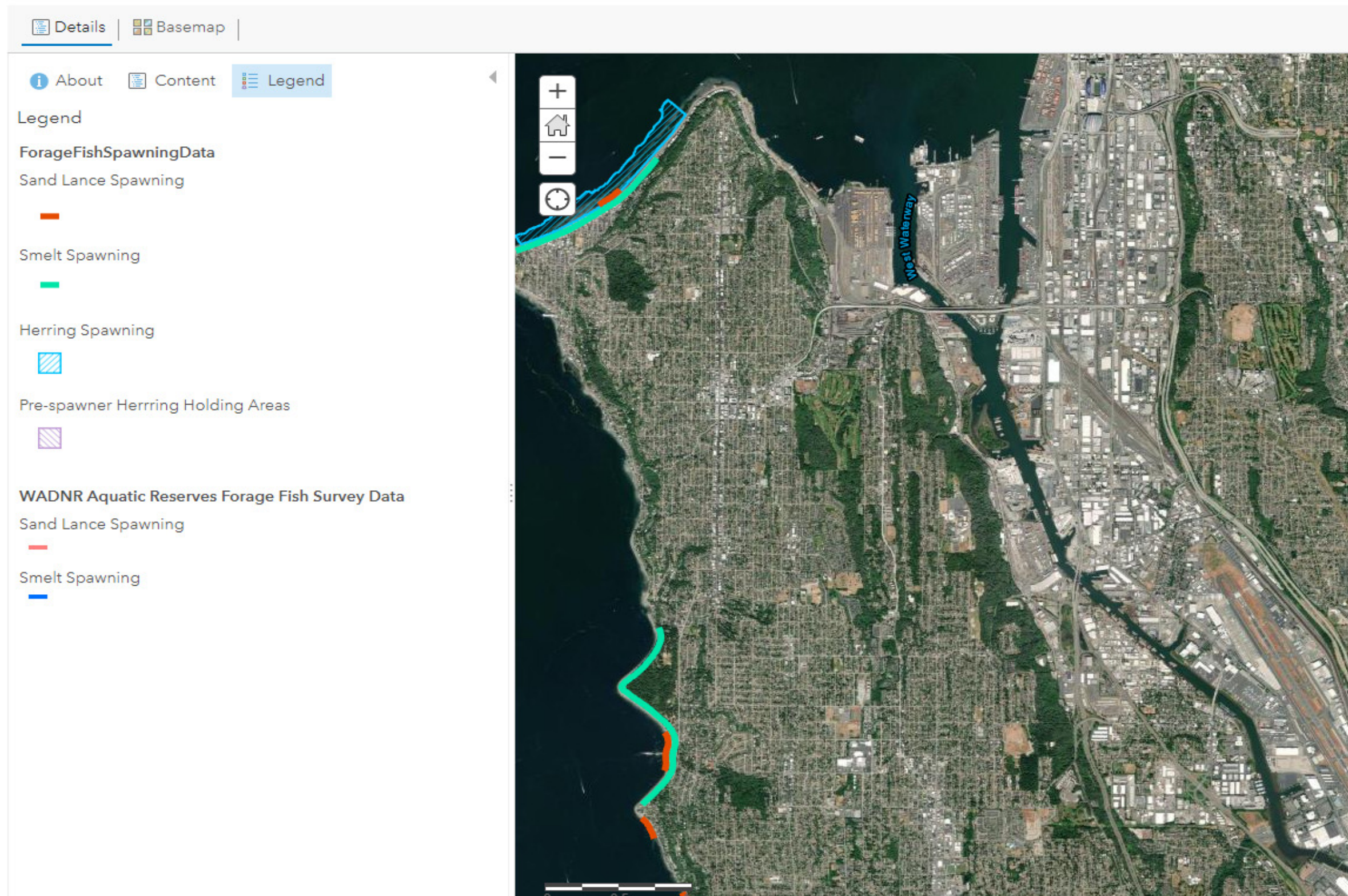

Drift Cells (nearest to project area)



Coastal Atlas

Legend Zoom Tools Home Add/Remove Map Data

^ Drift Cells

- Left to right
- No appreciable drift
- Right to left

^ Coastal Landforms

- Feeder bluff exceptional
- Feeder bluff
- Transport zone
- Feeder bluff – Talus
- Accretion shoreform
- Pocket beach
- Pocket beach - artificial

No appreciable drift:

- Artificial
- Bedrock
- Delta
- Low energy

Map Layers Geographic Demographic

Drift cell: No Appreciable Drift more

Legend Zoom Tools Home Add/Remove Map Data

Find address or place

Map Layers Geographic Demographic

Coastal landform: No appreciable-drift: Artificial more

Drift Cells

- Left to right
- No appreciable drift
- Right to left

Coastal Landforms

- Feeder bluff exceptional
- Feeder bluff
- Transport zone
- Feeder bluff – Talus
- Accretion shoreform
- Pocket beach
- Pocket beach - artificial

No appreciable drift:

- Artificial
- Bedrock
- Delta
- Low energy

Habitat Impact and Benefit Determination for the Riparian Zone

Habitat Impact and Benefit Determination for the Riparian Zone

Only fill out this tab if your project has changes to the Riparian Zone. The Riparian Zone encompasses the area within 40 meters (130 feet) of HAT. There may be locations in which woody vegetation growth extends below HAT, especially in areas with stabilized shorelines. In those locations, the area where woody vegetation is planted for mitigation may be entered in this tab, including any areas below HAT.

Riparian enhancements occurring within the same basin as the habitat impact site can be evaluated here. They do not need to occur on the same site. See the User Guide for extended information on how to enter Before/After Scenarios in this tab.

General Project Factors

			Notes	
Duration	Are the project impacts permanent?	Yes/No (see note)	Yes	If project impacts or benefits are not permanent, select NO. *Proof of legal site protection (like a conservation easement) is needed to click "Yes"
	If temporary, enter the years of project impact.	Temp Impact Years		If permanent, ("Yes" above), leave blank. Otherwise, enter the number of years the project will exist. <u>Leave at 10 unless a conservation easement exists</u> or adjust to less than 10 if planting coverage could be changed.
	Add time delay between impact and vegetation restoration in number of years.		1	Enter 0 for habitat loss and restoration within same year. Otherwise, enter a number. For example, entering 2 indicates a 2 year delay between habitat loss and restoration.

Habitat Evaluation

Enter the square footage of CHANGES ONLY for each cover type below (described in cells B13, B14, B15, B16) between before and after riparian work. For example, if there are 1000 sqft of shrubs before and 1000 sqft of impervious after, enter 1000 in cell E14 and 1000 in cell G16. Do not enter the riparian area for an entire property. If area is entered in column E, the changes must be entered into different riparian categories (not the same cover type in both before and after). No area in the "before" cell can remain in the same cover type for after. Conditional formatting will gray the "after" cell to show that the after area should be "0". The total square footage before the changes should equal the total square footage after the changes.

#	Indicator of Physical Habitat Question	Riparian Habitat Value	Before		After		Time until fully functioning (years)	Elements of Nearshore Marine PCEs addressed	Notes
			Area [sqft]	Habitat Value times discounting factors	Area [sqft]	Habitat Value times discounting factors			
1a	TREES: How many sqft of the riparian area that will be improved or degraded within 130 feet landward of HAT along length of shoreline action area are vegetated with trees: native woody vegetation.	0.55	1800	0.26		0.28	20	F, C	For a restored area to count as tree cover the performance standard is: Minimum of 90% tree canopy cover with shrubs in understory at 20 years.
1b	SHRUBS: How many sqft of the riparian area that will be improved or degraded within 130 feet landward of HAT along length of shoreline action area are vegetated with shrubs, native woody vegetation.	0.40	0	0.19		0.20	10	F, C	
1c	HERBACEOUS VEG: How many sqft of the riparian area that will be improved or degraded within 130 ft width along length of shoreline action area are vegetated with lawn, herbaceous vegetation, or invasive vegetation? Include all invasive vegetation in this category, regardless of type/size.	0.10	0	0.05	0	0.05	1.0	F, C	How Habitat Values and Discount Factors were scaled: A shrub at 49 ft from the water should provide more value to fish (allochthonous input) than grass. Most of the 0.1 habitat value for grass is attributed to infiltration and WQ function.
1d	IMPERVIOUS SURFACE or UNVEGETATED: How many sqft of the riparian area that will be improved or degraded within 130 feet landward of HAT along length of shoreline action area are covered with mostly impervious surface like pavers, gravel, concrete, wood deck?	0.00	0	No discounting factors apply as value already 0.	1800	No discounting factors apply as value already 0.	1.0	F, C	
Discounting Factors		Answer Format	Discount Factors related to Distance & Connectivity						
1	Distance of riparian vegetation from the shoreline, bulkhead or HAT for natural shoreline. For example, if a row of trees is within 130 ft landward of HAT, but behind 10 feet of lawn with the lawn adjacent to the water, enter distance, 10 ft, in ft. Use half of the drip line to determine this distance.	0 ft to 130 ft	10	0.95	0	1.00			
2	Do structures between vegetation and shoreline reduce connectivity and function of native woody vegetation? Enter % [1-100] of area that is disconnected before and after project. If 100 % of considered area is disconnected/shielded from shoreline by buildings like a boat shed, enter 100.	0 to 100 percent	0	1.00	0	1.00			
	Is riparian vegetation disconnected from upper intertidal via armoring?		Yes	0.50	Yes	0.50			Discount factor for when riparian vegetation is disconnected by hard shoreline armoring like bulkheads and riprap from the USZ. When the woody riparian vegetation is disconnected from the USZ its ability to provide shade, food, and cover is diminished.
Total affected riparian area [sqft]. Square footage before and after needs to be the same.			1800.00	0.26	1800.00	0.00	1.00		
Total affected riparian area [acres]			0.04132						
Discount if vegetation is planted 130 feet away from water.		0.7	If vegetation is planted 130 feet from the shoreline (bulkhead or HAT) the habitat value of this vegetation is 30 percent of that immediately adjacent to the shoreline.						
Discount if vegetation is 100% disconnected from shoreline by vertical structures like boat houses.		0.9	If vegetation is 100% disconnected by structures like boat houses from shoreline, 10% of its value remains via some food/insects still reaching the water and infiltration of rainwater.						
DSAYs for USZ		-0.35							
Conservation Offsets/Habitat Loss		-34.75							

Impact and Benefit Determination for Overwater Structure Elements

Impact and Benefit Determination for Overwater Structure Elements

Entry Block I: New or Expansion Overwater Structure Elements

Enter **new overwater structure elements and all areas that are considered expansions with replacements** here in Entry Block I. To enter replacement and repair of overwater structure elements, use Entry Block II.

	Description	OWS Element	Units	Quantity	Habitat Loss	Notes and Examples	
Pier and Ramp to be Installed	Enter the dimensions of elevated piers and ramps in each respective shore zone. If a pier has partial grating, enter dimensions of grated and ungrated portions into respective fields. Enter central portions of piers wider than 40 feet as floats as there is little side lighting in such structures. Enter boatlifts as solid or grated piers, depending on design.	Pier & Ramp USZ fully grated	SqFt		0.00	To account for the dark center on wide decks, enter the deck area within 20 feet from the edge as pier, and enter the deck area more than 20 feet from the edge as a float. See Figure below. FYI: Forage fish credit factors do not apply to piers and ramps. Figure by Lee Corum (USFWS).	
		Pier & Ramp USZ solid	SqFt		0.00		
		Pier & Ramp LSZ fully grated	SqFt		0.00		
		Pier & Ramp LSZ solid	SqFt		0.00		
		Pier & Ramp DSZ fully grated	SqFt		0.00		
	Reference: Delineation of Shore Zones	Pier & Ramp DSZ solid	SqFt		0.00		
Piles	Piles can be steel, concrete, plastic, untreated wood or, treated and urea coated piles. Installation of creosote wood is not included. Use the Average Pile Diameter Calculator below to determine average pile diameter.	Number of piles in USZ			0.00		
		Average pile diameter in USZ	[inches]				
		Number of piles in LSZ			0.00		
		Average pile diameter in LSZ	[inches]				
		Number of piles in DSZ			0.00		
		Average pile diameter in DSZ	[inches]				
Grated Float to be Installed	Enter the outside dimensions of new floats with at least 50% grating and 60% or more open space as grated floats (Compliant with WAC 220-660-140). Grated floats are not split between grated and ungrated portions	USZ Outside dimensions of new float or expanded portion of float.	Length [feet]		Enter the length and width of floats proposed to be removed. For complex floats, enter the length and the width of the entire complex float system and manually enter the total area. See User Guide and Ref. tab for more instructions. Marinas may have multiple complex floats. For complex floats, the calculated square footage will not match the actual square footage. Enter the square footage manually in column E.		
			Width [feet]				
		LSZ Outside dimensions of new float or expanded portion of float.	Length [feet]				
			Width [feet]				
		DSZ Outside dimensions of new float or expanded portion of float.	Length [feet]				
			Width [feet]				
	The area of a float in each shore zone is calculated from the length and width entered above. For complex floats, enter the area directly in the appropriate zone. Floats should not be located in the USZ and cannot ground out.	Grated Float USZ	SqFt	0	0.00	-	Floats in DSZ: herring spawning and holding areas may have herring spawning factor applied, depending on size and design. See the User Guide for more information.
		Grated Float LSZ	SqFt	0	0.00	-	
		Grated Float DSZ	SqFt	0	0.00	-	
Float to be Installed	Enter the length and width of the float in the appropriate shore zone. For complex floats, enter longest outside dimensions of the float. Solid floats have higher adverse effects on the nearshore environment than grated floats. We highly encourage applicants to grate overwater structures.	USZ Outside dimensions of new float or expanded portion of float.	Length [feet]		Enter the length and width of floats proposed to be removed. For complex floats, enter the length and the width of the entire complex float system and manually enter the total area. See User Guide and Ref. tab for more instructions. Marinas may have multiple complex floats. For complex floats, the calculated square footage will not match the actual square footage. Enter the square footage manually in column E.		
			Width [feet]				
		LSZ Outside dimensions of new float or expanded portion of float.	Length [feet]				
			Width [feet]				
		DSZ Outside dimensions of new float or expanded portion of float.	Length [feet]				
			Width [feet]				

Solid Float	The area of a float in each shore zone is calculated from the length and width entered above. For complex floats, enter the area directly in the appropriate zone. Floats should not be located in the USZ and cannot ground out.	Solid Float USZ	SqFt	0	0.00	0	Floats in DSZ: herring spawning and holding areas may have herring spawning factor applied, depending on size and design. See the User Guide for more information.
		Solid Float LSZ	SqFt	0	0.00	0	
		Solid Float DSZ	SqFt	0	0.00	0	

Sub-Total: Habitat Loss due to New Structure Elements

0.00

[Reference: Delineation of Shore Zones](#)

Entry Block II: Repair and Replacement of Overwater Structure Elements

Enter replacement and repair of overwater structure elements here in Entry Block II.

	Description	OWS Element	Units	Quantity	Habitat loss	Notes and Examples			
Pier and ramp to be Installed	Enter the dimensions of elevated piers and ramps in each respective shore zone. If a pier has partial grating, enter dimensions of grating and ungrated portions into respective fields. Enter central portions of piers wider than 40 feet as floats as there is little side lighting in such structures. Enter boatlifts as solid or grating piers, depending on design. Reference: Delineation of Shore Zones	Pier & Ramp USZ fully grating	SqFt		0.00	To account for the dark center on wide decks, enter the deck area within 20 feet from the edge as pier, and enter the deck area more than 20 feet from the edge as a float. See Figure below. FYI: Forage fish credit factors do not apply to piers and ramps. Figure by Lee Corum.			
		Pier & Ramp USZ solid	SqFt		0.00				
		Pier & Ramp LSZ fully grating	SqFt		0.00				
		Pier & Ramp LSZ solid	SqFt		0.00				
		Pier & Ramp DSZ fully grating	SqFt		0.00				
		Pier & Ramp DSZ solid	SqFt		0.00				
Piles	Piles can be steel, concrete, plastic, untreated wood or treated and urea coated piles. Installation of creosote wood is not included. Use the Average Pile Diameter Calculator below to determine average pile diameter.	Number of piles in USZ			0.00				
		Average pile diameter in USZ	[inches]						
		Number of piles in LSZ		2	-1.36				
		Average pile diameter in LSZ	[inches]	14.00					
		Number of piles in DSZ			0.00				
		Average pile diameter in DSZ	[inches]						
Grated Float to be Installed	Enter the outside dimensions of new floats with at least 50% grating and 60% or more open space as grating floats (Compliant with WAC 220-660-140). Grating floats are not split between grating and ungrating portions	USZ Outside dimensions of replacement float.	Length [feet]		Enter the length and width of floats proposed to be removed. For complex floats, enter the length and the width of the entire complex float system and manually enter the total area. See User Guide and Ref. tab for more instructions. Marinas may have multiple complex floats. For complex floats, the calculated square footage will not match the actual square footage. Enter the square footage manually in column E.				
			Width [feet]						
		LSZ Outside dimensions of replacement float.	Length [feet]				Reference: Complex Floats	Buffer Area	
			Width [feet]						
		DSZ Outside dimensions of replacement float.	Length [feet]						0
			Width [feet]						
The area of a float in each shore zone is calculated from the length and width entered above. For complex floats, enter the area directly in the appropriate zone. Floats should not be located in the USZ and cannot ground out.	Grated Float USZ	SqFt	0	0.00	0	Floats in DSZ: herring spawning and holding areas may have herring spawning factor applied, depending on size and design. See the User Guide for more information.			
	Grated Float LSZ	SqFt	0	0.00	0				
	Grated Float DSZ	SqFt	0	0.00	0				

Solid Float to be Installed	Enter the length and width of the float in the appropriate shore zone. For complex floats, enter longest outside dimensions of the float. Solid floats have higher adverse effects on the nearshore environment than grated floats. We highly encourage applicants to grate overwater structures	USZ Outside dimensions of replacement float.	Length [feet]		Enter the length and width of floats proposed to be removed. For complex floats, enter the length and the width of the entire complex float system and manually enter the total area. See User Guide and Ref. tab for more instructions. Marinas may have multiple complex floats. For complex floats, the calculated square footage will not match the actual square footage. Enter the square footage manually in column E.	
			Width [feet]			
		LSZ Outside dimensions of replacement float.	Length [feet]			
			Width [feet]			
		DSZ Outside dimensions of replacement float.	Length [feet]			
			Width [feet]		Reference: Complex Floats	Buffer Area
	The area of a float in each shore zone is calculated from the length and width entered above. For complex floats, enter the area directly in the appropriate zone. Floats should not be located in the USZ and cannot ground out.	Solid Float USZ	SqFt	0	0.00	0
Solid Float LSZ		SqFt	0	0.00	0	
Solid Float DSZ		SqFt	0	0.00	0	
Sub-Total: Habitat Loss due to Replacement Structure Elements				-1.36		

Entry Block III: Removal, Removal as Part of Replacements, and Repair of Overwater Structure Elements

Determine benefits from both structures to be removed as part of replacements or from structures in close proximity to be removed as mitigation for new structures.

Pier and Ramp to be Removed	Description	OWS Element	Units	Quantity	Habitat benefit	Notes and Examples
Pier and Ramp to be Removed	Enter the dimensions of elevated piers and ramps in each respective shore zone. If a pier has partial grating, enter dimensions of grated and ungrated portions into respective fields. Enter central portions of piers wider than 40 feet as floats as there is little side lighting in such structures. Enter boatlifts as solid or grated piers, depending on design.	Pier & Ramp <u>USZ</u> fully grated	SqFt		0.00	To account for the dark center on wide decks, enter the deck area within 20 feet from the edge as pier, and enter the deck area more than 20 feet from the edge as a float. See Figure below. FYI: Forage fish credit factors do not apply to piers and ramps.
		Pier & Ramp <u>USZ</u> solid	SqFt		0.00	
		Pier & Ramp LSZ fully grated	SqFt		0.00	
		Pier & Ramp LSZ solid	SqFt		0.00	
		Pier & Ramp DSZ fully grated	SqFt		0.00	
		Reference: Delineation of Shore Zones	Pier & Ramp DSZ solid	SqFt		
Piles to be removed	Include all piles to be removed including creosote. The amount of creosote is credited separately below. Use the Average Pile Diameter Calculator below to determine average pile diameter.	Number of piles in USZ		17	2.18	
		Average pile diameter in USZ.	[inches]	10.00		
		Number of piles in LSZ		13	1.67	
		Average pile diameter in LSZ.	[inches]	10.00		
		Number of piles in DSZ			0.00	
		Average pile diameter in DSZ.	[inches]			
Creosote Removal	Creosote removal: Enter tons of creosote to be removed including all in- and over water creosote. A volume calculator is provided below.	Tons of Creosote to be removed in USZ	Total in tons	0.89	1.61	Benefit duration for creosote removal is 100 years. Absent removal of piles, we assume that derelict piles on average break off after 40 years. Thus site specific credit factors apply for 40 years, only.
		Tons of Creosote to be removed in LSZ & DSZ	Total in tons	0.60	1.07	

Grated Float to be Removed	Enter the outside dimensions of new floats with at least 50% grating and 60% or more open space as grated floats (Compliant with WAC 220-660-140). Grated floats are not split between grated and ungrated portions	USZ Outside dimensions of float area	Length [feet]		Enter the length and width of floats proposed to be removed. For complex floats, enter the length and the width of the entire complex float system and manually enter the total area. See User Guide and Ref. tab for more instructions. Marinas may have multiple complex floats. For complex floats, the calculated square footage will not match the actual square footage. Enter the square footage manually in column E.			
			Width [feet]					
		LSZ Outside dimensions of float area.	Length [feet]					
			Width [feet]					
Solid Float to be Removed	Enter the length and width of the float in the appropriate shore zone. For complex floats, enter longest outside dimensions of the float.	USZ Outside dimensions of solid float.	Length [feet]		Enter the length and width of floats proposed to be removed. For complex floats, enter the length and the width of the entire complex float system and manually enter the total area. See User Guide and Ref. tab for more instructions. Marinas may have multiple complex floats. For complex floats, the calculated square footage will not match the actual square footage. Enter the square footage manually in column E.			
			Width [feet]					
		LSZ Outside dimensions of solid float	Length [feet]					
			Width [feet]					
Grated Float to be Removed	The area of a float in each shore zone is calculated from the length and width entered above. For complex floats, enter the area directly in the appropriate zone. Floats should not be located in the USZ and cannot ground out.	Grated Float USZ	SqFt	0	0.00	0	Floats in DSZ: herring spawning and holding areas may have herring spawning factor applied, depending on size and design. See the User Guide for more information.	
		Grated Float LSZ	SqFt	0	0.00	0		
		Grated Float DSZ	SqFt	0	0.00	0		
		Sub-Total: Conservation Offsets gained from the Removal of Existing Structures					6.53	

Average Pile Diameter Calculator

For projects with multiple piles and pile diameters, use this entry area to determine the average pile diameter. The average pile diameter will then be used above with the total number of piles proposed.

Piles to be removed	Description	Quantity	Pile Diameter (inches)	RAA	Habitat Zone	Creosote coated
		Number of piles with one diameter size	2	10	24/25, 26	LSZ
	Number of piles with one diameter size	3	10		27 LSZ	yes
	Number of piles with one diameter size	1	10		27 LSZ	yes
	Number of piles with one diameter size	9	10	30/31	USZ	yes
	Number of piles with one diameter size	2	10		32 LSZ	no
	Number of piles with one diameter size	5	10	33/34/35	LSZ	no
	Number of piles with one diameter size (fill in diameter as needed)	8	10	33/34/35	USZ	no
	Number of piles with one diameter size (fill in diameter as needed)					
	Total number of piles and average pile size	30	10.00	piles in LSZ		13
				piles in USZ		17

For projects with multiple piles and pile diameters, use this entry area to determine the average pile diameter. The average pile diameter will then be used above with the total number of piles proposed.

Piles to be installed	Description	Quantity	Pile Diameter (inches)
	Number of piles with one diameter size	1	14
	Number of piles with one diameter size	1	14
	Number of piles with one diameter size		
	Number of piles with one diameter size		
	Number of piles with one diameter size		
	Number of piles with one diameter size (fill in diameter as needed)		
	Number of piles with one diameter size (fill in diameter as needed)		
	Total number of piles and average pile size	2	14.00

RAA Habitat Zone
24/25, 26 LSZ
27 LSZ

Pile Volume Calculator for Creosote Tonnage Estimation

Creosote Piles to be removed	Description	Quantity	Pile Diameter (inches)	Pile Length (feet)	Volume (Cubic Feet)
	Number of piles with same dimensions	6	10	10	32.72
	Number of piles with same dimensions				0.00
	Number of piles with same dimensions				0.00
	Number of piles with same dimensions				0.00
	Number of piles with same dimensions				0.00
	Number of piles with same dimensions				0.00
	Optional: Enter total volume of creosote material (non-pile) (cubic feet)				0.00
	Total Volume of piles (cubic feet)				32.72
	Creosote tonnage (1 ton per 55 cubic feet)	To be entered in Cell E100 and or E101			0.60

Habitat Zone
LSZ

Pile Volume Calculator for Creosote Tonnage Estimation

Creosote Pile Description	Quantity	Pile Diameter (incl	Pile Length (feet)	Volume (Cubic Feet)	Habitat Zone
Number of piles with same dimensions	9	10	10	49.08738521	USZ
Number of piles with same dimensions				0	
Number of piles with same dimensions				0	
Number of piles with same dimensions				0	
Number of piles with same dimensions				0	
Number of piles with same dimensions				0	
Optional: Enter total volume of creosote material (non-pile) (cubic feet)				0	
Total Volume of piles (cubic feet)				49.08738521	
Creosote tonnage (1 ton per 55 cubic feet)	To be entered in Cell E100 and or E101			0.892822576	

Impact and Benefit Determination for Concrete Boat Ramps, Jetties, Concrete Rubble

Impact and Benefit Determination for Concrete Boat Ramps, Jetties, Concrete Rubble

Entry Block I: New and Expanded Elements of Existing Structures

Enter **new boat ramps, jetties, breakwaters, and all areas that are considered expansions of existing or to-be-replaced structures** here in Entry Block I. To enter replacement structure elements, use Entry Block II.

Boat ramp Installation

Boat Ramp and Concrete/Footing Installation	Description		Units	Quantity	Conservation Points	Notes	
	Is this a Boat ramp installation? "No" indicates installation of concrete footings, or similar with no impact on water quality or shore drift (USZ).		yes/no	No			
	USZ	Length of boat ramp to be installed	Ft	160		Dimensions are used to estimate area where interruption of longshore drift occurs.	
		Width of boat ramp to be installed	Ft	1.5			
		USZ: Area of boat ramp, concrete footing, or similar to be installed	SqFt	240.00	-8.60	Includes impact to longshore drift from boat ramps and jetties if E10 = Yes. If E10 = No, area of concrete or similar structure can be entered directly in E14.	
	LSZ	LSZ: Area of boat ramp, concrete footings, or similar to be installed	SqFt		0.00	No shore drift interruption considered for LSZ.	
DSZ	DSZ: Area of boat ramp to be installed	SqFt		0.00	No shore drift interruption considered for DSZ.		

Jetty Installation

Jetty Installation	Description		Units	Quantity	Conservation Points	Notes
	USZ	Length of jetty to be installed	Ft			Dimensions are used to estimate area where interruption of longshore drift occurs.
		Width of jetty to be installed	Ft			
		USZ: Area of jetty to be installed	SqFt	0	0.00	
	LSZ	LSZ: Area of jetty to be installed	SqFt		0.00	No shore drift interruption considered for LSZ.
	DSZ	DSZ: Area of jetty to be installed	SqFt		0.00	No shore drift interruption considered for DSZ.

Habitat loss due to installation

Total

-8.60

Entry Block II: Replacement Structures

Enter **replacement boat ramps, jetties, and breakwaters** here in Entry Block II. Then enter the to-be-removed structure elements in Entry Block III.

Boat ramp Replacement

Boat Ramp and Concrete/Footing Replacement	Description		Units	Quantity	Habitat loss	Notes
	Is this a Boat ramp installation? "No" indicates installation of concrete footings, or similar with no impact on water quality or shore drift.		yes/no	No		
	USZ	Length of boat ramp to be installed	Ft			Dimensions are used to estimate area where interruption of longshore drift occurs.
		Width of boat ramp to be installed	Ft			
		USZ: Area of boat ramp, concrete footing, or similar to be installed	SqFt	0.00	0.00	Includes average impact to longshore drift - 4 ft on either side of boat ramp.
	LSZ	LSZ: Area of boat ramp, concrete footings, or similar to be installed	SqFt		0.00	No shore drift interruption considered for LSZ.
DSZ	DSZ: Area of boat ramp to be installed	SqFt		0.00	No shore drift interruption considered for DSZ.	

Jetty Replacement

Jetty Replacement	Description		Units	Quantity	Conservation Points	Notes
	USZ	Length of jetty to be installed	Ft			Dimensions are used to estimate area where interruption of longshore drift occurs.
		Width of jetty to be installed	Ft			
		USZ: Area of jetty to be installed	SqFt	0	0.00	
	LSZ	LSZ: Area of jetty to be installed	SqFt		0.00	No shore drift interruption considered for LSZ.
	DSZ	DSZ: Area of jetty to be installed	SqFt		0.00	No shore drift interruption considered for DSZ.
Habitat loss due to replacement			Total		0.000	

Entry Block III: Removal of Old Structures

Enter **boat ramps, jetties, and breakwaters proposed to be removed, repaired, or replaced** here in Entry Block III.

Boat ramp and Rubble/Debris Removal

Boat Ramp and Concrete Rubble Removal	Description		Units	Quantity	Conservation offsets	Notes	
	Is this a Boat ramp removal? "No" indicates removal of rubble or concrete pieces.		yes/no	No			Boat ramp has to be in functioning conditions for boat ramp removal credit. Otherwise enter as rubble.
	USZ	Length of boat ramp to be removed	Ft				
		Width of boat ramp to be removed	Ft				
		USZ: Area of boat ramp, concrete, or rubble to be removed; incl. shoreline drift restored by boat ramp removal	SqFt	1859	12.29	For the removal of several piece of concrete or rubble, enter the combined square footage in E62 rather than enter in length and width.	
	LSZ	LSZ: Area of boat ramp, concrete, or rubble to be removed	SqFt		0.00	No shore drift interruption considered for LSZ.	
DSZ	DSZ: Area of boat ramp, concrete, or rubble to be removed	SqFt		0.00	No shore drift interruption considered for DSZ.		

Jetty Removal

Jetty Removal	Description		Units	Quantity	Conservation offsets	Notes	
	USZ	Length of jetty to be removed	Ft				Dimensions are used to estimate impact from interruption of longshore drift.
		Width of jetty to be removed	Ft				
		USZ: Area of jetty to be removed	SqFt	0	0.00		
	LSZ	LSZ: Area of jetty to be removed	SqFt		0.00	No shore drift interruption considered for LSZ.	
	DSZ	DSZ: Area of jetty to be removed	SqFt		0.00	No shore drift interruption considered for DSZ.	
Conservation offsets gained from removal			Total		12.29		

Reference

To return to the previous worksheet and location press F5 + Enter keys simultaneously.

Table 1: Scenarios for Lower Shore Zone: Submerged Aquatic Vegetation (SAV) within 25 feet of Project Area

VEGETATION SCENARIO	Native Eelgrass and/or Kelp	Other SAV (no native eelgrass or kelp present)
Scenario 0	N/A	≤ 10%
Scenario 1	1-25% Combined SAV	11-25%
Scenario 2	26-69% Combined SAV	26-75%
Scenario 3	≥ 70% Combined SAV	> 75%

*SAV is defined as rooted vascular plants and attached macroalgae. Drift algae and *Ulva spp.* are not included when determining cover percentage except where *Ulva spp.* occurs in documented herring spawning areas.

EXAMPLE: A site in the LSZ has 25% native eelgrass and 45% other SAV (combined SAV total 70%) within 25 feet of project area. This would be Scenario 3 because native eelgrass is present within 25 feet of the project area.

Table 2: Scenarios for Upper Shore Zone: Upper Intertidal Vegetation within 25 feet of Project Area

VEGETATION SCENARIO	Macro algae and saltmarsh vegetation like <i>Salicornia sp.</i> and <i>Distichlis sp.</i>
Scenario 0	Less than 5% of cover
Scenario 1	Between >5% and < 30% of cover
Scenario 2	Between >30% and <60% of cover
Scenario 3	Over 60% of cover

Table 3: Delineation of Shore Zones

NEARSHORE ZONE	Description
Riparian Zone	HAT to 130 feet landward of HAT
Upper Shore Zone (USZ)	HAT to +5 feet MLLW
Lower Shore Zone (LSZ)	+5 feet MLLW to -10 feet MLLW and limits of SAV
Deeper Shore Zone (DSZ)	Deeper than -10 feet MLLW or outer limits of SAV

Nearshore Zones

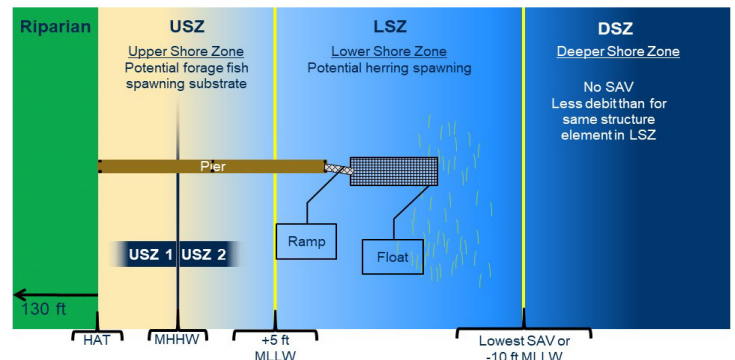

Figure by Lee Corum, USFWS

Examples of Complex Floats and Calculator Entry

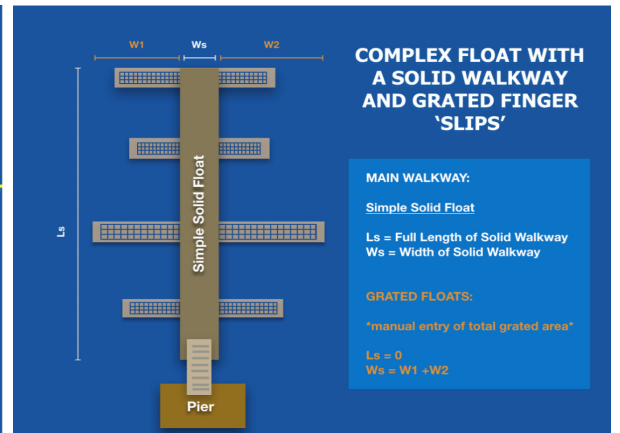
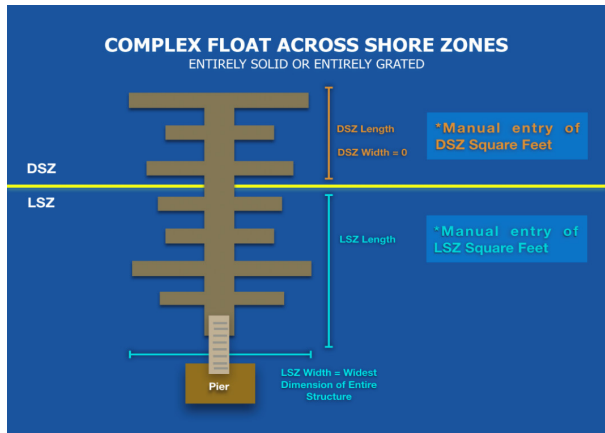
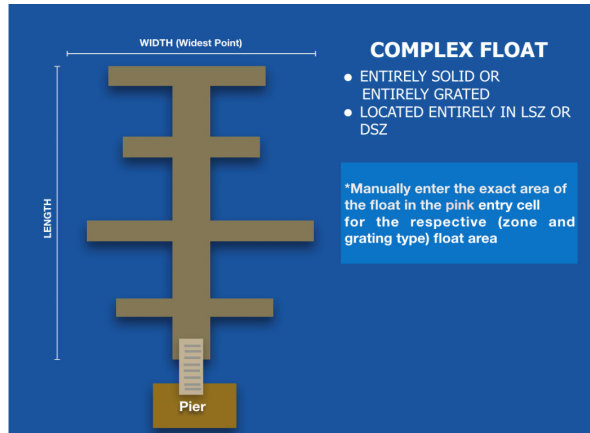

Figure 2: Application of Credit Factors

Not all credit factors are applied for all structures or all shore zones. See the table below for applicability of each. Credit factors apply to the entire elevation polygon, they do not reflect a before after change. They are a function of inherent site conditions.

Credit factors for water quality benefits related to creosote removal are 40% of full credit factors because we expect creosote piles to be on site for approximately 40 years of the 100 year assumed benefit period.

Nearshore Impact	Major Estuary Zone	Pocket Beach	Feeder Bluff	Sand lance or surf smelt spawning	Updrift of FF spawning within same drift cell	Herring spawning
Shoreline armoring	XX	XX	XX	XX	XX	In rare cases
Piers and ramps	XX	XX				
Piles depending on zone	XX	XX	XX	XX		XX
Floats (USZ)	XX	XX		XX	In rare cases	
Floats (LSZ)	XX	XX				XX
Floats (DZ)	XX	XX				depends
Creosote Piles WQ benefit	X	X		X		X
Boat ramps & Jetties (USZ)	XX	XX	XX	XX	In rare cases	
Boat ramps & Jetties (LSZ)	XX	XX				XX
Boat ramps & Jetties (DZ)	XX	XX				
Beach Nourishment	XX	XX		XX	XX	
Riparian	XX	XX	XX	XX		

Explanation of Pocket Estuaries and Embayment's

While the GIS layer for "Major Estuary Zones" and "Pocket Estuary or Embayment" is depicted as a band (this is an artifact of how the GIS layer was created), these landscape-scale credit/debit factors apply to all zones and the entire structure. In other words, if any part of a structure is at a location that is mapped as either "Major Estuary Zones" and/or "Pocket Estuary or Embayment", this credit factor applies to all parts of that structure not just the parts that are located on the band shown on the GIS layer; also see Figure 2.

[The online GIS layer to determine Natal and Pocket Estuaries](#)

Many classification systems have been created and refined to describe Puget Sound shoreline habitats (Shipman 2008, McBride 2009). Many of these systems are based on a combination of geomorphic, oceanographic, chemical, and biological characteristics (McBride 2009). When using the term 'pocket estuary' we include embayment's, estuaries, and lagoons. The Geographic Information System (GIS) layer we use to designate Puget Sound Natal and Pocket Estuaries also encompasses these geomorphic types.

Cereghino et al. (2012) proposed two classes of embayment site: coastal inlets, which are formed such that their protected shallow structures are not dependent on beach dynamics for their existence, and barrier-type, which are embedded in a beach system and are somewhat dependent on a barrier beach for wave protection and wetland development. We also drew upon Shipman (2008) who uses the term embayment to include protected estuaries and lagoons where there is little wave action to form beaches. Estuaries are those with a significant input of freshwater from a surface stream, whereas lagoons have limited freshwater input. Both are tidally influenced. Natal estuaries are often recognized as important habitats for juvenile salmonids in Puget Sound for passage to and from freshwater and/or for extended rearing (Greene et al. 2017). However, in addition, the use of nonnatal estuaries and intertidal areas along the shoreline have been shown to be important habitats for juvenile Chinook salmon during migration in the Puget Sound (Hayes et al. 2019, Beamer et al. 2013).

90% Remedial Design Basis of Design Report

Attachment E.6.3

PNSC Workbook 2 of 2

Pugent Sound Nearshore Habitat Conservation Calculator

Summary

Blue cells contain section headings
 Rose cells contain questions that need to be answered to fill out calculator
 Grey cells contain units requested for entry
 Yellow cells indicate user entry fields
 Green cells contain additional explanations and resource links
 Maroon cells contain summary values

Action Agency Reference #	
FWS or NMFS #	
Project Name:	Lower Duwamish Waterway Upper Reach Remedial Design
Prepared on and by:	Workbook 2 of 2, 16-May-2022, Sydney Gonsalves (Anchor QEA)

Puget Sound Nearshore Habitat Conservation Calculator

Version 1.5 **2/24/2023**

This tool determines long-term habitat impacts and benefits for projects in the Salish Sea nearshore. Details about the use of this Conservation Calculator can be found in the User Guide, FAQs, and training materials, which are all available on the [Puget Sound Nearshore Habitat Conservation Calculator Webpage](#)

		Conservation Credits/Debits	DSAYs (Discounted Service Acre Years)
Overwater Structures	Debit	0	0.00
	Credit (includes creosote removal)	0	0.00
	Balance	0	0.00
Shoreline Armoring	Debit	0	0.00
	Credit from Armor Removal	0	0.00
	Credit from Creosote Removal	0	0.00
	Balance	0	0.00
Maintenance Dredging	Balance	0	0.00
Boatramps, Jetties, Rubble	Debit	0	0.00
	Credit	0	0.00
	Balance	0	0.00
Beach Nourishment	Conservation Offsets	0	0.00
Riparian Enhancement/Degradation	Balance	131	1.31
SAV Planting	Conservation Credit	0	0.00
Habitat Loss / Remaining Conservation Offsets Needed		0	0.00

Is this a standalone restoration project?*	No		
---------------------------------------------------	-----------	--	--

* Standalone restoration actions are actions that can be executed outside of a replacement or construction of new structures. They have no negative long term habitat impacts. A standalone restoration action solely restores or improves habitat functions. It does not introduce new or temporarily extend adverse effects aside from construction-related effects. Standalone restoration projects include removal of a structure (that has adverse effects) without its replacement.

Project Details

Project Details

Include all metrics and rationale used to fill out this Calculator. Note where you found all relevant information (JARPA, BE, other).

Orange cells contain questions from NMFS for the applicant or agency.

Project Name:	Lower Duwamish Waterway Upper Reach Remedial Design		
Marine Basin:	South Central Puget Sound	Click on the Beach Slope Reference Line at the project location to find the Marine Basin Name and other information.	
Location (lat, long):	47.532268 N, 122.319532 W (Web Mercator)		
Project Description:	The Lower Duwamish Waterway Group (LDWG), in coordination with the U.S. Environmental Protection Agency (EPA) and Washington State Department of Ecology (Ecology), is implementing a cleanup remedy for the upper reach of the Lower Duwamish Waterway (LDW) Comprehensive Environmental Response, Compensation, and Liability Act (CERCLA, or Superfund) Site in King County, Washington (EPA Site No. WA00002329803). The LDW Superfund Site extends 5 miles upstream from the southern tip of Harbor Island to just upstream of the Turning Basin at river mile (RM) 5; the upper reach comprises the furthest upstream two RMs: 3.0 to 5.0.		
Elements entered in this Calculator:	Workbook 1 of 2: Riparian habitat disturbed during construction (RZ), piles removed and installed during construction (Overwater Structures), bulkhead wall replacement (InputShorl and ShoreStab), debris removal (BoatR, Jetty). Workbook 2 of 2: Riparian habitat restored after construction (RZ), shoreline armoring replacement (InputShorl and ShoreStab)		

Site Specific Factors

Enter site specific credit factors and submerged aquatic vegetation (SAV) scenarios in the yellow boxes below. They will auto-apply to all tabs. If more than one project location exists, enter each location in a separate calculator file and submit both.

	Yes or No	% Change	Applicable to:	Ref: Application of Factors
Natal Estuary	No	0%	All tabs	
Is the project within 5 miles of a Puget Sound Chinook natal estuary or 1 mile of a Hood Canal summer-chum natal estuary? If yes, a factor of 50% applies. A project in both natal estuary and pocket estuary/embayment receives a combined 90% factor.				
Pocket Estuary or Embayment	No	0%	All tabs	Ref: Pocket Estuaries and Embayments
Is the project located within a pocket estuary/embayment? If yes, a factor of 30% applies. If also within a natal estuary zone, a factor of 40% applies.				
Forage Fish Spawning	No	0%	USZ for all tabs	
Is there sand lance or surf smelt spawning on the project site (as mapped or determined by WDFW)? If yes, a factor of 50% applies.				
Same Drift Cell and Updrift of Forage Fish	No	0%	USZ for ShoreStab, BoatRJetty, Beach N	Use Coastal Atlas "Drift Cells" map layer along with WDFW Forage Fish Spawning map
Is the project within the same drift cell <i>and</i> updrift of sand lance or surf smelt spawning? If yes, a factor of 20% applies <i>if</i> there is no forage fish spawning documented.				
Herring Spawning	No	0%	LSZ and DSZ structures in all tabs except RZ	Overwater structures in DSZ herring spawning and holding areas may have herring spawning factor applied depending on size and design. See the User Guide for more information.
Does the project site have documented herring spawning (as mapped or determined by WDFW)? If yes, a factor of 50% applies.				
Feeder Bluff	No	0%	RZ, ShoreStab	Use Coastal Atlas "Coastal Landforms" map layer
Is the project located at a feeder bluff? If yes, a factor of 50% applies.				
LSZ Submerged Aquatic Vegetation (SAV) and USZ Upper Intertidal Vegetation Scenario				
Upper Shore Zone	0	Select a number 1 - 3. Vegetation scenarios should be based on the average plant density in the footprint of the structure including a 25-foot buffer around the structure.		
Lower Shore Zone	0			

Document additional project information below.

Please see Workbook 1 of 2 for other project details, including site specific factors

Tab: RZ Note: Tab RZ in workbook 1 of 2 shows removal of trees near RAA 27 during construction and Tab RZ in workbook 2 of 2 shows replanting of removed trees plus planting of top-of-bank native riparian vegetation.

Riparian Area to be disturbed at RAA 27, from removal of existing riprap and placement of armor cap (514 ft length total) will include landscaped trees along the parking lot fence line. Non-native shrubs (Himalayan blackberry and butterfly bush) over riprap is not considered in analysis

Pre-Construction				Post-Construction - replanting of native shrubs		
Num Trees	Area (sq ft)	total area		Length (ft)	Width (ft)	Area (sq. ft)
9	200	1800	trees along fence	270	10	2700
				244	20	4880
						<u>7580</u> Total

Pre-Construction - trees along fence line above RAA 27

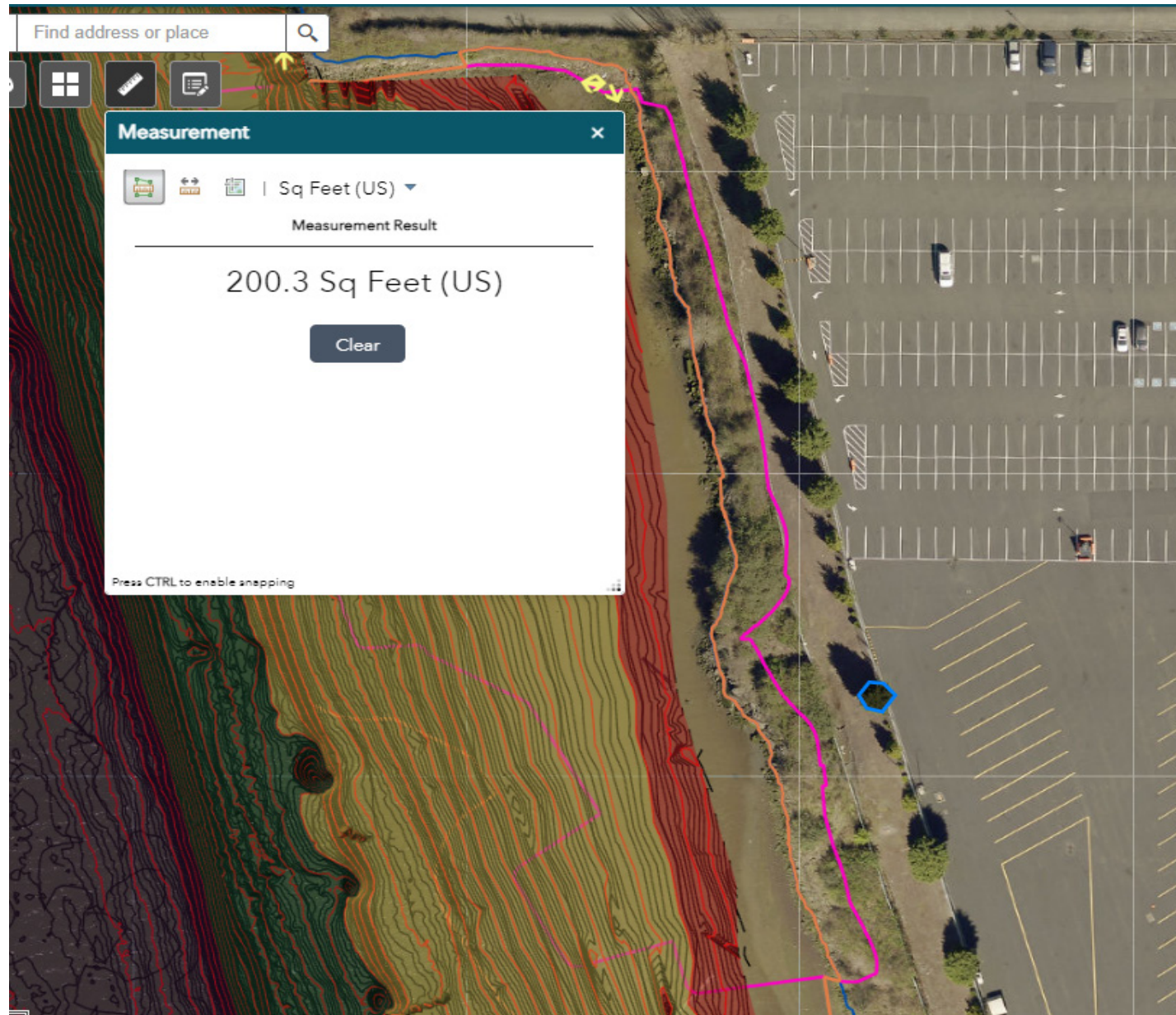

Post-Construction - cap area to be planted with native shrubby, fence line trees would also be replaced.

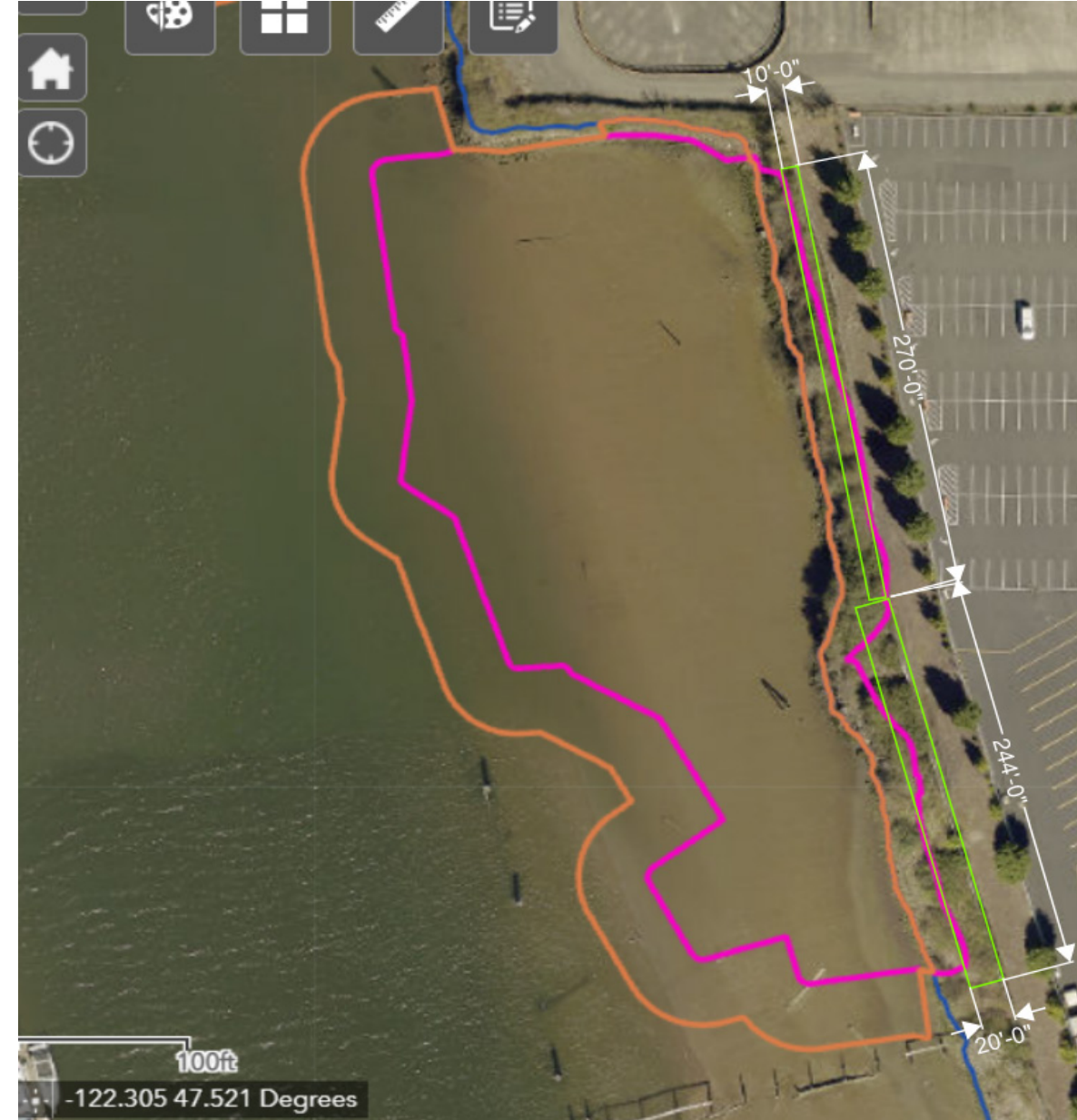

Habitat Impact and Benefit Determination for the Riparian Zone

Habitat Impact and Benefit Determination for the Riparian Zone

Only fill out this tab if your project has changes to the Riparian Zone. The Riparian Zone encompasses the area within 40 meters (130 feet) of HAT. There may be locations in which woody vegetation growth extends below HAT, especially in areas with stabilized shorelines. In those locations, the area where woody vegetation is planted for mitigation may be entered in this tab, including any areas below HAT.

Riparian enhancements occurring within the same basin as the habitat impact site can be evaluated here. They do not need to occur on the same site. See the User Guide for extended information on how to enter Before/After Scenarios in this tab.

General Project Factors

			Notes	
Duration	Are the project impacts permanent?	Yes/No (see note)	Yes	If project impacts or benefits are not permanent, select NO. *Proof of legal site protection (like a conservation easement) is needed to click "Yes"
	If temporary, enter the years of project impact.	Temp Impact Years		If permanent, ("Yes" above), leave blank. Otherwise, enter the number of years the project will exist. Leave at 10 unless a conservation easment exists or adjust to less than 10 if planting coverage could be changed.
	Add time delay between impact and vegetation restoration in number of years.		0	Enter 0 for habitat loss and restoration within same year. Otherwise, enter a number. For example, entering 2 indicates a 2 year delay between habitat loss and restoration.

Habitat Evaluation

Enter the square footage of CHANGES ONLY for each cover type below (described in cells B13, B14, B15, B16) between before and after riparian work. For example, if there are 1000 sqft of shrubs before and 1000 sqft of impervious after, enter 1000 in cell E14 and 1000 in cell G16. Do not enter the riparian area for an entire property. If area is entered in column E, the changes must be entered into different riparian categories (not the same cover type in both before and after). No area in the "before" cell can remain in the same cover type for after. Conditional formatting will gray the "after" cell to show that the after area should be "0". The total square footage before the changes should equal the total square footage after the changes.

#	Indicator of Physical Habitat Question	Riparian Habitat Value	Before		After		Time until fully functioning (years)	Elements of Nearshore Marine PCEs addressed	Notes	
			Area [sqft]	Habitat Value times discounting factors	Area [sqft]	Habitat Value times discounting factors				
1a	TREES: How many sqft of the riparian area that will be improved or degraded within 130 feet landward of HAT along length of shoreline action area are vegetated with trees: native woody vegetation.	0.55		0.26	1800	0.28	20	F, C	For a restored area to count as tree cover the performance standard is: Minimum of 90% tree canopy cover with shrubs in understory at 20 years.	
1b	SHRUBS: How many sqft of the riparian area that will be improved or degraded within 130 feet landward of HAT along length of shoreline action area are vegetated with shrubs, native woody vegetation.	0.40		0.19	7580	0.20	10	F, C		
1c	HERBACEOUS VEG: How many sqft of the riparian area that will be improved or degraded within 130 ft width along length of shoreline action area are vegetated with lawn, herbaceous vegetation, or invasive vegetation? Include all invasive vegetation in this category, regardless of type/size.	0.10	0	0.05	0	0.05	1.0	F, C	How Habitat Values and Discount Factors were scaled: A shrub at 49 ft from the water should provide more value to fish (allochthonous input) than grass. Most of the 0.1 habitat value for grass is attributed to infiltration and WQ function.	
1d	IMPERVIOUS SURFACE or UNVEGETATED: How many sqft of the riparian area that will be improved or degraded within 130 feet landward of HAT along length of shoreline action area are covered with mostly impervious surface like pavers, gravel, concrete, wood deck?	0.00	9380	No discounting factors apply as value already 0.	0	No discounting factors apply as value already 0.	1.0	F, C		
Discounting Factors		Answer Format	Discount Factors related to Distance & Connectivity							
1	Distance of riparian vegetation from the shoreline, bulkhead or HAT for natural shoreline. For example, if a row of trees is within 130 ft landward of HAT, but behind 10 feet of lawn with the lawn adjacent to the water, enter distance, 10 ft, in ft. Use half of the drip line to determine this distance.	0 ft to 130 ft	10	0.95	0	1.00				
2	Do structures between vegetation and shoreline reduce connectivity and function of native woody vegetation? Enter % [1-100] of area that is disconnected before and after project. If 100 % of considered area is disconnected/shielded from shoreline by buildings like a boat shed, enter 100.	0 to 100 percent	0	1.00	0	1.00				
	Is riparian vegetation disconnected from upper intertidal via armoring?		Yes	0.50	Yes	0.50	Discount factor for when riparian vegetation is disconnected by hard shoreline armoring like bulkheads and riprap from the USZ. When the woody riparian vegetation is disconnected from the USZ its ability to provide shade, food, and cover is diminished.			
Total affected riparian area [sqft]. Square footage before and after needs to be the same.			9380.00	0.00	9380.00	0.21	11.92			
Total affected riparian area [acres]			0.21534							
Discount if vegetation is planted 130 feet away from water.		0.7	If vegetation is planted 130 feet from the shoreline (bulkhead or HAT) the habitat value of this vegetation is 30 percent of that immediately adjacent to the shoreline.							
Discount if vegetation is 100% disconnected from shoreline by vertical structures like boat houses.		0.9	If vegetation is 100% disconnected by structures like boat houses from shoreline, 10% of its value remains via some food/insects still reaching the water and infiltration of rainwater.							

DSAYs for USZ

1.31

Conservation Offsets/Habitat Loss

131.00

Restoration Calculator

Restoration Calculator

This sheet calculates the habitat service value of a single restoration treatment over a single habitat, with a single lift in habitat function.

Model Assumptions

Project Name	Riparian
Base year	2020
Discount Rate	3.00%
Site Area (acres)	0.21533517

Summary

DSAYs	1.31
DSAYs/Acre	6.08

Before Restoration Treatment

Habitat Value Before	0.00
Habitat Degradation Before	0
Baseline Service Value (0-1)	0

After Restoration Treatment

Treatment Year	2020
Habitat Value After	0.21
Habitat Degradation After	0
Restored Service Value (0-1)	0.214392324
Years to Full Function	11.92
Service Life (years)	300
Annual Increment	0.02
Full Function Year	2030.92

Habitat Value Over Project life

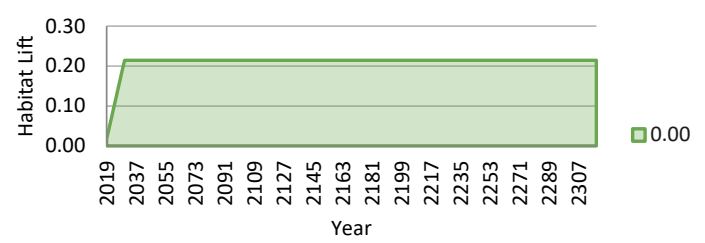

Cumulative Project DSAY Value

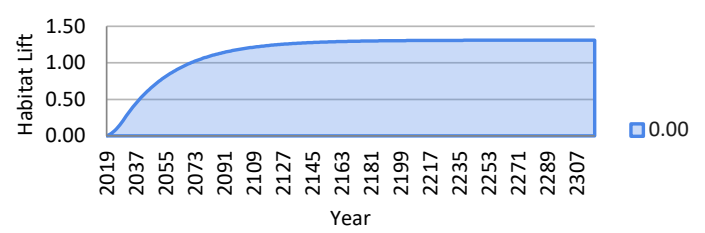

Year	Habitat Value Before	Habitat Value After	Habitat Lift	Service Acre Year Increment Gain	Service Acre Year Cumulative Gain	Discount Adjustment	DSAY Increment	DSAYs Cumulative
2019	0.00	0.00	0.00	0.0	0.0	103.0%	0.00	0.00
2020	0.00	0.02	0.02	0.0	0.0	100.0%	0.00	0.00
2021	0.00	0.04	0.04	0.0	0.0	97.0%	0.01	0.01
2022	0.00	0.05	0.05	0.0	0.0	94.1%	0.01	0.02
2023	0.00	0.07	0.07	0.0	0.0	91.3%	0.01	0.04
2024	0.00	0.09	0.09	0.0	0.1	88.5%	0.02	0.05
2025	0.00	0.11	0.11	0.0	0.1	85.9%	0.02	0.07
2026	0.00	0.13	0.13	0.0	0.1	83.3%	0.02	0.10
2027	0.00	0.14	0.14	0.0	0.1	80.8%	0.03	0.12
2028	0.00	0.16	0.16	0.0	0.2	78.4%	0.03	0.15
2029	0.00	0.18	0.18	0.0	0.2	76.0%	0.03	0.18
2030	0.00	0.20	0.20	0.0	0.3	73.7%	0.03	0.21
2031	0.00	0.21	0.21	0.0	0.3	71.5%	0.03	0.24
2032	0.00	0.21	0.21	0.0	0.3	69.4%	0.03	0.27
2033	0.00	0.21	0.21	0.0	0.4	67.3%	0.03	0.31
2034	0.00	0.21	0.21	0.0	0.4	65.3%	0.03	0.34
2035	0.00	0.21	0.21	0.0	0.5	63.3%	0.03	0.36
2036	0.00	0.21	0.21	0.0	0.5	61.4%	0.03	0.39
2037	0.00	0.21	0.21	0.0	0.6	59.6%	0.03	0.42
2038	0.00	0.21	0.21	0.0	0.6	57.8%	0.03	0.45
2039	0.00	0.21	0.21	0.0	0.7	56.1%	0.03	0.47
2040	0.00	0.21	0.21	0.0	0.7	54.4%	0.03	0.50
2041	0.00	0.21	0.21	0.0	0.8	52.7%	0.02	0.52
2042	0.00	0.21	0.21	0.0	0.8	51.2%	0.02	0.55
2043	0.00	0.21	0.21	0.0	0.9	49.6%	0.02	0.57
2044	0.00	0.21	0.21	0.0	0.9	48.1%	0.02	0.59
2045	0.00	0.21	0.21	0.0	0.9	46.7%	0.02	0.61
2046	0.00	0.21	0.21	0.0	1.0	45.3%	0.02	0.63
2047	0.00	0.21	0.21	0.0	1.0	43.9%	0.02	0.65
2048	0.00	0.21	0.21	0.0	1.1	42.6%	0.02	0.67
2049	0.00	0.21	0.21	0.0	1.1	41.3%	0.02	0.69
2050	0.00	0.21	0.21	0.0	1.2	40.1%	0.02	0.71
2051	0.00	0.21	0.21	0.0	1.2	38.9%	0.02	0.73
2052	0.00	0.21	0.21	0.0	1.3	37.7%	0.02	0.75
2053	0.00	0.21	0.21	0.0	1.3	36.6%	0.02	0.76
2054	0.00	0.21	0.21	0.0	1.4	35.5%	0.02	0.78
2055	0.00	0.21	0.21	0.0	1.4	34.4%	0.02	0.80
2056	0.00	0.21	0.21	0.0	1.5	33.4%	0.02	0.81
2057	0.00	0.21	0.21	0.0	1.5	32.4%	0.01	0.83
2058	0.00	0.21	0.21	0.0	1.5	31.4%	0.01	0.84
2059	0.00	0.21	0.21	0.0	1.6	30.5%	0.01	0.86
2060	0.00	0.21	0.21	0.0	1.6	29.6%	0.01	0.87
2061	0.00	0.21	0.21	0.0	1.7	28.7%	0.01	0.88
2062	0.00	0.21	0.21	0.0	1.7	27.8%	0.01	0.89
2063	0.00	0.21	0.21	0.0	1.8	27.0%	0.01	0.91
2064	0.00	0.21	0.21	0.0	1.8	26.2%	0.01	0.92
2065	0.00	0.21	0.21	0.0	1.9	25.4%	0.01	0.93
2066	0.00	0.21	0.21	0.0	1.9	24.6%	0.01	0.94
2067	0.00	0.21	0.21	0.0	2.0	23.9%	0.01	0.95
2068	0.00	0.21	0.21	0.0	2.0	23.2%	0.01	0.96
2069	0.00	0.21	0.21	0.0	2.1	22.5%	0.01	0.97
2070	0.00	0.21	0.21	0.0	2.1	21.8%	0.01	0.98
2071	0.00	0.21	0.21	0.0	2.1	21.2%	0.01	0.99
2072	0.00	0.21	0.21	0.0	2.2	20.5%	0.01	1.00
2073	0.00	0.21	0.21	0.0	2.2	19.9%	0.01	1.01
2074	0.00	0.21	0.21	0.0	2.3	19.3%	0.01	1.02
2075	0.00	0.21	0.21	0.0	2.3	18.7%	0.01	1.03
2076	0.00	0.21	0.21	0.0	2.4	18.2%	0.01	1.04
2077	0.00	0.21	0.21	0.0	2.4	17.6%	0.01	1.05
2078	0.00	0.21	0.21	0.0	2.5	17.1%	0.01	1.06
2079	0.00	0.21	0.21	0.0	2.5	16.6%	0.01	1.06
2080	0.00	0.21	0.21	0.0	2.6	16.1%	0.01	1.07
2081	0.00	0.21	0.21	0.0	2.6	15.6%	0.01	1.08
2082	0.00	0.21	0.21	0.0	2.7	15.1%	0.01	1.08
2083	0.00	0.21	0.21	0.0	2.7	14.7%	0.01	1.09
2084	0.00	0.21	0.21	0.0	2.7	14.2%	0.01	1.10
2085	0.00	0.21	0.21	0.0	2.8	13.8%	0.01	1.10
2086	0.00	0.21	0.21	0.0	2.8	13.4%	0.01	1.11
2087	0.00	0.21	0.21	0.0	2.9	13.0%	0.01	1.12
2088	0.00	0.21	0.21	0.0	2.9	12.6%	0.01	1.12
2089	0.00	0.21	0.21	0.0	3.0	12.2%	0.01	1.13
2090	0.00	0.21	0.21	0.0	3.0	11.9%	0.01	1.13
2091	0.00	0.21	0.21	0.0	3.1	11.5%	0.01	1.14

Year	Habitat Value Before	Habitat Value After	Habitat Lift	Service Acre Year Increment Gain	Service Acre Year Cumulative Gain	Discount Adjustment	DSAY Increment	DSAYs Cumulative
2092	0.00	0.21	0.21	0.0	3.1	11.2%	0.01	1.14
2093	0.00	0.21	0.21	0.0	3.2	10.8%	0.00	1.15
2094	0.00	0.21	0.21	0.0	3.2	10.5%	0.00	1.15
2095	0.00	0.21	0.21	0.0	3.3	10.2%	0.00	1.16
2096	0.00	0.21	0.21	0.0	3.3	9.9%	0.00	1.16
2097	0.00	0.21	0.21	0.0	3.3	9.6%	0.00	1.17
2098	0.00	0.21	0.21	0.0	3.4	9.3%	0.00	1.17
2099	0.00	0.21	0.21	0.0	3.4	9.0%	0.00	1.18
2100	0.00	0.21	0.21	0.0	3.5	8.7%	0.00	1.18
2101	0.00	0.21	0.21	0.0	3.5	8.5%	0.00	1.18
2102	0.00	0.21	0.21	0.0	3.6	8.2%	0.00	1.19
2103	0.00	0.21	0.21	0.0	3.6	8.0%	0.00	1.19
2104	0.00	0.21	0.21	0.0	3.7	7.7%	0.00	1.19
2105	0.00	0.21	0.21	0.0	3.7	7.5%	0.00	1.20
2106	0.00	0.21	0.21	0.0	3.8	7.3%	0.00	1.20
2107	0.00	0.21	0.21	0.0	3.8	7.1%	0.00	1.20
2108	0.00	0.21	0.21	0.0	3.9	6.9%	0.00	1.21
2109	0.00	0.21	0.21	0.0	3.9	6.6%	0.00	1.21
2110	0.00	0.21	0.21	0.0	3.9	6.4%	0.00	1.21
2111	0.00	0.21	0.21	0.0	4.0	6.3%	0.00	1.22
2112	0.00	0.21	0.21	0.0	4.0	6.1%	0.00	1.22
2113	0.00	0.21	0.21	0.0	4.1	5.9%	0.00	1.22
2114	0.00	0.21	0.21	0.0	4.1	5.7%	0.00	1.22
2115	0.00	0.21	0.21	0.0	4.2	5.5%	0.00	1.23
2116	0.00	0.21	0.21	0.0	4.2	5.4%	0.00	1.23
2117	0.00	0.21	0.21	0.0	4.3	5.2%	0.00	1.23
2118	0.00	0.21	0.21	0.0	4.3	5.1%	0.00	1.23
2119	0.00	0.21	0.21	0.0	4.4	4.9%	0.00	1.24
2120	0.00	0.21	0.21	0.0	4.4	4.8%	0.00	1.24
2121	0.00	0.21	0.21	0.0	4.5	4.6%	0.00	1.24
2122	0.00	0.21	0.21	0.0	4.5	4.5%	0.00	1.24
2123	0.00	0.21	0.21	0.0	4.5	4.3%	0.00	1.25
2124	0.00	0.21	0.21	0.0	4.6	4.2%	0.00	1.25
2125	0.00	0.21	0.21	0.0	4.6	4.1%	0.00	1.25
2126	0.00	0.21	0.21	0.0	4.7	4.0%	0.00	1.25
2127	0.00	0.21	0.21	0.0	4.7	3.8%	0.00	1.25
2128	0.00	0.21	0.21	0.0	4.8	3.7%	0.00	1.25
2129	0.00	0.21	0.21	0.0	4.8	3.6%	0.00	1.26
2130	0.00	0.21	0.21	0.0	4.9	3.5%	0.00	1.26
2131	0.00	0.21	0.21	0.0	4.9	3.4%	0.00	1.26
2132	0.00	0.21	0.21	0.0	5.0	3.3%	0.00	1.26
2133	0.00	0.21	0.21	0.0	5.0	3.2%	0.00	1.26
2134	0.00	0.21	0.21	0.0	5.1	3.1%	0.00	1.26
2135	0.00	0.21	0.21	0.0	5.1	3.0%	0.00	1.27
2136	0.00	0.21	0.21	0.0	5.1	2.9%	0.00	1.27
2137	0.00	0.21	0.21	0.0	5.2	2.8%	0.00	1.27
2138	0.00	0.21	0.21	0.0	5.2	2.7%	0.00	1.27
2139	0.00	0.21	0.21	0.0	5.3	2.7%	0.00	1.27
2140	0.00	0.21	0.21	0.0	5.3	2.6%	0.00	1.27
2141	0.00	0.21	0.21	0.0	5.4	2.5%	0.00	1.27
2142	0.00	0.21	0.21	0.0	5.4	2.4%	0.00	1.27
2143	0.00	0.21	0.21	0.0	5.5	2.4%	0.00	1.27
2144	0.00	0.21	0.21	0.0	5.5	2.3%	0.00	1.28
2145	0.00	0.21	0.21	0.0	5.6	2.2%	0.00	1.28
2146	0.00	0.21	0.21	0.0	5.6	2.2%	0.00	1.28
2147	0.00	0.21	0.21	0.0	5.7	2.1%	0.00	1.28
2148	0.00	0.21	0.21	0.0	5.7	2.0%	0.00	1.28
2149	0.00	0.21	0.21	0.0	5.7	2.0%	0.00	1.28
2150	0.00	0.21	0.21	0.0	5.8	1.9%	0.00	1.28
2151	0.00	0.21	0.21	0.0	5.8	1.8%	0.00	1.28
2152	0.00	0.21	0.21	0.0	5.9	1.8%	0.00	1.28
2153	0.00	0.21	0.21	0.0	5.9	1.7%	0.00	1.28
2154	0.00	0.21	0.21	0.0	6.0	1.7%	0.00	1.28
2155	0.00	0.21	0.21	0.0	6.0	1.6%	0.00	1.29
2156	0.00	0.21	0.21	0.0	6.1	1.6%	0.00	1.29
2157	0.00	0.21	0.21	0.0	6.1	1.5%	0.00	1.29
2158	0.00	0.21	0.21	0.0	6.2	1.5%	0.00	1.29
2159	0.00	0.21	0.21	0.0	6.2	1.4%	0.00	1.29
2160	0.00	0.21	0.21	0.0	6.3	1.4%	0.00	1.29
2161	0.00	0.21	0.21	0.0	6.3	1.4%	0.00	1.29
2162	0.00	0.21	0.21	0.0	6.3	1.3%	0.00	1.29
2163	0.00	0.21	0.21	0.0	6.4	1.3%	0.00	1.29
2164	0.00	0.21	0.21	0.0	6.4	1.2%	0.00	1.29
2165	0.00	0.21	0.21	0.0	6.5	1.2%	0.00	1.29
2166	0.00	0.21	0.21	0.0	6.5	1.2%	0.00	1.29
2167	0.00	0.21	0.21	0.0	6.6	1.1%	0.00	1.29
2168	0.00	0.21	0.21	0.0	6.6	1.1%	0.00	1.29
2169	0.00	0.21	0.21	0.0	6.7	1.1%	0.00	1.29
2170	0.00	0.21	0.21	0.0	6.7	1.0%	0.00	1.29
2171	0.00	0.21	0.21	0.0	6.8	1.0%	0.00	1.30
2172	0.00	0.21	0.21	0.0	6.8	1.0%	0.00	1.30
2173	0.00	0.21	0.21	0.0	6.9	0.9%	0.00	1.30
2174	0.00	0.21	0.21	0.0	6.9	0.9%	0.00	1.30
2175	0.00	0.21	0.21	0.0	6.9	0.9%	0.00	1.30
2176	0.00	0.21	0.21	0.0	7.0	0.9%	0.00	1.30
2177	0.00	0.21	0.21	0.0	7.0	0.8%	0.00	1.30
2178	0.00	0.21	0.21	0.0	7.1	0.8%	0.00	1.30
2179	0.00	0.21	0.21	0.0	7.1	0.8%	0.00	1.30
2180	0.00	0.21	0.21	0.0	7.2	0.8%	0.00	1.30
2181	0.00	0.21	0.21	0.0	7.2	0.7%	0.00	1.30
2182	0.00	0.21	0.21	0.0	7.3	0.7%	0.00	1.30
2183	0.00	0.21	0.21	0.0	7.3	0.7%	0.00	1.30
2184	0.00	0.21	0.21	0.0	7.4	0.7%	0.00	1.30
2185	0.00	0.21	0.21	0.0	7.4	0.7%	0.00	1.30
2186	0.00	0.21	0.21	0.0	7.5	0.6%	0.00	1.30
2187	0.00	0.21	0.21	0.0	7.5	0.6%	0.00	1.30
2188	0.00	0.21	0.21	0.0	7.5	0.6%	0.00	1.30
2189	0.00	0.21	0.21	0.0	7.6	0.6%	0.00	1.30
2190	0.00	0.21	0.21	0.0	7.6	0.6%	0.00	1.30
2191	0.00	0.21	0.21	0.0	7.7	0.5%	0.00	1.30
2192	0.00	0.21	0.21	0.0	7.7	0.5%	0.00	1.30
2193	0.00	0.21	0.21	0.0	7.8	0.5%	0.00	1.30
2194	0.00	0.21	0.21	0.0	7.8	0.5%	0.00	1.30
2195	0.00	0.21	0.21	0.0	7.9	0.5%	0.00	1.30

Year	Habitat Value Before	Habitat Value After	Habitat Lift	Service Acre Year Increment Gain	Service Acre Year Cumulative Gain	Discount Adjustment	DSAY Increment	DSAYs Cumulative
2300	0.00	0.21	0.21	0.0	12.7	0.0%	0.00	1.31
2301	0.00	0.21	0.21	0.0	12.8	0.0%	0.00	1.31
2302	0.00	0.21	0.21	0.0	12.8	0.0%	0.00	1.31
2303	0.00	0.21	0.21	0.0	12.9	0.0%	0.00	1.31
2304	0.00	0.21	0.21	0.0	12.9	0.0%	0.00	1.31
2305	0.00	0.21	0.21	0.0	13.0	0.0%	0.00	1.31
2306	0.00	0.21	0.21	0.0	13.0	0.0%	0.00	1.31
2307	0.00	0.21	0.21	0.0	13.0	0.0%	0.00	1.31
2308	0.00	0.21	0.21	0.0	13.1	0.0%	0.00	1.31
2309	0.00	0.21	0.21	0.0	13.1	0.0%	0.00	1.31
2310	0.00	0.21	0.21	0.0	13.2	0.0%	0.00	1.31
2311	0.00	0.21	0.21	0.0	13.2	0.0%	0.00	1.31
2312	0.00	0.21	0.21	0.0	13.3	0.0%	0.00	1.31
2313	0.00	0.21	0.21	0.0	13.3	0.0%	0.00	1.31
2314	0.00	0.21	0.21	0.0	13.4	0.0%	0.00	1.31
2315	0.00	0.21	0.21	0.0	13.4	0.0%	0.00	1.31
2316	0.00	0.21	0.21	0.0	13.5	0.0%	0.00	1.31
2317	0.00	0.21	0.21	0.0	13.5	0.0%	0.00	1.31
2318	0.00	0.21	0.21	0.0	13.6	0.0%	0.00	1.31
2319	0.00	0.21	0.21	0.0	13.6	0.0%	0.00	1.31

Reference

To return to the previous worksheet and location press F5 + Enter keys simultaneously.

Table 1: Scenarios for Lower Shore Zone: Submerged Aquatic Vegetation (SAV) within 25 feet of Project Area

VEGETATION SCENARIO	Native Eelgrass and/or Kelp	Other SAV (no native eelgrass or kelp present)
Scenario 0	N/A	≤ 10%
Scenario 1	1-25% Combined SAV	11-25%
Scenario 2	26-69% Combined SAV	26-75%
Scenario 3	≥ 70% Combined SAV	> 75%

*SAV is defined as rooted vascular plants and attached macroalgae. Drift algae and *Ulva spp.* are not included when determining cover percentage except where *Ulva spp.* occurs in documented herring spawning areas.

EXAMPLE: A site in the LSZ has 25% native eelgrass and 45% other SAV (combined SAV total 70%) within 25 feet of project area. This would be Scenario 3 because native eelgrass is present within 25 feet of the project area.

Table 2: Scenarios for Upper Shore Zone: Upper Intertidal Vegetation within 25 feet of Project Area

VEGETATION SCENARIO	Macro algae and saltmarsh vegetation like <i>Salicornia sp.</i> and <i>Distichlis sp.</i>
Scenario 0	Less than 5% of cover
Scenario 1	Between >5% and < 30% of cover
Scenario 2	Between >30% and <60% of cover
Scenario 3	Over 60% of cover

Table 3: Delineation of Shore Zones

NEARSHORE ZONE	Description
Riparian Zone	HAT to 130 feet landward of HAT
Upper Shore Zone (USZ)	HAT to +5 feet MLLW
Lower Shore Zone (LSZ)	+5 feet MLLW to -10 feet MLLW and limits of SAV
Deeper Shore Zone (DSZ)	Deeper than -10 feet MLLW or outer limits of SAV

Nearshore Zones

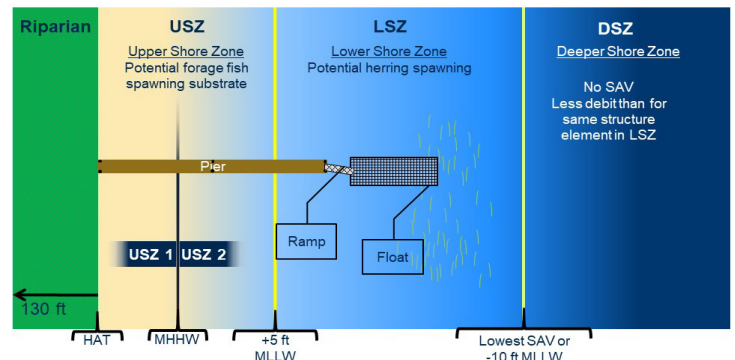

Figure by Lee Corum, USFWS

Examples of Complex Floats and Calculator Entry

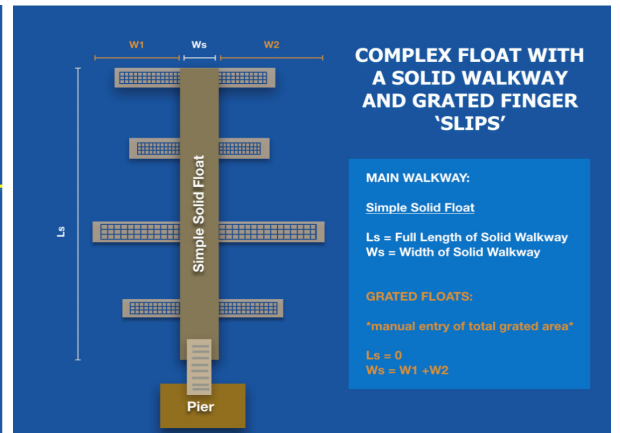
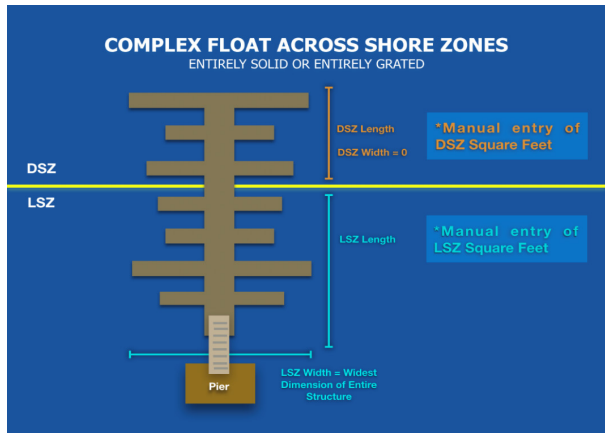
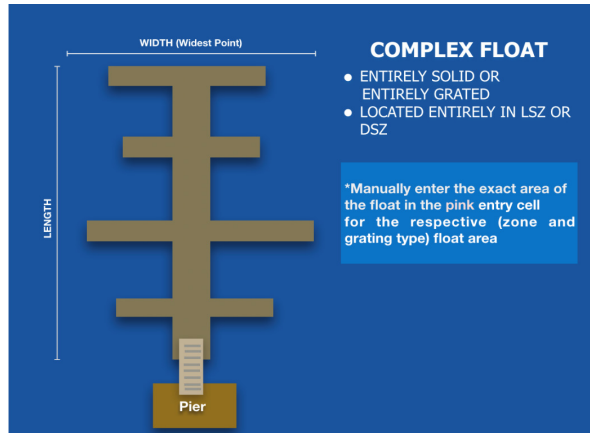

Figure 2: Application of Credit Factors

Not all credit factors are applied for all structures or all shore zones. See the table below for applicability of each. Credit factors apply to the entire elevation polygon, they do not reflect a before after change. They are a function of inherent site conditions.

Credit factors for water quality benefits related to creosote removal are 40% of full credit factors because we expect creosote piles to be on site for approximately 40 years of the 100 year assumed benefit period.

Nearshore Impact	Major Estuary Zone	Pocket Beach	Feeder Bluff	Sand lance or surf smelt spawning	Updrift of FF spawning within same drift cell	Herring spawning
Shoreline armoring	XX	XX	XX	XX	XX	In rare cases
Piers and ramps	XX	XX				
Piles depending on zone	XX	XX	XX	XX		XX
Floats (USZ)	XX	XX		XX	In rare cases	
Floats (LSZ)	XX	XX				XX
Floats (DZ)	XX	XX				depends
Creosote Piles WQ benefit	X	X		X		X
Boat ramps & Jetties (USZ)	XX	XX	XX	XX	In rare cases	
Boat ramps & Jetties (LSZ)	XX	XX				XX
Boat ramps & Jetties (DZ)	XX	XX				
Beach Nourishment	XX	XX		XX	XX	
Riparian	XX	XX	XX	XX		

Explanation of Pocket Estuaries and Embayment's

While the GIS layer for "Major Estuary Zones" and "Pocket Estuary or Embayment" is depicted as a band (this is an artifact of how the GIS layer was created), these landscape-scale credit/debit factors apply to all zones and the entire structure. In other words, if any part of a structure is at a location that is mapped as either "Major Estuary Zones" and/or "Pocket Estuary or Embayment", this credit factor applies to all parts of that structure not just the parts that are located on the band shown on the GIS layer; also see Figure 2.

[The online GIS layer to determine Natal and Pocket Estuaries](#)

Many classification systems have been created and refined to describe Puget Sound shoreline habitats (Shipman 2008, McBride 2009). Many of these systems are based on a combination of geomorphic, oceanographic, chemical, and biological characteristics (McBride 2009). When using the term 'pocket estuary' we include embayment's, estuaries, and lagoons. The Geographic Information System (GIS) layer we use to designate Puget Sound Natal and Pocket Estuaries also encompasses these geomorphic types.

Cereghino et al. (2012) proposed two classes of embayment site: coastal inlets, which are formed such that their protected shallow structures are not dependent on beach dynamics for their existence, and barrier-type, which are embedded in a beach system and are somewhat dependent on a barrier beach for wave protection and wetland development. We also drew upon Shipman (2008) who uses the term embayment to include protected estuaries and lagoons where there is little wave action to form beaches. Estuaries are those with a significant input of freshwater from a surface stream, whereas lagoons have limited freshwater input. Both are tidally influenced. Natal estuaries are often recognized as important habitats for juvenile salmonids in Puget Sound for passage to and from freshwater and/or for extended rearing (Greene et al. 2017). However, in addition, the use of nonnatal estuaries and intertidal areas along the shoreline have been shown to be important habitats for juvenile Chinook salmon during migration in the Puget Sound (Hayes et al. 2019, Beamer et al. 2013).